

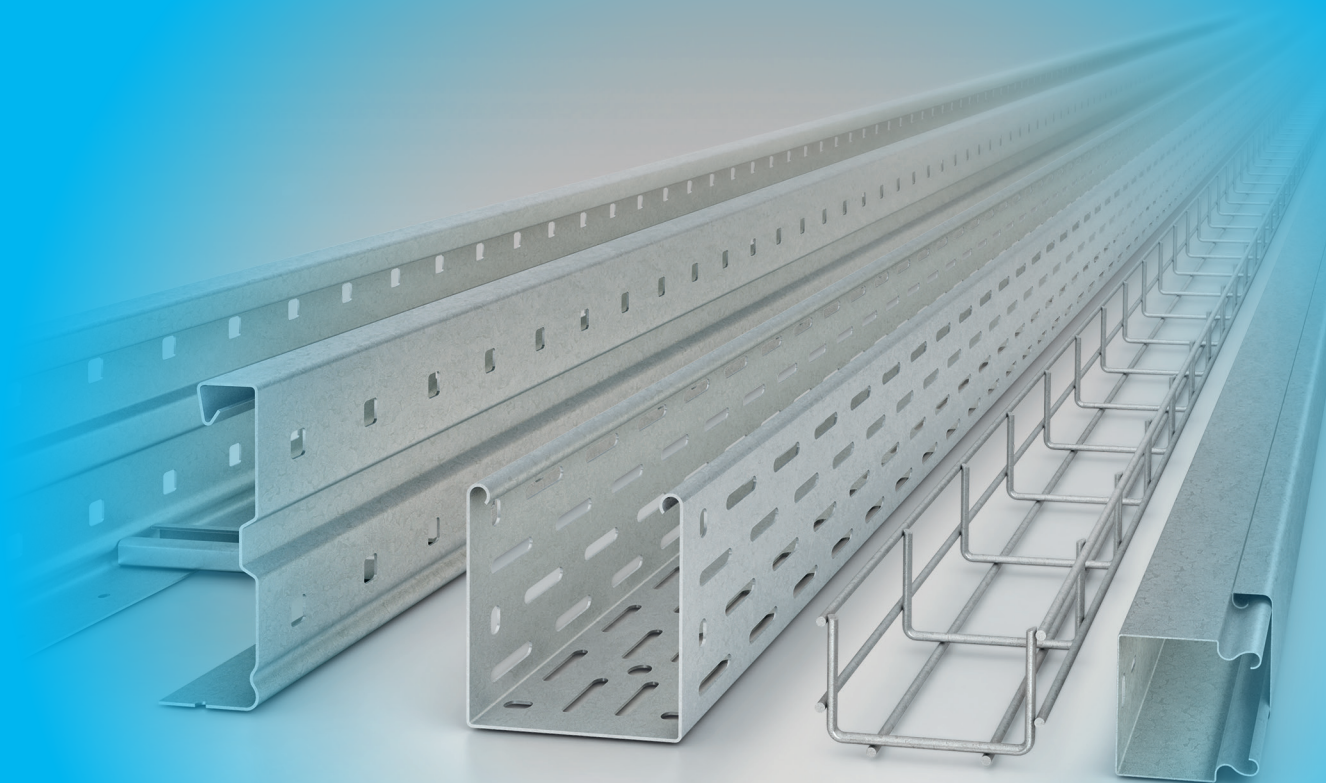















NIEDAX GROUP



CABLE TRAY
SYSTEMS

ICONS

 New	 Siderail Height in mm	 Temperature resistance	 Reference Note
 Discontinued model	 Wire Diameter in mm	 Fast Install	 Information pages
 No halogen	 Pipe Diameter in mm	 Hardware	
 No silicone	 Pipe Diameter in mm	 Installation Instructions	

Steel

B Steel, bare
V Steel, galvanized according to DIN EN ISO 50 961/50979 and DIN EN ISO 2081, blued, (Replacement galvanized according to DIN EN ISO 4042)
VC Steel, galvanized according to nach DIN 50961/50979 und DIN EN ISO 2081, blued and powdercoated
G Steel, galvanized according to DIN EN ISO 50 961/50979 and DIN EN ISO 2081, passivated, (Replacement galvanized according to DIN EN ISO 4042)
S Steel, pre-galvanized according to DIN EN 10346
F Steel, hot dip galvanized after fabrication (HDGAF) according to DIN EN ISO 1461 (Replacement according to DIN EN ISO 50 976)
FD Steel, hot dip galvanized after fabrication (HDGAF), double dip method
SB Steel, black-oxide finish
FG Steel, geomet® galvanized
DV Steel, wire galvanized according to DIN EN 10244
C COLOR Steel, pre-galvanized and powdercoated

Stainless Steel

E1 Material Code.: 1.4016	E4 Material Code.: 1.4401, 1.4404	E7 Material Code.: 1.4547	E10 Material Code.: 1.4307
E2 Material Code.: 1.4310	E5 Material Code.: 1.4571	E8 Material Code.: 1.4430	E11 Material Code.: 1.4034
E3 Material Code.: 1.4301, 1.4303	E6 Material Code.: 1.4529	E9 Material Code.: 1.4362	

AL Aluminium, N = naturally anodized, P = mill-finished, C = powdercoated in RAL colours

P Electrotechnical Porcelain, non halogen **MS** Brass **CU** Copper

Plastics/Elastomer

K01 PA - Polyamide, non halogen	K14 POM - Polyacetal
K02 PS - Polystyrene, non halogen, impact resistant	K15 SBR - Styrene-Butadiene Rubber
K03 PE - Polyethylene, non halogen	K16 CR/NBR - Chloroprene/Nitrile Rubber, halogenated
K04 PP - Polypropylene, non halogen	K17 CR/SBR - Chloroprene/Styrene-Butadiene Rubber, halogenated
K05 PC - Polycarbonate, non halogen	K18 TPE - Thermoplastic Elastomer
K06 SBR/NBR - Styrene-Butadiene-Nitrile Rubber	K19 FS 31 - Phenolic Resin
K07 CR - Chloroprene Rubber, halogenated	K20 SI - Silicone Rubber
K08 NBR - Nitrile Rubber	K21 PUR - Polyurethane
K09 PVC hard - Hard Polyvinylchloride, halogenated	K22 PET - Polyethylene Terephthalate, non halogen
K10 PVC - Polyvinylchloridide, halogenated	K23 UP-GF - Glass-Fiber Reinforced Polyester, non halogen
K11 ABS - Acrylnitrile-Butadiene-Styrene, non halogen	C1 Epoxy Coating, non halogen
K12 ASA - Acrylate-Styrol-Acrylnitrile Copolymer	

 <p>CLASSIFIED UL US</p> <p>9JA9 E 233344</p>	<p>Cable Tray System Products are classified by UL in accordance to NEMA VE1-2009 for USA and CAN/CSA - C22.2 No. 126.1-98 for Canada</p>	 <p>UL US LISTED</p> <p>7YA6 E 230529</p>	<p>Surface Metal Raceway System Products are listed by UL in accordance to UL 5 for USA and CAN/CSA - C22.2 No. 62-93 for Canada</p>
---	---	--	--

Important notice: The information herein has been carefully checked for accuracy and is believed to be correct and current. No warranty, either expressed or implied, is made as to either its applicability to or its compatability with specific requirements of this information, nor for damages consequential to its use. All design characteristics, specifications, tolerances and similar information are subject to change without notice.

Alphabetical table of contents
Type listing

Page 2-4

Page 6-20

General Information

- Material Handling
- Finishes
- Corrosion Protection
- Installation Instructions



Support System

- Hangers
- Brackets
- Profiles
- Head Plates

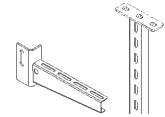

Wire Mesh Tray System

- Wire Mesh Trays
- Barrier Strips
- Covers
- Accessories

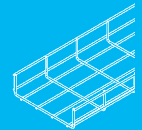

Cable Tray System

- Cable Trays
- Fittings
- Barrier Strips
- Covers
- Accessories

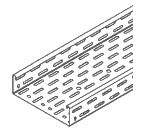

Walkable Cable Tray System

- Cable Trays
- Fittings
- Barrier Strips
- Covers
- Accessories

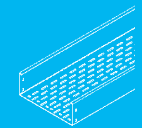

Cable Ladder System

- Cable Ladders
- Fittings
- Covers
- Accessories

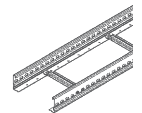

Vertical Cable Ladder System

- Vertical Cable Ladder
- Accessories



Marine Cable Ladder System

- Cable Ladders
- Rungs
- Splice Plates

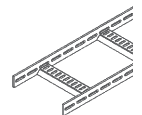

Long Span System

- Long Span Cable Trays
- Long Span Cable Ladders
- Fittings
- Accessories

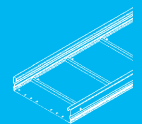

Channel Cable Tray

- Channel Cable Tray
- Fittings
- Accessories

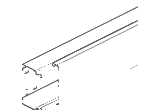

TABLE OF CONTENTS IN ALPHABETICAL ORDER

2	
2970 Framing Channel	120
2986 Framing Channel	120
2991 Framing Channel	121
2996Z Toothed Framing Channel	122
A	
Adjustable Corner Bracket	129
Adjustable Horizontal Splice/Reducer/Blind End	183, 195, 209, 226, 229
Adjustable Splice Plate	154, 246-247, 279, 283-284, 291-292, 296-297
Adjustable Vertical Elbow	250
Adjustable Vertical Splice Plate	183, 195, 209
Adjustable Wall Bracket	80
Aluminum Checker Plate Cover for 45° Horizontal Elbow	231
Aluminum Checker Plate Cover for 90° Horizontal Elbow	231
Aluminum Checker Plate Cover for Horizontal Extension Tee	232
Aluminum Checker Plate Cover for Horizontal Tee	233
B	
Barrier Strip	155, 179, 192, 205, 247, 279, 284, 292, 297, 311
Beam Clamp	82, 87, 125
Bendable Multifunction Splice Bar	153
Bolt Anchor	134, 238
Boltless splice plate	153, 176, 190
Bottom Connection Plate	286
Box/Wall Connector	88
Bracket	79-80, 84, 96, 103, 109, 116-117
Bracket for HUF Profiles and Square Tubes	96
C	
Cable Drop Out	155
Cable Ladder	246
Cable Ladder Connection Bracket	250
Cable Ladder Mounting Bracket	251
Cable Retainer Clamp	316
Cable Tray	175, 177, 189, 201
C-Bracket for Mesh Tray	160
C-Clamp with Locknut	130
Center Hanger/Trapeze Support	79
Center Hanger/Trapeze Support for Wire Mesh Basket	160
Channel Nut	122-123
Cito Line Wire Mesh Tray	146-147
Clamping Adapter	81-82, 85-86
Clamping Bracket	87
Clamping Head Plate	94-95, 102-103, 108-109, 115-116
Column Support for 2986 and 2996 Channel	129
Combination Bracket/Hanger	76
Counter Pressure Cradle for all Yoke-Clamps	138
Cover	152, 212
Cover Clamp	218
C	
Cover Clamps for GTD Wire Mesh Covers	148
Cover for 90° Horizontal Elbow	170, 214, 301
Cover for 90° Horizontal Elbow (small radius)	252
Cover for Cable Tray/Ladder	212, 252
Cover for Distribution Cable Tray	169
Cover for Flexible Horizontal Fitting	213
Cover for Horizontal Cross	215
Cover for Horizontal Extension Tee	170, 213, 302
Cover for Horizontal Tee	171, 214, 252, 302
Cover for Long Span Cable Trays/Ladders	301
Cover for Mini Cable Tray	167
Cover for MTC Wire Mesh Tray	148
Cover for Vertical Inside Elbow	216
Cover for Vertical Outside Elbow Kit	215-216
D	
Distribution Cable Tray	168, 176, 190, 203
Divider	224, 227
E	
Edge Protection	287
Edge Protection Plate	185, 197, 211, 286
Edge Protection Ring	134-135, 169, 176, 190, 203
Edge Protection Strip	134
Elbow 45°	225, 312
Elbow 90°	225, 314
Elbow Splice Bar	154
Elbow Splice Clip	153
Enclosure Panel Kit for Vertical Ladder	262-263
End Plate with Cover Lock	226, 229
End-Cap	309, 316
Endplate	281, 286, 299
End-Protection Ring	309, 316
Extension Horizontal Tee	170, 181, 193, 206, 228, 249, 270, 280, 285, 293, 298
Extension Tee	225
Exterior Cover Clamp	217
F	
Five Hole Tee Gusset Plate	128
Flange Clamp	130
Flexible Divider	224, 227
Flexible Horizontal Elbow 0-90°	181, 194, 207
Floor Mounting Bracket (height: 100 mm)	235
Floor Mounting Bracket (height: 110 mm)	235
Floor Mounting Bracket (height: 50 mm)	234
Floor Mounting Bracket (height: 80 mm)	234
Floor Stand	161, 236-237
Floor Stand (height: 85 mm)	235
Four Hole Corner Gusset Plate	128
G	
Gripping Channel Nut	83, 123
H	
Hammerset Flange Clamp	130
Hanger for Wire Mesh Tray	159
Hanger/Wall Bracket for Wire Mesh Tray	159

H	
Head Plate	93-94, 102, 108, 114-115, 261
Head Plate Extender Device	114
Heavy Duty Aluminium Checker Plate Cover	230
Heavy Duty Antiskid Cover (DIN 51130 class R10)	230
Heavy Duty Antiskid Cover for 45° Horizontal Elbow	230
Heavy Duty Antiskid Cover for 90° Horizontal Elbow	231
Heavy Duty Antiskid Cover for Horizontal Extension Tee	232
Heavy Duty Cable Tray	178, 191, 202, 224, 226
Heavy Duty Cover	229
Heavy Duty Cover Clamp	234, 263
Heavy Duty Cover for 45° Horizontal Elbow	230
Heavy Duty Cover for 90° Horizontal Elbow	231
Heavy Duty Cover for Horizontal Extension Tee	232
Heavy Duty Cover for Horizontal Tee	232
Heavy Duty I-Beam Clamping Assembly	127
Heavy Duty Square Washer/Anchor Plate	129
Heavy Duty Turnbolt Lock	233
Hexagonal Bolt	83, 87, 131
Hexagonal Nut	133
Hexagonal Rod Coupling	133
Hook Head Bolt, size M10	83, 124
Hook Head Bolt, size M12	124-125
Horizontal Cross	183, 195, 208, 249
Horizontal Elbow 45°	182, 194, 207, 227, 270
Horizontal Elbow 90°	170, 182, 194, 207, 228, 270, 280, 285, 293, 298
Horizontal Elbow 90° (large radius)	248
Horizontal Elbow 90° (small radius)	248
Horizontal Elbow Building Block	181, 193, 206, 280, 284, 292, 297
Horizontal Tee	170, 182, 194, 208, 225, 228, 249, 281, 285, 294, 299, 315
I	
I-Beam Clamping Assembly	126
Inside Elbow 45°	312
Inside Elbow 90°	313
Inside Strut Joiner	122
J	
J-Hook Bolt	154
L	
Ladder Drop Out	250, 300
Large Diameter Washer	133
Large Square Splice Washer/Clamping Bracket	154
Long Span Cable Ladder	291, 295-296
Long Span Cable Tray	278, 282-283
M	
Marine Cable Ladder	269

M	
Mini Cable Tray	167
Mini Metal Raceway	309
Mounting Clamp for Barrier Strip	155, 247, 280, 284, 292, 297
Mounting Clamp for Long Span Ladders	300
Mounting Kit for Enclosure Panel	263
Mounting Plate for Barrier Strip	180, 192, 205, 311
Mounting Plate for Barrier Strip with M6 Stud	180, 193, 206
Mushroom Head Bolt	131-132, 154, 237, 270
N	
Nail Anchor	134, 238
O	
Outside Elbow 45°	312
Outside Elbow 90°	313
Outside Wide Radius Elbow (2x45°)	313
Overhead Hanger	92, 100, 106, 112
Overhead Hanger and Wall Bracket	76
P	
Pair of Protective End Caps	250, 294
Pedestal Clamp	161
Profile I 80	113, 262
Profile U 50	93
Profile U 5050	101
Profile U 6040	107, 259
Protective End Cap	78, 80, 92, 100, 106, 112, 116, 121-122
Punch and Die Set for hydraulic tools	135
R	
Reducer	281, 286, 299
Reducer/Blind End	183, 195, 208, 226, 228
Retaining bracket	152
Rounded Head Torx Bolt	237
Rungs for Vertical Cable Ladders	258, 260
S	
Self-Tapping Screw	237
Serrated Washer	133
Shelf Bracket	129
Skirting Panel	235-236
Sloped Sliding Nut	120
Spacer	77, 95
Spacer for Overhead Hanger	101, 108
Splice Plate	204, 246, 269, 279, 283, 291, 296, 309, 311
Splice Plate for Barrier Strip	155, 180, 192, 205, 247, 279, 284, 292, 297
Splice/Link Kit	184, 196, 209
Square Splice Washer	153
Straight Splice Plate	93, 101, 107, 113, 258, 261
Surface Metal Raceway	310-311
T	
Tee Connector	113

TABLE OF CONTENTS IN ALPHABETICAL ORDER

T

Threaded Rod, size M10	132
Threaded Rod, size M12	133
Threaded Rod, size M6	132
Threaded Rod, size M8	132
Three Hole Corner Angle	128, 251, 300
Three Piece Splice Plate Kit	204
Trapeze Hanger for Wire Mesh Tray	159
Trapeze Rungs	269
Turnbolt Lock	169, 217, 233, 253, 302
Two Hole Corner Angle	127-128, 251, 259, 300
Two Hole Corner Angle for I 80	114, 261

U

Universal Splice Bolt	153
Universal Splice Plate	153, 169, 179, 191, 205, 224, 227
Universal Wire Mesh Mounting Bracket	156
U-shaped Splice Plate	179, 192, 204
U-Shaped Square Washer	154, 238

V

Vertical Cable Ladder	258, 260
Vertical Inside Elbow 45°	209
Vertical Inside Elbow 90°	184, 196, 210
Vertical Outside Elbow 45°	210
Vertical Outside Elbow 90°	184, 196, 210
Vertical Tee Down, crosswise	185, 197, 211
Vertical Tee Down, lengthwise	185, 197, 211

W

Wall and Box Mount Bracket	158
Wall and Box Mount Bracket for MTC Wire Mesh Tray	157
Wall Bracket	84
Wall/Ceiling Bracket	78
Wall/Ceiling Bracket for Wire Mesh Tray	160
Wide Radius Elbow (2x45°)	314
Wide Radius Tee	315
Wire Mesh Center Hanger	157
Wire Mesh Mounting Bracket	156
Wire Mesh Tray	149-151

Y

Yoke Clamp for Angle Sections	138
Yoke-Clamp	136-137

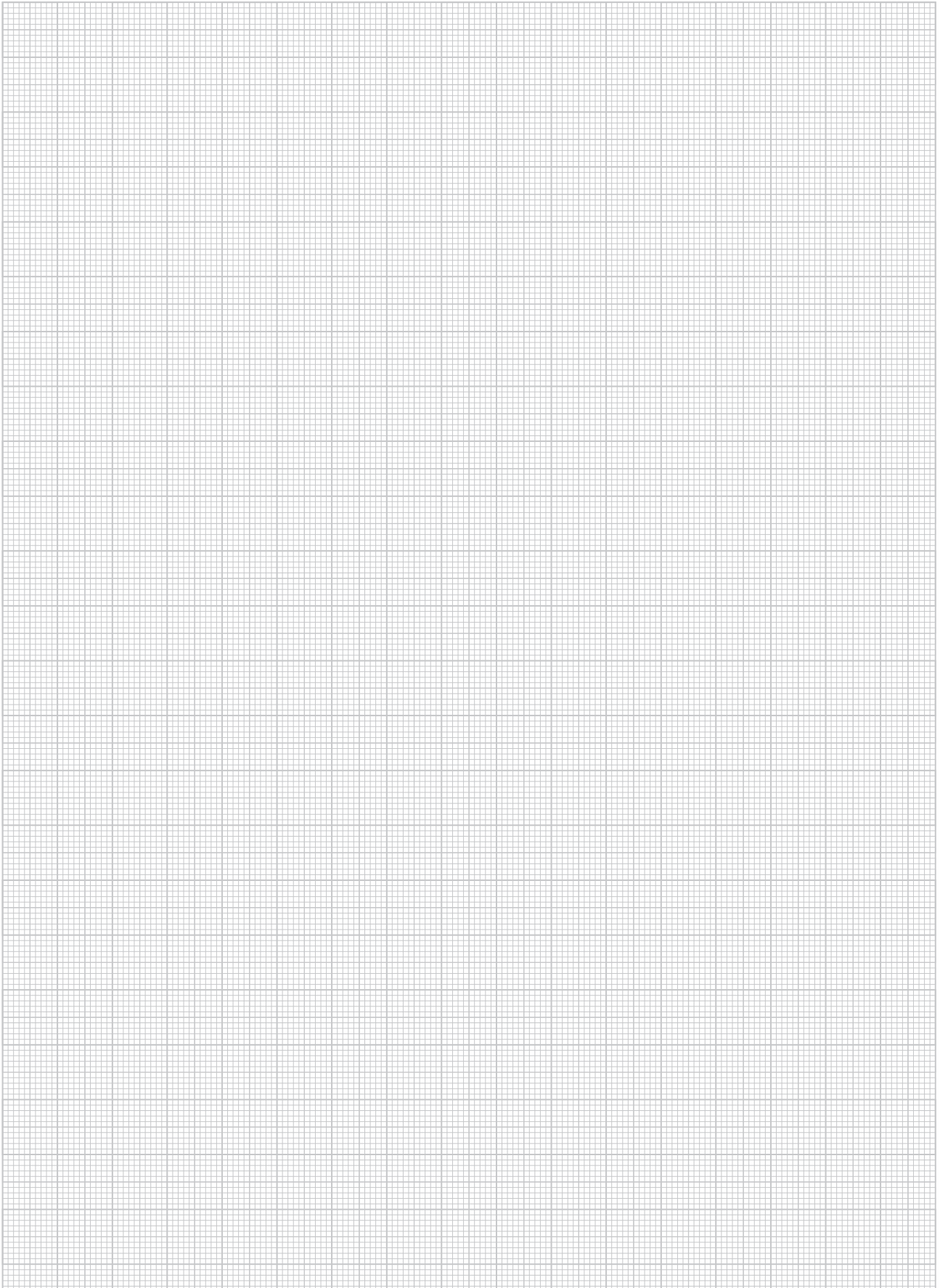

NOTES

A large rectangular area filled with a fine grid of light gray lines, intended for taking notes. The grid consists of small squares, with a slightly larger square grid pattern overlaid on top.

LIST OF ITEMS

model no.	EAN code	page	model no.	EAN code	page	model no.	EAN code	page
2970/2 GL	030101	120	BK 46	085200	137	FLM 6X12	206209	237
2970/2 SL	030309	120	BK 50	085309	137	FLM 6X12 E3	343805	131
2986/200 SL	894703	120	BK 54	085408	137	FLM 6X12 F	206407	131
2986/3 E3L	342228	120	BK 58	085507	137	FLM 6X16 F	206506	131
2986/3 FL	193165	120	BK 64	085606	137	FLM 6X20 E4	101825	154
2986/3 SL	193158	120	BL 20.65	872121	135	FLM 6X20 FG	057931	154
2986/300 SL	894727	120	BL 30.65	872145	135	FLM 6X20 G	057948	154
2986/400 SL	894741	120	BU 12	064601	137	FLM 6X20 G	057948	237
2986/500 SL	894765	120	BU 14	064700	137	FLM 8X13 F	206605	131
2986/600 SL	894772	120	BU 16	064908	137	FLM 8X16 E3	343843	131
2986/700 SL	899678	120	BU 18	065004	137	FLM 8X16 F	206704	131
2991/200 FL	193400	121	BU 22	065103	137	FLM 8X25 F	206803	131
2991/3 FL	193202	121	BU 26	065202	137	FLM 8X25 F	206803	270
2991/300 FL	193806	121	BU 30	065301	137	GMZ M10 F	947423	122
2991/400 FL	193707	121	BU 34	065400	137	GMZ M12 F	947430	123
2991/500 FL	193905	121	BU 38	065509	137	GMZ M6 F	947409	122
2991/600 FL	194001	121	BU 42	065608	137	GMZ M8 F	947416	122
2991/700 FL	194100	121	BU 46	065707	137	GMZF M10-18 E5	066414	123
2996Z/3 E3L	078639	122	BU 50	065806	137	GMZF M10-18 F	055661	83
2996Z/3 FL	960675	122	BU 54	065905	137	GMZF M10-18 F	055661	123
2996Z/6 E3L	078653	122	BU 58	066001	137	GMZF M10-22 E5	066421	123
2996Z/6 FL	960699	122	BU 64	066100	137	GMZF M10-22 F	055517	123
AWG 110/140	891801	129	BUK 14	096008	137	GMZF M12-18 E5	069828	123
AWG 110/140 E3	892167	129	BUK 18	096107	137	GMZF M12-18 F	055678	123
B 12	047406	136	BUK 22	096206	137	GMZF M12-22 E5	069835	123
B 14	047505	136	BUK 26	096305	137	GMZF M12-22 F	055524	123
B 16	047604	136	BUK 30	096404	137	GMZF M6-18 E5	069842	123
B 18	047703	136	BUK 34	096503	137	GMZF M6-18 F	055647	123
B 22	047802	136	BUK 38	096602	137	GMZF M6-22 E5	069859	123
B 26	047901	136	BUK 42	096701	137	GMZF M6-22 F	055487	123
B 30	048007	136	BUK 46	096800	137	GMZF M8-18 E5	069866	123
B 34	048106	136	BUK 50	096909	137	GMZF M8-18 F	055654	123
B 38	048205	136	BUK 54	097005	137	GMZF M8-22 E5	069873	123
B 4.2X13-TX V	132614	237	BUK 58	097104	137	GMZF M8-22 F	055494	123
B 42	048304	136	BUK 64	097203	137	GR 60.060 E3	968442	149
B 46	048403	136	BWK 14	090204	138	GR 60.100 E3	343720	149
B 50	048502	136	BWK 18	090303	138	GR 60.150 E3	343737	149
B 54	048601	136	BWK 22	090402	138	GR 60.200 E3	343744	149
B 58	048700	136	BWK 26	090501	138	GR 60.300 E3	343768	149
B 64	048809	136	BWK 30	090600	138	GRBP 6 E3	936960	156
BA 12	051700	136	BWK 34	090709	138	GRBP 6 F	966257	156
BA 14	051809	136	BWK 38	090808	138	GRBP 6 S	936953	156
BA 16	051908	136	BWK 42	090907	138	GRBS 42.100 V	148851	161
BA 18	052004	136	BWK 46	091003	138	GRBS 42.100 V	148851	237
BA 22	052103	136	BWK 50	091102	138	GRBS 42.200 V	148868	161
BA 26	052202	136	BWK 54	091201	138	GRBS 42.200 V	148868	237
BA 30	052301	136	BWK 58	091300	138	GRBS 42.300 V	148875	161
BA 34	052400	136	BWK 64	091409	138	GRBS 42.300 V	148875	237
BA 38	052509	136	DAM 6X10	117666	134	GRBS 42.400 V	148882	161
BA 42	052608	136	DAM 6X10	117666	238	GRBS 42.400 V	148882	237
BA 46	052707	136	DAM 6X5	158126	134	GRBS 42.500 V	148899	161
BA 50	052806	136	DAM 6X5	158126	238	GRBS 42.500 V	148899	237
BA 54	052905	136	DAZ 10X10	842827	134	GRBS 42.600 V	148912	161
BA 58	053001	136	DAZ 10X10	842827	238	GRBS 42.600 V	148912	237
BA 64	053100	136	DAZ 10X30	842841	134	GRBS 85.100 V	148929	237
BAK 14	087303	136	DAZ 12X10	842865	134	GRBS 85.200 V	148936	237
BAK 18	087402	136	DAZ 16X25	842889	134	GRBS 85.300 V	148943	237
BAK 22	087501	136	DAZ 8X10	842803	134	GRBS 85.400 V	148950	237
BAK 26	087600	136	DAZ 8X10	842803	238	GRBS 85.500 V	148967	237
BAK 30	087709	136	DBSK 30.30/195-1.5 S	148981	161	GRBS 85.600 V	148974	237
BAK 34	087808	136	FC-10T	745081	130	GRDHL 30 S	126996	152
BAK 38	087907	136	FC-11	745005	130	GRGV 50	940561	154
BAK 42	088003	136	FC-12T	745104	130	GRGV 50 E3	940578	154
BAK 46	088102	136	FC-13	745029	130	GRGV 50 F	940585	154
BAK 50	088201	136	FC-6T	745043	130	GRHKM 6X15 E3	012428	153
BAK 54	088300	136	FC-7	744961	130	GRHKM 6X15 F	012435	153
BAK 58	088409	136	FC-8T	745067	130	GRHKM 6X15 V	012442	153
BAK 64	088508	136	FC-9	744985	130	GRKB 10	280704	157
BK 14	084401	137	FLDM 6X30	945658	132	GRKB 10 F	280759	157
BK 18	084500	137	FLDM 6X45	207060	132	GRMB 50	864904	158
BK 22	084609	137	FLDM 6X45 E3	343829	132	GRMB 50 E3	912018	158
BK 26	084708	137	FLDM 6X60 V	064748	132	GRS 110.100	930500	151
BK 30	084807	137	FLM 10X25 E3	343881	131	GRS 110.150	909339	151
BK 34	084906	137	FLM 10X25 F	206902	131	GRS 110.200	930517	151
BK 38	085002	137	FLM 12X30 F	207008	131	GRS 110.300	930524	151
BK 42	085101	137	FLM 6X12	206209	131	GRS 110.400	930531	151



model no.	EAN code	page	model no.	EAN code	page	model no.	EAN code	page
GRS 110.450	933969	151	GTD 600 F	136827	148	HI 80/500	178704	112
GRS 110.500	930548	151	GTD 600 S	136834	148	HI 80/600	178803	112
GRS 110.600	930555	151	GTDC 54/105 E2	136841	148	HI 80/700	178902	112
GRS 160.200 V	930623	151	GTKA 50 E3	116720	155	HI 80/800	179008	112
GRS 160.300 V	930630	151	GTKA 50 E4	136858	155	HI 80/900	179107	112
GRS 160.400 V	930647	151	GTKA 50 F	136865	155	HK 510/30	123803	124
GRS 160.450	934010	151	GTKA 50 S	967483	155	HK 510/30 F	945511	124
GRS 160.500 V	930654	151	GTL 20 E3	058075	153	HK 510/50	124008	124
GRS 160.600 V	930661	151	GTL 20 E4	057283	153	HK 510/50 F	945504	124
GRS 60.060	781904	150	GTL 20 FG	058082	153	HK 510/80 F	945535	124
GRS 60.100	781928	150	GTL 20 V	058099	153	HK 512/30 F	124251	124
GRS 60.150	781942	150	GTL 30 E3	058112	154	HK 512/50 F	124350	124
GRS 60.200	781966	150	GTL 30 E4	057290	154	HK 512/80 F	945528	124
GRS 60.300	781980	150	GTL 30 FG	058129	154	HK 610/30	124602	124
GRS 60.400	782000	150	GTL 30 V	058136	154	HK 610/30 F	945177	83
GRS 60.450	967452	150	GTL 30 V	058136	238	HK 610/30 F	945177	124
GRS 60.500	782024	150	GTL 40 E3	058143	154	HK 610/40	124701	124
GRS 60.600	782048	150	GTL 40 E4	116089	154	HK 610/50	124800	124
GRSM 6 E3	343799	154	GTL 40 FG	058150	154	HK 610/50 F	945184	83
GRSM 6 F	940554	154	GTL 40 V	058167	154	HK 610/50 F	945184	124
GRSM 6 V	280506	154	GTMB 65 E3	058181	157	HK 610/80	945498	124
GRV 6	280209	153	GTMB 65 E4	079445	157	HK 610/80 F	945481	124
GRV 6 E3	802104	153	GTMB 65 FG	058198	157	HK 612/30	124909	125
GRV 6 E5	127733	153	GTMB 65 S	058211	157	HK 612/30 F	945474	125
GRV 6 F	280186	153	GTTKS 150 E3	058631	159	HK 612/50	125005	125
GRVC 14	280308	155	GTTKS 150 S	967537	159	HK 612/50 F	945467	125
GRVC 14 E3	841509	155	GTTKS 200 E3	058648	159	HK 612/80	125050	125
GRVC 14 E5	141876	155	GTTKS 200 S	967544	159	HK 612/80 F	945450	125
GRVC 14 F	280339	155	GTTKS 300 S	967551	159	HSK 10	195800	82
GRVS 4 E3	781201	153	GTTKS 400 S	058679	159	HSK 10	195800	125
GRWVG 10 E3	931057	156	GTTKS 500 S	967568	159	HSK 10 E3	768509	125
GRWVG 10 S	280797	156	GTTKS 600 S	967575	159	HSK 15	195909	82
GRWV 20/250 E5	102198	154	GTTKSU 100 S	058693	160	HSK 15	195909	125
GRWV 20/250 F	280452	154	GTTKSU 150 S	058723	160	HSK 15 E3	768608	125
GRWV 20/250 G	101832	154	GTTKSU 200 S	058747	160	HSK 20	196104	82
GSF 0406	119608	120	GTTKSU 300 S	058761	160	HSK 20	196104	125
GSF 0408	119707	120	GTTW 2 E4	082247	160	HSK 20 E3	768707	125
GSM 0406	119202	120	GTTW 3 F	058778	160	HSK 25	196203	82
GSM 0408	119301	120	GTTW 3 S	058785	160	HSK 25	196203	125
GTAB 8 E3	136629	159	GTTW 300 S	080854	160	HSK 25 E3	768806	125
GTAB 8 E4	136636	159	GTTW 500 S	080861	160	HSK 30	196005	82
GTAB 8 F	136643	159	GTTW 600 S	082230	160	HSK 30	196005	125
GTAB 8 S	057924	159	GTVL 300 E3	058822	153	HSK 30 E3	768905	125
GTCB 50/100 E3	136650	160	GTVL 300 V	058839	153	HSK 35	196302	82
GTCB 50/100 F	136667	160	GWU 12	109609	138	HSK 35	196302	125
GTCB 50/100 S	136674	160	GWU 14	109708	138	HSK 35 E3	769001	125
GTD 100 E3	136490	148	GWU 16	110001	138	HSK 40	196401	82
GTD 100 E4	136506	148	GWU 18	110100	138	HSK 40	196401	125
GTD 100 F	057986	148	GWU 22	110209	138	HSK 40 E3	769100	125
GTD 100 S	057993	148	GWU 26	110308	138	HSKS 10	196425	87
{GTD 150 E3}	136513	148	GWU 30	110407	138	HSKS 10	196425	125
{GTD 150 E4}	136520	148	GWU 34	110506	138	HSKS 15	196432	87
{GTD 150 F}	136681	148	GWU 38	110605	138	HSKS 15	196432	125
{GTD 150 S}	092796	148	GWU 42	110704	138	HSKS 20	196449	87
GTD 200 E3	136537	148	GWU 46	110803	138	HSKS 20	196449	125
GTD 200 E4	136544	148	GWU 50	110902	138	HSKS 25	196456	87
GTD 200 F	058013	148	GWU 54	111008	138	HSKS 25	196456	125
GTD 200 S	058020	148	GWU 58	111107	138	HSKS 30	196463	87
GTD 300 E3	136551	148	GWU 64	111206	138	HSKS 30	196463	125
GTD 300 E4	136568	148	HDS 50.50 F	931705	101	HSKS 35	196470	87
GTD 300 F	058037	148	HDS 60.40 E3	931743	108	HSKS 35	196470	125
GTD 300 S	058044	148	HDS 60.40 F	931729	108	HSKS 40	196487	87
GTD 400 E3	136698	148	HI 80/1000	179206	112	HSKS 40	196487	125
GTD 400 E4	136704	148	HI 80/1100	179305	112	HU 5050/1000	858880	100
GTD 400 F	136711	148	HI 80/1200	179404	112	HU 5050/1200	858927	100
GTD 400 S	136728	148	HI 80/1300	179503	112	HU 5050/1500	858941	100
GTD 50 E3	136735	148	HI 80/1400	179602	112	HU 5050/200	858705	100
GTD 50 E3	136742	148	HI 80/1500	179701	112	HU 5050/2000	858965	100
GTD 50 F	136759	148	HI 80/1600	179800	112	HU 5050/250	858729	100
GTD 50 S	066094	148	HI 80/1700	179909	112	HU 5050/300	858743	100
GTD 500 E3	136766	148	HI 80/1800	180004	112	HU 5050/400	858767	100
GTD 500 E4	136773	148	HI 80/1900	180103	112	HU 5050/500	858781	100
GTD 500 F	136780	148	HI 80/200	178407	112	HU 5050/600	858804	100
GTD 500 S	136797	148	HI 80/2000	180202	112	HU 5050/700	858828	100
GTD 600 E3	136803	148	HI 80/300	178506	112	HU 5050/800	858842	100
GTD 600 E4	136810	148	HI 80/400	178605	112	HU 5050/900	858866	100

LIST OF ITEMS

model no.	EAN code	page	model no.	EAN code	page	model no.	EAN code	page
HU 6040/1000	891542	106	KIQ 80	903009	261	KLMUAT 40.700 F	935307	270
HU 6040/1000 E3	891917	106	KKAT 300	815708	81	KLMUAT 40.900 F	935321	270
HU 6040/1200	891566	106	KKATS 400 F	081752	85	KLMUB 40.100 F	082391	270
HU 6040/1200 E3	891931	106	KL 100.203	903658	246	KLMUB 40.150 F	082414	270
HU 6040/1500	891573	106	KL 100.203 F	904006	246	KLMUB 40.200 F	072828	270
HU 6040/1500 E3	891948	106	KL 100.303	903665	246	KLMUB 40.300 F	060511	270
HU 6040/200	891450	106	KL 100.303 F	904020	246	KLMUB 40.400 F	060528	270
HU 6040/200 E3	891825	106	KL 100.403	903672	246	KLMUB 40.500 F	060535	270
HU 6040/2000	891580	106	KL 100.403 F	904044	246	KLMUB 40.600 F	060542	270
HU 6040/2000 E3	891955	106	KL 100.503	903689	246	KLMUB 40.700 F	080151	270
HU 6040/250	891467	106	KL 100.503 F	904068	246	KLMUB 40.900 F	082421	270
HU 6040/250 E3	891832	106	KL 100.603	903696	246	KLMUBB 40.100 F	935109	270
HU 6040/300	891474	106	KL 100.603 F	904082	246	KLMUBB 40.150 F	935116	270
HU 6040/300 E3	891849	106	KLAB 200	287406	250	KLMUBB 40.200 F	935123	270
HU 6040/400	891481	106	KLAB 200 E3	900121	250	KLMUBB 40.300 F	935147	270
HU 6040/400 E3	891856	106	KLAB 200 F	900176	250	KLMUBB 40.400 F	935154	270
HU 6040/500	891498	106	KLAB 300	287505	250	KLMUBB 40.500 F	935161	270
HU 6040/500 E3	891863	106	KLAB 300 E3	900138	250	KLMUBB 40.600 F	935178	270
HU 6040/600	891504	106	KLAB 300 F	900183	250	KLMUBB 40.700 F	935185	270
HU 6040/600 E3	891870	106	KLAB 400	287604	250	KLMUBB 40.900 F	935208	270
HU 6040/700	891511	106	KLAB 400 E3	900145	250	KLMUL 40.100 F	932825	269
HU 6040/700 E3	891887	106	KLAB 400 F	900190	250	KLMUL 40.150 E5	112715	269
HU 6040/800	891528	106	KLAB 500	287703	250	KLMUL 40.150 F	932849	269
HU 6040/800 E3	891894	106	KLAB 500 E3	900152	250	KLMUL 40.200 F	932863	269
HU 6040/900	891535	106	KLAB 500 F	900206	250	KLMUL 40.300 E5	075416	269
HU 6040/900 E3	891900	106	KLAB 600	287802	250	KLMUL 40.300 F	932900	269
HUF 50/1000	169603	92	KLAB 600 E3	900169	250	KLMUL 40.400 F	932924	269
HUF 50/1000 E3	872466	92	KLAB 600 F	900213	250	KLMUL 40.500 F	932948	269
HUF 50/200	168705	92	KLAS 100	295005	250	KLMUL 40.600 E5	075423	269
HUF 50/200 E3	327300	92	KLBG 100.203	903757	248	KLMUL 40.600 F	932962	269
HUF 50/250	168804	92	KLBG 100.203 F	904204	248	KLMUL 40.700 F	932986	269
HUF 50/300	168903	92	KLBG 100.303	903764	248	KLMUL 40.900 F	933020	269
HUF 50/300 E3	327409	92	KLBG 100.303 F	904228	248	KLMV 40	298808	269
HUF 50/400	169009	92	KLBG 100.403	903771	248	KLMV 40 E5	082384	269
HUF 50/400 E3	327508	92	KLBG 100.403 F	904242	248	KLT 100.203	903801	249
HUF 50/500	169108	92	KLBG 100.503	903788	248	KLT 100.203 F	904303	249
HUF 50/500 E3	327607	92	KLBG 100.503 F	904266	248	KLT 100.303	903818	249
HUF 50/600	169207	92	KLBG 100.603	903795	248	KLT 100.303 F	904327	249
HUF 50/600 E3	327621	92	KLBG 100.603 F	904280	248	KLT 100.403	903825	249
HUF 50/700	169306	92	KLBK 100.203	903702	248	KLT 100.403 F	904341	249
HUF 50/700 E3	872404	92	KLBK 100.203 F	904105	248	KLT 100.503	903832	249
HUF 50/800	169405	92	KLBK 100.303	903719	248	KLT 100.503 F	904365	249
HUF 50/800 E3	872428	92	KLBK 100.303 F	904129	248	KLT 100.603	903849	249
HUF 50/900	169504	92	KLBK 100.403	903726	248	KLT 100.603 F	904389	249
HUF 50/900 E3	872442	92	KLBK 100.403 F	904143	248	KLTA 100.203	913701	249
I 80/1000 FL	181100	113	KLBK 100.503	903733	248	KLTA 100.203 F	904310	249
I 80/1500 FL	181209	113	KLBK 100.503 F	904167	248	KLTA 100.303	913725	249
I 80/2000 FL	181308	113	KLBK 100.603	903740	248	KLTA 100.303 F	904334	249
I 80/3000 FL	181407	113	KLBK 100.603 F	904181	248	KLTA 100.403	913749	249
I 80/3000 FL	181407	262	KLBKDV 200	938605	252	KLTA 100.403 F	904358	249
I 80/6000 FL	181506	113	KLBKDV 200 F	938650	252	KLTA 100.503	913763	249
I 80/6000 FL	181506	262	KLBKDV 300	938612	252	KLTA 100.503 F	904372	249
K 50	347605	92	KLBKDV 300 F	938667	252	KLTA 100.603	913787	249
K 5050	347025	100	KLBKDV 400	938629	252	KLTA 100.603 F	904396	249
KA 100-600	347056	80	KLBKDV 400 F	938674	252	KLTB 6	282708	251
KA 100-600	347056	116	KLBKDV 500	938636	252	KLTB 6 E3	342006	251
KGS 100.203	903900	250	KLBKDV 500 F	938681	252	KLTB 6 E5	730407	251
KGS 100.203 F	904501	250	KLBKDV 600	938643	252	KLTB 6 F	282722	251
KGS 100.303	903917	250	KLBKDV 600 F	938698	252	KLTDV 200	938759	252
KGS 100.303 F	904525	250	KLK 100.203	903856	249	KLTDV 200 F	938803	252
KGS 100.403	903924	250	KLK 100.203 F	904402	249	KLTDV 300	938766	252
KGS 100.403 F	904549	250	KLK 100.303	903863	249	KLTDV 300 F	938810	252
KGS 100.503	903931	250	KLK 100.303 F	904426	249	KLTDV 400	938773	252
KGS 100.503 F	904563	250	KLK 100.403	903870	249	KLTDV 400 F	938827	252
KGS 100.603	903948	250	KLK 100.403 F	904440	249	KLTDV 500	938780	252
KGS 100.603 F	904587	250	KLK 100.503	903887	249	KLTDV 500 F	938834	252
KGV 100 F	906789	246	KLK 100.503 F	904464	249	KLTDV 600	938797	252
KGV 100 S	906772	246	KLK 100.603	903894	249	KLTDV 600 F	938841	252
KI 80	192908	114	KLK 100.603 F	904488	249	KLWC 11	289608	247
KI 80	192908	261	KLMUAT 40.100F	935222	270	KLWC 11 F	570409	247
KIA 80	911882	114	KLMUAT 40.150 F	935239	270	KLWC 16	289707	280
KIDK 80	195008	115	KLMUAT 40.200 F	935246	270	KLWC 16	289707	284
KIDP 80	195305	116	KLMUAT 40.300 F	935260	270	KLWC 16	289707	292
KIGV 80	193103	114	KLMUAT 40.400 F	935277	270	KLWC 16	289707	297
KIGVQ 80	922352	115	KLMUAT 40.500 F	935284	270	KLWC 16 E3	341641	280
KIQ 80	903009	114	KLMUAT 40.600 F	935291	270	KLWC 16 E3	341641	284



model no.	EAN code	page	model no.	EAN code	page	model no.	EAN code	page
KLWC 16 E3	341641	292	KTAS 200 E3	330515	109	KTUM 100 E3	329021	96
KLWC 16 E3	341641	297	KTAS 300	188505	84	KTUM 100 F	968497	96
KLWC 16 F	570508	280	KTAS 300	188505	109	KTUM 150	170432	96
KLWC 16 F	570508	284	KTAS 300 E3	330539	84	KTUM 150 F	968503	96
KLWC 16 F	570508	292	KTAS 300 E3	330539	109	KTUM 200	170449	96
KLWC 16 F	570508	297	KTAS 400	188604	84	KTUM 200 E3	329045	96
KNT 50/50	200108	128	KTAS 400	188604	109	KTUM 200 F	968510	96
KNW 50/50	199709	128	KTAS 400 E3	330553	84	KTUM 300	170463	96
KSR 20 A	946761	134	KTAS 400 E3	330553	109	KTUM 300 E3	329069	96
KSR 20 A	946761	169	KTAS 400	188703	84	KTUM 300 F	968534	96
KSR 30 A	946778	134	KTAS 500	188703	109	KTUM 400	170487	96
KSR 30 A	946778	169	KTAS 500 E3	330577	84	KTUM 400 E3	329083	96
KSR 30 A	946778	176	KTAS 500 E3	330577	109	KTUM 400 F	968541	96
KSR 40 A	946785	135	KTAS 600	188802	84	KTVW 150 F	086870	80
KSR 40 A	946785	190	KTAS 600	188802	109	KTVW 200 F	086887	80
KSR 40 A	946785	203	KTAS 600 E3	330591	84	KTVW 250 F	086894	80
KSV 100 F	906765	246	KTAS 600 E3	330591	109	KTVW 300 F	086917	80
KSV 100 S	906758	246	KTAS 700	188901	84	KTVW 350 F	086924	80
KTA 100	186907	80	KTAS 700	188901	109	KTVW 400 F	086931	80
KTA 100	186907	103	KTAS 800	189007	84	KTVW 450 F	086948	80
KTA 100 E3	330003	80	KTAS 800	189007	109	KTVW 500 F	086955	80
KTA 150	187003	80	KTAS 900	189106	84	KTVW 550 F	086962	80
KTA 150	187003	103	KTAS 900	189106	109	KTVW 600 F	086979	80
KTA 200	187102	80	KTASS 1000	189298	84	KTVW 650 F	086986	80
KTA 200	187102	103	KTASS 200	189212	84	KTVW 700 F	086993	80
KTA 200 E3	330102	80	KTASS 300	189229	84	KU 50	191901	93
KTA 250	187201	80	KTASS 400	189236	84	KU 50 E3	330607	93
KTA 250	187201	103	KTASS 500	189243	84	KU 5050	191956	102
KTA 300	187300	80	KTASS 600	189250	84	KU 6040	891771	108
KTA 300	187300	103	KTASS 700	189267	84	KU 6040 E3	892136	108
KTA 300 E3	330201	80	KTASS 800	189274	84	KUD 50	192007	93
KTA 350	187409	80	KTASS 900	189281	84	KUD 50 E3	330706	93
KTA 350	187409	103	KTC 100	859801	76	KUDK 50	194803	94
KTA 400	187508	80	KTC 200	859825	76	KUDK 50 E3	770960	94
KTA 400	187508	103	KTC 300	859849	76	KUDK 5050	194858	102
KTA 400 E3	330300	80	KTC 400	859863	76	KUDK 6040	945153	108
KTA 450	187607	80	KTCL 100	904808	76	KUGH 50	192205	94
KTA 450	187607	103	KTCL 200	904822	76	KUGH 50 E3	770922	94
KTA 500	187706	80	KTT 100	181605	116	KUGK 50	195404	95
KTA 500	187706	103	KTT 150	181704	116	KUGK 50 E3	770984	95
KTA 500 E3	330409	80	KTT 200	181803	116	KUGPK 5050	195657	103
KTA 550	187805	80	KTT 250	181902	116	KUGPK 6040	945160	109
KTA 550	187805	103	KTT 300	182008	116	KUGV 50	192106	94
KTA 600	187904	80	KTT 350	182107	116	KUGV 50 E3	770908	94
KTA 600	187904	103	KTT 400	182206	116	KUGV 5050	192151	102
KTA 600 E3	330508	80	KTT 450	182305	116	KWAT 300	838103	82
KTAM 100	186303	79	KTT 500	182404	116	KWATS 300	838202	86
KTAM 100	186303	103	KTT 550	182503	116	KWV 100 F	906802	247
KTAM 100 E3	840304	79	KTT 600	182602	116	KWV 100 S	906796	247
KTAM 100 F	968459	79	KTTSS 1000	183609	117	LED 100.100	792559	316
KTAM 100 F	968459	103	KTTSS 200	182800	117	LED 100.100 E3	524563	316
KTAM 150	078530	103	KTTSS 300	182909	117	LED 16.016	517725	309
KTAM 150 F	078578	103	KTTSS 400	183005	117	LED 16.030	517732	309
KTAM 200	186402	79	KTTSS 500	183104	117	LED 26.030	517749	309
KTAM 200	186402	103	KTTSS 600	183203	117	LED 40.040	517763	316
KTAM 200 E3	840328	79	KTTSS 700	183302	117	LED 40.040 E3	524167	316
KTAM 200 F	968466	79	KTTSS 800	183401	117	LED 40.060	517800	316
KTAM 200 F	968466	103	KTTSS 900	183500	117	LED 40.060 E3	524204	316
KTAM 250	078547	103	KTTSS 1000	183692	87	LED 60.060	517909	316
KTAM 250 F	078554	103	KTTSS 200	183616	87	LED 60.060 E3	524303	316
KTAM 300	186501	79	KTTSS 300	183623	87	LED 60.100	518005	316
KTAM 300	186501	103	KTTSS 400	183630	87	LED 60.100 E3	524402	316
KTAM 300 E3	840342	79	KTTSS 500	183647	87	LED 60.150	518104	316
KTAM 300 F	968473	79	KTTSS 600	183654	87	LED 60.200	518203	316
KTAM 300 F	968473	103	KTTSS 700	183661	87	LED 60.200 E3	524501	316
KTAM 400	186600	79	KTTSS 800	183678	87	LED 80.080	792504	316
KTAM 400	186600	103	KTTSS 900	183685	87	LED 80.080 E3	524549	316
KTAM 400 F	968480	79	KTU 100	174201	96	LER 100.100	887750	316
KTAM 400 F	968480	103	KTU 150	174300	96	LER 16.016	887606	309
KTAS 100	917457	84	KTU 200	174409	96	LER 16.030	887637	309
KTAS 100	917457	109	KTU 250	174508	96	LER 26.030	887668	309
KTAS 1000	189205	84	KTU 300	174607	96	LER 40.040	865109	316
KTAS 1000	189205	109	KTU 400	174805	96	LER 40.060	865154	316
KTAS 200	188406	84	KTU 500	175000	96	LER 60.060	865208	316
KTAS 200	188406	109	KTU 600	175208	96	LER 60.100	865253	316
KTAS 200 E3	330515	84	KTUM 100	170425	96	LER 80.080	887705	316

LIST OF ITEMS

model no.	EAN code	page	model no.	EAN code	page	model no.	EAN code	page
LES 60.150	518258	316	LUAD 60.200 E3	732906	313	LUTC 100.100	799855	315
LES 60.200	518265	316	LUIB 100.100	790357	312	LUTC 100.100 E3	798728	315
LFM 6X16-TX V	132607	237	LUIB 100.100 E3	521944	312	LUTC 40.060	514700	315
LHS 100.100 E2	517466	316	LUIB 40.040	790203	312	LUTC 40.060 E3	523603	315
LHS 60.100 E2	517206	316	LUIB 40.040 E3	521562	312	LUTC 60.060	514809	315
LHS 60.150 E2	517305	316	LUIB 40.060	512201	312	LUTC 60.060 E3	517222	315
LHS 60.200 E2	517404	316	LUIB 40.060 E3	521609	312	LUTC 60.100	514908	315
LHS 80.080 E2	517442	316	LUIB 60.060	512300	312	LUTC 60.100 E3	523801	315
LLK 100.100	789757	310	LUIB 60.060 E3	521708	312	LUTC 60.150	515004	315
LLK 100.100 E3	520633	310	LUIB 60.100	512409	312	LUTC 60.200	515103	315
LLK 16.016	506705	309	LUIB 60.100 E3	521807	312	LUTC 80.080	799800	315
LLK 16.016 E3	519828	309	LUIB 60.150	512508	312	LUTC 80.080 E3	798704	315
LLK 16.030	506804	309	LUIB 60.200	512607	312	LUWB 100.100	789955	312
LLK 16.030 E3	519842	309	LUIB 60.200 E3	521906	312	LUWB 100.100 E3	521548	312
LLK 26.030	506903	309	LUIB 80.080	790302	312	LUWB 40.040	511648	312
LLK 26.030 E3	519866	309	LUIB 80.080 E3	521920	312	LUWB 40.040 E3	521142	312
LLK 40.040	508976	310	LUIC 100.100	791552	313	LUWB 40.060	511709	312
LLK 40.040 E3	520268	310	LUIC 100.100 E3	523146	313	LUWB 40.060 E3	521203	312
LLK 40.060	509003	310	LUIC 40.040	791408	313	LUWB 60.060	511808	312
LLK 40.060 E3	520305	310	LUIC 40.040 E3	522781	313	LUWB 60.060 E3	521302	312
LLK 60.060	509102	310	LUIC 40.060	513703	313	LUWB 60.100	511907	312
LLK 60.060 E3	520404	310	LUIC 40.060 E3	522804	313	LUWB 60.100 E3	521401	312
LLK 60.100	509201	310	LUIC 60.060	513802	313	LUWB 60.150	512003	312
LLK 60.100 E3	520503	310	LUIC 40.060 E3	522903	313	LUWB 60.200	512102	312
LLK 60.150	509300	310	LUIC 60.100	513901	313	LUWB 60.200 E3	521500	312
LLK 60.200	509409	310	LUIC 60.100 E3	523009	313	LUWB 80.080	789900	312
LLK 60.200 E3	520602	310	LUIC 60.150	514007	313	LUWB 80.080 E3	521524	312
LLK 80.080	789702	310	LUIC 60.200	514106	313	LUWC 100.100	791156	314
LLK 80.080 E3	520626	310	LUIC 60.200 E3	523108	313	LUWC 100.100 E3	522767	314
LST 100	516667	311	LUIC 80.080	791507	313	LUWC 40.040	791002	314
LST 100 E3	524143	311	LUIC 80.080 E3	523122	313	LUWC 40.040 E3	522361	314
LST 16.016	516209	309	LUID 100.100 E3	075263	314	LUWC 40.060	513208	314
LST 16.030	516308	309	LUID 60.060	082834	314	LUWC 40.060 E3	522408	314
LST 26.030	516407	309	LUID 60.060 E3	732804	314	LUWC 60.060	513307	314
LST 40	516506	311	LUID 60.100	831982	314	LUWC 60.060 E3	522507	314
LST 40 E3	524006	311	LUID 60.100 E3	732500	314	LUWC 60.100	513406	314
LST 60	516605	311	LUID 60.200	832026	314	LUWC 60.100 E3	522606	314
LST 60 E3	524105	311	LUID 60.200 E3	732609	314	LUWC 60.150	513505	314
LST 80	516643	311	LUK 100.100	508945	311	LUWC 60.200	513604	314
LST 80 E3	524129	311	LUK 40.040	508921	311	LUWC 60.200 E3	522705	314
LUAB 100.100	790753	312	LUK 40.040 E3	519880	311	LUWC 80.080	791101	314
LUAB 100.100 E3	522347	312	LUK 40.060	700004	311	LUWC 80.080 E3	522743	314
LUAB 40.040	790609	312	LUK 40.060 E3	519903	311	LUWD 100.100 E3	865307	314
LUAB 40.040 E3	521968	312	LUK 60.060	700103	311	LUWD 60.060	059386	314
LUAB 40.060	512706	312	LUK 60.060 E3	520008	311	LUWD 60.060 E3	732104	314
LUAB 40.060 E3	522002	312	LUK 60.100	700202	311	LUWD 60.100	831906	314
LUAB 60.060	512805	312	LUK 60.100 E3	520107	311	LUWD 60.100 E3	732203	314
LUAB 60.060 E3	522101	312	LUK 60.150	700301	311	LUWD 60.200	831944	314
LUAB 60.100	512904	312	LUK 60.200	700400	311	LUWD 60.200 E3	732302	314
LUAB 60.100 E3	522200	312	LUK 60.200 E3	520206	311	LZTP 100	833009	311
LUAB 60.150	513000	312	LUK 80.080	508938	311	LZTP 100 E3	840403	311
LUAB 60.200	513109	312	LUK 80.080 E3	520220	311	LZTP 150	833054	311
LUAB 60.200 E3	522309	312	LUT 100.100.100	792351	315	LZTP 200	833108	311
LUAB 80.080	790708	312	LUT 100.100.100 E3	523986	315	LZTP 200 E3	840458	311
LUAB 80.080 E3	522323	312	LUT 40.040.040	792207	315	M 10/1000	203208	132
LUAC 100.100	791958	313	LUT 40.040.040 E3	523924	315	M 12/1000	345809	133
LUAC 100.100 E3	523566	313	LUT 40.060.040	792252	315	M 6/1000	919420	132
LUAC 40.040	791804	313	LUT 40.060.040 E3	523948	315	M 8/1000	203505	132
LUAC 40.040 E3	523160	313	LUT 60.060.060	515202	315	MTC 105.100 E3	713233	147
LUAC 40.060	514205	313	LUT 60.060.060 E3	798803	315	MTC 105.100 E4	714155	147
LUAC 40.060 E3	523207	313	LUT 60.100.060	515301	315	MTC 105.100 F	712151	147
LUAC 60.060	514304	313	LUT 60.100.060 E3	798810	315	MTC 105.100 V	711352	147
LUAC 60.060 E3	523306	313	LUT 60.100.100	515400	315	MTC 105.150 E3	713264	147
LUAC 60.100	514403	313	LUT 60.100.100 E3	798827	315	MTC 105.150 E4	714162	147
LUAC 60.100 E3	523405	313	LUT 60.150.060	515509	315	MTC 105.150 F	712168	147
LUAC 60.150	514502	313	LUT 60.150.100	515608	315	MTC 105.150 V	711369	147
LUAC 60.200	514601	313	LUT 60.150.150	515707	315	MTC 105.200 E3	713288	147
LUAC 60.200 E3	523504	313	LUT 60.200.060	515806	315	MTC 105.200 E4	714179	147
LUAC 80.080	791903	313	LUT 60.200.060 E3	798834	315	MTC 105.200 F	712175	147
LUAC 80.080 E3	523542	313	LUT 60.200.100	515905	315	MTC 105.200 V	711376	147
LUAD 100.100 E3	075256	313	LUT 60.200.100 E3	798841	315	MTC 105.300 E3	713318	147
LUAD 60.060	926480	313	LUT 60.200.150	516001	315	MTC 105.300 E4	714186	147
LUAD 60.060 E3	732708	313	LUT 60.200.200	516100	315	MTC 105.300 F	712182	147
LUAD 60.100	832064	313	LUT 60.200.200 E3	798858	315	MTC 105.300 V	711383	147
LUAD 60.100 E3	732807	313	LUT 80.080.080	792306	315	MTC 105.400 E3	713325	147
LUAD 60.200	832101	313	LUT 80.080.080 E3	523962	315	MTC 105.400 E4	714193	147



model no.	EAN code	page	model no.	EAN code	page	model no.	EAN code	page
MTC 105.400 F	712199	147	RA 60.200	763405	183	RBA 60.500	225804	182
MTC 105.400 V	711390	147	RA 60.200 E3	845347	183	RBA 60.500 F	535606	182
MTC 105.500 E3	713332	147	RA 60.200 F	540747	183	RBA 60.600	225903	182
MTC 105.500 E4	714216	147	RA 60.400	763801	183	RBA 60.600 F	535705	182
MTC 105.500 F	712212	147	RA 60.400 E3	845422	183	RBA 85.100	237807	194
MTC 105.500 V	711413	147	RA 60.400 F	540761	183	RBA 85.100 F	541409	194
MTC 105.600 E3	713349	147	RA 60.500	763900	183	RBA 85.200	237906	194
MTC 105.600 E4	714223	147	RA 60.500 E3	845446	183	RBA 85.200 F	541508	194
MTC 105.600 F	712229	147	RA 60.500 F	540778	183	RBA 85.300	238002	194
MTC 105.600 V	711420	147	RA 60.600	764006	183	RBA 85.300 F	541607	194
MTC 54.050 E3	713073	146	RA 60.600 E3	845460	183	RBA 85.400	238101	194
MTC 54.050 E4	714063	146	RA 60.600 F	540785	183	RBA 85.400 F	541706	194
MTC 54.050 F	712069	146	RA 85.200	243341	195	RBA 85.500	238200	194
MTC 54.050 V	711260	146	RA 85.200 F	546749	195	RBA 85.500 F	541805	194
MTC 54.100 E3	713080	146	RA 85.400	243365	195	RBA 85.600	238309	194
MTC 54.100 E4	714070	146	RA 85.400 F	546763	195	RBA 85.600 F	541904	194
MTC 54.100 F	712076	146	RA 85.500	243372	195	RBADVRS 100-2.0 S	133215	230
MTC 54.100 V	711277	146	RA 85.500 F	546770	195	RBADVRS 200-2.0 S	133222	230
{MTC 54.150 E3}	713097	146	RA 85.600	243389	195	RBADVRS 300-2.0 S	133239	230
{MTC 54.150 E4}	714087	146	RA 85.600 F	546787	195	RBADVRS 400-2.0 S	133246	230
{MTC 54.150 F}	712083	146	RADS 100.100 S	139958	226	RBADVRS 500-2.0 S	133253	230
{MTC 54.150 V}	711284	146	RADS 100.200 S	139965	226	RBADVRS 600-2.0 S	133260	230
MTC 54.200 E3	713110	146	RADS 100.300 S	139972	226	RBADVS 100	863105	230
MTC 54.200 E4	714094	146	RADS 100.400 S	139989	226	RBADVS 200	863129	230
MTC 54.200 F	712090	146	RADS 100.500 S	139996	226	RBADVS 300	863143	230
MTC 54.200 V	711291	146	RADS 100.600 S	140008	226	RBADVS 400	863167	230
MTC 54.300 E3	713134	146	RADS 110.100 S	140015	229	RBADVS 500	863174	230
MTC 54.300 E4	714117	146	RADS 110.200 S	140022	229	RBADVS 600	863198	230
MTC 54.300 F	712113	146	RADS 110.300 S	140039	229	RBADVSRSL 100 S	966851	231
MTC 54.300 V	711314	146	RADS 110.400 S	140046	229	RBADVSRSL 200 S	966868	231
MTC 54.400 E3	713165	146	RADS 110.500 S	140053	229	RBADVSRSL 300 S	019991	231
MTC 54.400 E4	714124	146	RADS 110.600 S	140060	229	RBADVSRSL 400 S	966882	231
MTC 54.400 F	712120	146	RAW 100.100 S	132522	226	RBADVSRSL 500 S	966899	231
MTC 54.400 V	711321	146	RAW 100.300 S	132539	226	RBADVSRSL 600 S	020027	231
MTC 54.500 E3	713189	146	RAW 110.100	764204	209	RBAS 100.100 S	129584	225
MTC 54.500 E4	714131	146	RAW 110.100	764204	229	RBAS 100.200 S	129591	225
MTC 54.500 F	712137	146	RAW 110.100 E3	840823	209	RBAS 100.300 S	129614	225
MTC 54.500 V	711338	146	RAW 110.100 F	765201	209	RBAS 100.400 S	129621	225
MTC 54.600 E3	713219	146	RAW 110.300	764600	209	RBAS 100.500 S	129638	225
MTC 54.600 E4	714148	146	RAW 110.300	764600	229	RBAS 100.600 S	129645	225
MTC 54.600 F	712144	146	RAW 110.300 E3	840908	209	RBAS 110.100	862504	227
MTC 54.600 V	711345	146	RAW 110.300 F	765607	209	RBAS 110.200	862528	227
MTCA 4 E3	713615	153	RAW 60.100	763207	183	RBAS 110.300	862542	227
MTCA 5 E3	713622	153	RAW 60.100 E3	845309	183	RBAS 110.400	862566	227
PKS M6/10-40 F	133871	130	RAW 60.100 F	540730	183	RBAS 110.500	862573	227
PKS M8/10-40 E3	126866	130	RAW 60.300	763603	183	RBAS 110.600	862597	227
PKS M8/10-40 F	077571	130	RAW 60.300 E3	845385	183	RBAV 110.100	922406	207
RA 100.200 S	132485	226	RAW 60.300 F	540754	183	RBAV 110.150	922413	207
RA 100.400 S	132492	226	RAW 85.100	243334	195	RBAV 110.200	922420	207
RA 100.500 S	132508	226	RAW 85.100 F	546732	195	RBAV 110.300	922444	207
RA 100.600 S	132515	226	RAW 85.300	243358	195	RBAV 110.400	922468	207
RA 110.050	764105	208	RAW 85.300 F	546756	195	RBAV 110.500	922482	207
RA 110.050 E3	840809	208	RBA 110.100	251209	207	{RBAV 110.600}	922505	207
RA 110.050 F	765102	208	RBA 110.100 F	547401	207	RBAV 60.100	923786	181
RA 110.150	764303	208	RBA 110.150	251254	207	RBAV 60.150	930456	181
RA 110.150 F	765300	208	RBA 110.150 F	547456	207	RBAV 60.200	923809	181
RA 110.200	764402	208	RBA 110.200	251308	207	RBAV 60.300	923823	181
RA 110.200 F	764402	228	RBA 110.200 F	547500	207	RBAV 60.400	923847	181
RA 110.200 E3	840861	208	RBA 110.300	251407	207	RBAV 60.500	923861	181
RA 110.200 F	765409	208	RBA 110.300 F	547609	207	RBAV 60.600	923885	181
RA 110.350	764709	208	RBA 110.400	251506	207	RBAV 85.100	923663	194
RA 110.350 F	765706	208	RBA 110.400 F	547708	207	RBAV 85.200	923687	194
RA 110.400	764808	208	RBA 110.500	251605	207	RBAV 85.300	923700	194
RA 110.400	764808	228	RBA 110.500 F	547807	207	RBAV 85.400	923724	194
RA 110.400 E3	840946	208	RBA 110.600	947478	207	RBAV 85.500	923748	194
RA 110.400 F	765805	208	RBA 110.600 F	133352	207	RBAV 85.600	923762	194
RA 110.500	764907	208	RBA 60.100	225200	182	RBAVD 100	922529	213
RA 110.500 E3	840960	208	RBA 60.100 F	535200	182	RBAVD 150	930463	213
RA 110.500 F	765904	208	RBA 60.150	225309	182	RBAVD 200	922543	213
RA 110.600	858606	208	RBA 60.150 F	535255	182	RBAVD 300	922567	213
RA 110.600	858606	228	RBA 60.200	225408	182	RBAVD 400	922581	213
RA 110.600 E3	149742	208	RBA 60.200 F	535309	182	RBAVD 500	922604	213
RA 110.600 F	149759	208	RBA 60.300	225606	182	RBAVD 600	922628	213
RA 60.050	763108	183	RBA 60.300 F	535408	182	RD 100	260300	152
RA 60.150	763306	183	RBA 60.400	225705	182	RD 100	260300	212
RA 60.150 F	928651	183	RBA 60.400 F	535507	182	RD 100 E3	336203	212

LIST OF ITEMS

model no.	EAN code	page	model no.	EAN code	page	model no.	EAN code	page
RD 100 F	262502	212	RDV 200 F	263806	252	RES 60.600 F	536306	182
RD 150	260409	152	RDV 300	261802	212	RES 85.100	238408	194
RD 150	260409	212	RDV 300	261802	252	RES 85.100 F	542000	194
RD 150 F	262601	212	RDV 300 E3	337101	212	RES 85.200	238507	194
RD 200	260508	212	RDV 300 F	264001	212	RES 85.200 F	542109	194
RD 200 E3	336302	212	RDV 300 F	264001	252	RES 85.300	238606	194
RD 200 F	262700	212	RDV 400	261901	212	RES 85.300 F	542208	194
RD 300	260706	152	RDV 400	261901	252	RES 85.400	238705	194
RD 300	260706	212	RDV 400 E3	337200	212	RES 85.400 F	542307	194
RD 300 E3	336401	212	RDV 400 F	264100	212	RES 85.500	238804	194
RD 300 F	262908	212	RDV 400 F	264100	252	RES 85.500 F	542406	194
RD 400	260805	152	RDV 50	261208	167	RES 85.600	238903	194
RD 400	260805	212	RDV 500	262007	212	RES 85.600 F	542505	194
RD 400 E3	336500	212	RDV 500	262007	252	RESDV 100	276202	214
RD 400 F	263004	212	RDV 500 E3	337309	212	RESDV 100 E3	338405	214
RD 50	260102	167	RDV 500 F	264209	212	RESDV 100 F	557202	214
RD 500	260904	152	RDV 500 F	264209	252	RESDV 150	276301	214
RD 500	260904	212	RDV 600	262205	212	RESDV 150 F	557301	214
RD 500 E3	336609	212	RDV 600	262205	252	RESDV 200	275007	214
RD 500 F	263103	212	RDV 600 E3	337507	212	RESDV 200 E3	338504	214
RD 600	261109	152	RDV 600 F	264407	212	RESDV 200 F	557400	214
RD 600	261109	212	RDV 600 F	264407	252	RESDV 300	274901	214
RD 600 E3	336807	212	RDVS 100	855605	229	RESDV 300 E3	338603	214
RD 600 F	263301	212	RDVS 200	855629	229	RESDV 300 F	557608	214
RDB 85.100 V	132546	235	RDVS 300	855643	229	RESDV 400	276509	214
RDB 85.200 V	132553	235	RDVS 400	855667	229	RESDV 400 E3	338702	214
RDB 85.300 V	132560	235	RDVS 500	855681	229	RESDV 400 F	557707	214
RDB 85.400 V	132577	235	RDVS 600	855704	229	RESDV 500	276608	214
RDB 85.500 V	132584	235	RDVSRSL 100	917464	230	RESDV 500 E3	338801	214
RDB 85.600 V	132591	235	RDVSRSL 200	917488	230	RESDV 500 F	557806	214
RDHF 9 E2	920457	218	RDVSRSL 300	917501	230	RESDV 600	276806	214
RDHFS 9 F	071777	263	RDVSRSL 400	917525	230	RESDV 600 E3	338900	214
RDHFS 9 V	926282	234	RDVSRSL 500	917549	230	RESDV 600 F	558001	214
RDHFS 9 V	926282	263	RDVSRSL 600	917563	230	RESDVRS 100-2.0 S	133154	231
RDHK 110 E2	911868	217	REK 110	253203	206	RESDVRS 200-2.0 S	133161	231
RDHK 60 E2	911851	217	REK 110 E3	334902	206	RESDVRS 300-2.0 S	133178	231
RDRS 100-2.0 S	132225	230	REK 110 F	549207	206	RESDVRS 400-2.0 S	133185	231
RDRS 2	270002	169	REK 60	227600	181	RESDVRS 500-2.0 S	133192	231
RDRS 2	270002	217	REK 60 E3	334803	181	RESDVRS 600-2.0 S	133208	231
RDRS 2 E3	337606	169	REK 60 E5	729500	181	RESDVS 100	863501	231
RDRS 2 E3	337606	217	REK 60 F	537006	181	RESDVS 200	863525	231
RDRS 2 E3	337606	233	REK 85	239603	193	RESDVS 300	863549	231
RDRS 2/50	270101	169	REK 85 F	543205	193	RESDVS 400	863563	231
RDRS 2/50 E3	337651	169	RES 110.100	251803	207	RESDVS 500	863570	231
RDRS 200-2.0 S	132232	230	RES 110.100 F	548002	207	RESDVS 600	863594	231
RDRS 300-2.0 S	132249	230	RES 110.150	251858	207	RESDVSRSL 100	962075	231
RDRS 400-2.0 S	132256	230	RES 110.150 F	548057	207	RESDVSRSL 200	962082	231
RDRS 500-2.0 S	132263	230	RES 110.200	251902	207	RESDVSRSL 300	962099	231
RDRS 600-2.0 S	132270	230	RES 110.200 F	548101	207	RESDVSRSL 400	962105	231
RDRS 9	269907	217	RES 110.300	252008	207	RESDVSRSL 500	962112	231
RDRS 9	269907	253	RES 110.300 F	548200	207	RESDVSRSL 600	962129	231
RDRS 9 E3	337705	217	RES 110.400	252107	207	RESK 50.050	210305	170
RDRS 9 F	563463	217	RES 110.400 F	548309	207	RESK 50.050 F	893560	170
RDRS 9 F	563463	253	RES 110.500	252206	207	RESK 50.100	210503	170
RDRS 9X2	269884	233	RES 110.500 F	548408	207	RESKDV 100	274208	170
RDS 100	936069	229	RES 110.600	252350	207	RESKDV 50	276004	170
RDS 200	936083	229	RES 110.600 F	022717	207	RESS 100.100 S	129652	225
RDS 300	936106	229	RES 60.100	226009	182	RESS 100.200 S	129669	225
RDS 400	936120	229	RES 60.100 E3	333561	182	RESS 100.300 S	129676	225
RDS 500	936144	229	RES 60.100 F	535804	182	RESS 100.400 S	129683	225
RDS 600	936168	229	RES 60.150	226108	182	RESS 100.500 S	129690	225
RDSV 100	258208	169	RES 60.150 F	535859	182	RESS 100.600 S	129713	225
RDSV 100 E3	860609	169	RES 60.200	226207	182	RESS 110.100	862702	228
RDSV 100 F	258260	169	RES 60.200 E3	333578	182	RESS 110.200	862726	228
RDSV 50	258109	169	RES 60.200 F	535903	182	RESS 110.300	862740	228
RDSV 50 E3	860500	169	RES 60.300	226405	182	RESS 110.400	862764	228
RDSV 50 F	258246	169	RES 60.300 E3	333585	182	RESS 110.500	862771	228
RDV 100	261406	212	RES 60.300 F	536009	182	RESS 110.600	862795	228
RDV 100 E3	336906	212	RES 60.400	226504	182	RFB 110.100	814350	210
RDV 100 F	263608	212	RES 60.400 E3	845200	182	RFB 110.150	814404	210
RDV 150	261505	212	RES 60.400 F	536108	182	RFB 110.200	814459	210
RDV 150 F	263707	212	RES 60.500	226603	182	RFB 110.300	814503	210
RDV 200	261604	212	RES 60.500 E3	845231	182	RFB 110.400	814558	210
RDV 200	261604	252	RES 60.500 F	536207	182	RFB 110.500	814602	210
RDV 200 E3	337002	212	RES 60.600	226702	182	RFB 110.600	140367	210
RDV 200 F	263806	212	RES 60.600 E3	845262	182	RFD 110.100	927722	210



model no.	EAN code	page	model no.	EAN code	page	model no.	EAN code	page
RFD 110.150	927739	210	RGE 85.200 F	545902	196	RKB 600 F	564309	286
RFD 110.200	927746	210	RGE 85.300	242603	196	RKBA 10	206100	134
RFD 110.300	927760	210	RGE 85.300 F	546008	196	RKBA 10 E4	729050	134
RFD 110.400	927784	210	RGE 85.400	242702	196	RKBA 5	077991	134
RFD 110.500	927807	210	RGE 85.400 F	546107	196	RKBA 6	934805	134
RFD 110.600	927821	210	RGE 85.500	242801	196	RKS 110.100	254804	208
RFD 60.100	844319	184	RGE 85.500 F	546206	196	RKS 110.100 F	550609	208
RFD 60.100 F	935406	184	RGE 85.600	242900	196	RKS 110.150	254859	208
RFD 60.150	844333	184	RGE 85.600 F	546305	196	RKS 110.150 F	550654	208
RFD 60.200	844340	184	RGV 110	253302	209	RKS 110.200	254903	208
RFD 60.200 F	935420	184	RGV 110 E3	335107	209	RKS 110.200 F	550708	208
RFD 60.300	844364	184	RGV 110 F	253401	209	RKS 110.300	255009	208
RFD 60.300 F	935444	184	RGV 60	227709	183	RKS 110.300 F	550807	208
RFD 60.400	844371	184	RGV 60 E3	335008	183	RKS 110.400	255108	208
RFD 60.400 F	935468	184	RGV 60 F	227808	183	RKS 110.400 F	550906	208
RFD 60.500	844388	184	RGV 85	239702	195	RKS 110.500	255207	208
RFD 60.500 F	935482	184	RGV 85 F	239801	195	RKS 110.500 F	551002	208
RFD 60.600	844395	184	RKB 100	270200	185	RKS 110.600	135745	208
RFD 60.600 F	935505	184	RKB 100	270200	197	RKS 110.600 F	149599	208
RFD 85.100	927609	196	RKB 100	270200	211	RKS 60.100	229604	183
RFD 85.200	927623	196	RKB 100 E3	335503	211	RKS 60.100 F	538607	183
RFD 85.300	927647	196	RKB 100 F	563500	185	RKS 60.150	229703	183
RFD 85.400	927661	196	RKB 100 F	563500	197	RKS 60.150 F	538652	183
RFD 85.500	927685	196	RKB 100 F	563500	211	RKS 60.200	229802	183
RFD 85.600	927708	196	RKB 150	270309	185	RKS 60.200 F	538706	183
RFDDV 110.100	927968	216	RKB 150	270309	211	RKS 60.300	230006	183
RFDDV 110.150	927975	216	RKB 150 F	563609	185	RKS 60.300 F	538805	183
RFDDV 110.200	927982	216	RKB 150 F	563609	211	RKS 60.400	230105	183
RFDDV 110.300	928002	216	RKB 200	270408	185	RKS 60.400 F	538904	183
RFDDV 110.400	928026	216	RKB 200	270408	197	RKS 60.500	230204	183
RFDDV 110.500	928040	216	RKB 200	270408	211	RKS 60.500 F	539000	183
RFDDV 110.600	928064	216	RKB 200	270408	286	RKS 60.600	230303	183
RFDDV 85.100	927845	215	RKB 200 E3	335602	211	RKS 60.600 F	539109	183
RFDDV 85.200	927869	215	RKB 200 E3	335602	286	RKS 85.100	241200	195
RFDDV 85.300	927883	215	RKB 200 F	563708	185	RKS 85.100 F	544608	195
RFDDV 85.400	927906	215	RKB 200 F	563708	197	RKS 85.200	241309	195
RFDDV 85.500	927920	215	RKB 200 F	563708	211	RKS 85.200 F	544707	195
RFDDV 85.600	927944	215	RKB 200 F	563708	286	RKS 85.300	241408	195
RFSDDV 60.100	844524	215	RKB 300	270606	185	RKS 85.300 F	544806	195
RFSDDV 60.150	844562	215	RKB 300	270606	197	RKS 85.400	241507	195
RFSDDV 60.200	844586	215	RKB 300	270606	211	RKS 85.400 F	544905	195
RFSDDV 60.300	844623	215	RKB 300	270606	286	RKS 85.500	241606	195
RFSDDV 60.400	844647	215	RKB 300 E3	335701	211	RKS 85.500 F	545001	195
RFSDDV 60.500	844661	215	RKB 300 E3	335701	286	RKS 85.600	241705	195
RFSDDV 60.600	844685	215	RKB 300 F	563906	185	RKS 85.600 F	545100	195
RGE 110.100	256006	209	RKB 300 F	563906	197	RKSDV 100	278701	215
RGE 110.100 F	551804	209	RKB 300 F	563906	211	RKSDV 100 F	562602	215
RGE 110.150	256051	209	RKB 300 F	563906	286	RKSDV 150	278800	215
RGE 110.150 F	551859	209	RKB 400	270705	185	RKSDV 150 F	562701	215
RGE 110.200	256105	209	RKB 400	270705	197	RKSDV 200	278909	215
RGE 110.200 F	551903	209	RKB 400	270705	211	RKSDV 200 F	562800	215
RGE 110.300	256204	209	RKB 400	270705	286	RKSDV 300	279104	215
RGE 110.300 F	552009	209	RKB 400 E3	335800	211	RKSDV 300 F	563005	215
RGE 110.400	256303	209	RKB 400 E3	335800	286	RKSDV 400	279203	215
RGE 110.400 F	552108	209	RKB 400 F	564002	185	RKSDV 400 F	563104	215
RGE 110.500	256402	209	RKB 400 F	564002	197	RKSDV 500	279302	215
RGE 110.500 F	552207	209	RKB 400 F	564002	211	RKSDV 500 F	563203	215
RGE 110.600	140374	209	RKB 400 F	564002	286	RKSDV 600	279500	215
RGE 110.600 F	149773	209	RKB 500	270804	185	RKSDV 600 F	563401	215
RGE 60.100	231201	184	RKB 500	270804	197	RL 110.100	243402	201
RGE 60.100 F	539802	184	RKB 500	270804	211	RL 110.100 E3	332205	201
RGE 60.150	231300	184	RKB 500	270804	286	RL 110.100 F	244607	201
RGE 60.150 F	539857	184	RKB 500 E3	335909	211	RL 110.200	243501	201
RGE 60.200	231409	184	RKB 500 F	564101	185	RL 110.200 E3	332304	201
RGE 60.200 F	539901	184	RKB 500 F	564101	197	RL 110.200 F	244805	201
RGE 60.300	231607	184	RKB 500 F	564101	211	RL 110.300	243600	201
RGE 60.300 F	540006	184	RKB 500 F	564101	286	RL 110.300 E3	332403	201
RGE 60.400	231706	184	RKB 600	271009	185	RL 110.300 F	245000	201
RGE 60.400 F	540105	184	RKB 600	271009	197	RL 110.400	243709	201
RGE 60.500	231805	184	RKB 600	271009	211	RL 110.400 E3	332502	201
RGE 60.500 F	540204	184	RKB 600	271009	286	RL 110.400 F	245208	201
RGE 60.600	231904	184	RKB 600 E3	336104	211	RL 110.500	243808	201
RGE 60.600 F	540303	184	RKB 600 E3	336104	286	RL 110.500 E3	332601	201
RGE 85.100	242405	196	RKB 600 F	564309	185	RL 110.500 F	245406	201
RGE 85.100 F	545803	196	RKB 600 F	564309	197	RL 110.600	149810	201
RGE 85.200	242504	196	RKB 600 F	564309	211	RL 110.600 E3	149827	201

LIST OF ITEMS

model no.	EAN code	page	model no.	EAN code	page	model no.	EAN code	page
RL 110.600 F	139927	201	RLU 60.600 E3	332106	177	RSB 110.400	814206	209
RL 50.050	209507	167	RLU 60.600 F	222506	177	RSB 110.500	814251	209
RL 50.050/6	210008	167	RLU 85.100	232901	189	RSB 110.600	140381	209
RL 60.100	219407	177	RLU 85.100 F	234103	189	RSD 110.100	928200	210
RL 60.100 F	221202	177	RLU 85.200	233106	189	RSD 110.150	928217	210
RL 60.150	219605	177	RLU 85.200 F	234301	189	RSD 110.200	928224	210
RL 60.150 F	221400	177	RLU 85.300	233304	189	RSD 110.300	928248	210
RL 60.200	219803	177	RLU 85.300 F	234509	189	RSD 110.400	928262	210
RL 60.200 F	221509	177	RLU 85.400	233502	189	RSD 110.500	928286	210
RL 60.300	220205	177	RLU 85.400 F	234707	189	RSD 110.600	928309	210
RL 60.300 F	221806	177	RLU 85.500	233700	189	RSD 60.100	844418	184
RL 60.400	220502	177	RLU 85.500 F	234905	189	RSD 60.100 F	935604	184
RL 60.400 F	222001	177	RLU 85.600	233908	189	RSD 60.150	844432	184
RL 60.500	220809	177	RLU 85.600 F	235100	189	RSD 60.200	844449	184
RL 60.500 F	222209	177	RLVC 60.100	948178	175	RSD 60.200 F	935628	184
RL 60.600	221004	177	RLVC 60.100 E3	948239	175	RSD 60.300	844463	184
RL 60.600 F	222407	177	RLVC 60.100 E5	113088	175	RSD 60.300 F	935642	184
RL 85.100	232802	189	RLVC 60.100 F	101191	175	RSD 60.400	844470	184
RL 85.100 F	234004	189	RLVC 60.200	948161	175	RSD 60.400 F	935666	184
RL 85.200	233007	189	RLVC 60.200 E3	948246	175	RSD 60.500	844487	184
RL 85.200 F	234202	189	RLVC 60.200 E5	113071	175	RSD 60.500 F	935680	184
RL 85.300	233205	189	RLVC 60.200 F	101214	175	RSD 60.600	844494	184
RL 85.300 F	234400	189	RLVC 60.300	947300	175	RSD 60.600 F	935703	184
RL 85.400	233403	189	RLVC 60.300 E3	948253	175	RSD 85.100	928088	196
RL 85.400 F	234608	189	RLVC 60.300 E5	071470	175	RSD 85.200	928101	196
RL 85.500	233601	189	RLVC 60.300 F	101221	175	RSD 85.300	928125	196
RL 85.500 F	234806	189	RLVC 60.400	947317	175	RSD 85.400	928149	196
RL 85.600	233809	189	RLVC 60.400 E3	948260	175	RSD 85.500	928163	196
RL 85.600 F	235001	189	RLVC 60.400 E5	124725	175	RSD 85.600	928187	196
RLCI 60.100 S	135332	176	RLVC 60.400 F	101238	175	RSDDV 110.100	928446	216
RLCI 60.200 S	135356	176	RLVC 60.500	948215	175	RSDDV 110.150	928453	216
RLCI 60.300 S	135370	176	RLVC 60.500 E3	948277	175	RSDDV 110.200	928460	216
RLCI 60.400 S	144167	176	RLVC 60.500 F	101245	175	RSDDV 110.300	928484	216
RLCI 60.500 S	144181	176	RLVC 60.600	948222	175	RSDDV 110.400	928507	216
RLCI 60.600 S	144204	176	RLVC 60.600 E3	948284	175	RSDDV 110.500	928521	216
RLCPV 85.100 OV	031610	190	RLVC 60.600 F	101252	175	RSDDV 110.600	928545	216
RLCPV 85.200 OV	031627	190	RS 110.100	245802	202	RSDDV 85.100	928323	216
RLCPV 85.300 OV	031634	190	RS 110.100 F	247004	202	RSDDV 85.200	928347	216
RLCPV 85.400 OV	031641	190	RS 110.200	246007	202	RSDDV 85.300	928361	216
RLCPV 85.500 OV	031658	190	RS 110.200 F	247202	202	RSDDV 85.400	928385	216
RLCPV 85.600 OV	031665	190	RS 110.300	246205	202	RSDDV 85.500	928408	216
RLU 110.100	244003	201	RS 110.300 F	247400	202	RSDDV 85.600	928422	216
RLU 110.100 E3	332809	201	RS 110.400	246403	202	RSL 400	305445	286
RLU 110.100 F	244706	201	RS 110.400 F	247608	202	RSL 400 E3	726202	286
RLU 110.200	244102	201	RS 110.500	246601	202	RSL 400 F	593149	286
RLU 110.200 E3	332908	201	RS 110.500 F	247806	202	RSL 500	305469	286
RLU 110.200 F	244904	201	RS 110.600	140497	202	RSL 500 E3	726301	286
RLU 110.300	244201	201	RS 110.600 F	133680	202	RSL 500 F	424214	286
RLU 110.300 E3	333004	201	RS 60.100	222605	178	RSL 600	305483	286
RLU 110.300 F	245109	201	RS 60.100 F	223800	178	RSL 600 E3	726400	286
RLU 110.400	244300	201	RS 60.200	222803	178	RSL 600 F	593187	286
RLU 110.400 E3	333103	201	RS 60.200 F	224005	178	RSQLS 100.100 S OV	118250	224
RLU 110.400 F	245307	201	RS 60.300	223008	178	RSQLS 100.200 S OV	118243	224
RLU 110.500	244409	201	RS 60.300 F	224203	178	RSQLS 100.300 S OV	118236	224
RLU 110.500 E3	333202	201	RS 60.400	223206	178	RSQLS 100.400 S OV	123629	224
RLU 110.500 F	245505	201	RS 60.400 F	224401	178	RSQLS 100.500 S OV	118229	224
RLU 110.600	244553	201	RS 60.500	223404	178	RSQLS 100.600 S OV	123612	224
RLU 110.600 E3	149629	201	RS 60.500 F	224609	178	RSQLS 110.100 OV	861804	226
RLU 110.600 F	906406	201	RS 60.600	223602	178	RSQLS 110.200 OV	861828	226
RLU 60.100	219506	177	RS 60.600 F	224807	178	RSQLS 110.300 OV	861842	226
RLU 60.100 E3	331604	177	RS 85.100	235209	191	RSQLS 110.400 OV	861866	226
RLU 60.100 F	221301	177	RS 85.100 F	236404	191	RSQLS 110.500 OV	861873	226
RLU 60.150	219704	177	RS 85.200	235407	191	RSQLS 110.600 OV	861897	226
RLU 60.200	219902	177	RS 85.200 F	236602	191	RSSTAA 108.100	924288	236
RLU 60.200 E3	331703	177	RS 85.300	235605	191	RSSTAA 108.200	924301	236
RLU 60.200 F	221608	177	RS 85.300 F	236800	191	RSSTAA 108.300	924325	236
RLU 60.300	220304	177	RS 85.400	235803	191	RSSTAA 108.400	924349	236
RLU 60.300 E3	331802	177	RS 85.400 F	237005	191	RSSTAA 108.500	924363	236
RLU 60.300 F	221905	177	RS 85.500	236008	191	RSSTAA 108.600	924387	236
RLU 60.400	220601	177	RS 85.500 F	237203	191	RSSTAU 108.100 V	141890	236
RLU 60.400 E3	331901	177	RS 85.600	236206	191	RSSTAU 108.200 V	141913	236
RLU 60.400 F	222100	177	RS 85.600 F	237401	191	RSSTAU 108.300 V	141920	236
RLU 60.500	220908	177	RSB 110.100	814008	209	RSSTAU 108.400 V	141937	236
RLU 60.500 E3	332007	177	RSB 110.150	814053	209	RSSTAU 108.500 V	141944	236
RLU 60.500 F	222308	177	RSB 110.200	814107	209	RSSTAU 108.600 V	141951	236
RLU 60.600	221103	177	RSB 110.300	814152	209	RSU 110.100	245901	202



model no.	EAN code	page	model no.	EAN code	page	model no.	EAN code	page
RSU 110.100 F	247103	202	RTA 110.600 E3	149698	206	RTAKDV 50	276905	170
RSU 110.200	246106	202	RTA 110.600 F	038824	206	RTAS 100.100 S	129522	225
RSU 110.200 F	247301	202	RTA 60.100	226801	181	RTAS 100.200 S	129539	225
RSU 110.300	246304	202	RTA 60.100 E3	333608	181	RTAS 100.300 S	129546	225
RSU 110.300 F	247509	202	RTA 60.100 F	536405	181	RTAS 100.400 S	129553	225
RSU 110.400	246502	202	RTA 60.150	226900	181	RTAS 100.500 S	129560	225
RSU 110.400 F	247707	202	RTA 60.150 F	536450	181	RTAS 100.600 S	129577	225
RSU 110.500	246700	202	RTA 60.200	227006	181	RTAS 110.100	862801	228
RSU 110.500 F	247905	202	RTA 60.200 E3	333707	181	RTAS 110.200	862825	228
RSU 110.600	150137	202	RTA 60.200 F	536504	181	RTAS 110.300	862849	228
RSU 110.600 F	150052	202	RTA 60.300	227204	181	RTAS 110.400	862856	228
RSU 60.100	222704	178	RTA 60.300 E3	333806	181	RTAS 110.500	862863	228
RSU 60.100 F	223909	178	RTA 60.300 F	536603	181	RTAS 110.600	862887	228
RSU 60.200	222902	178	RTA 60.400	227303	181	RTL 110.150	793815	211
RSU 60.200 F	224104	178	RTA 60.400 E3	333905	181	RTL 110.200	793822	211
RSU 60.300	223107	178	RTA 60.400 F	536702	181	RTL 110.300	793846	211
RSU 60.300 F	224302	178	RTA 60.500	227402	181	RTL 110.400	793860	211
RSU 60.400	223305	178	RTA 60.500 E3	334001	181	RTL 110.500	793884	211
RSU 60.400 F	224500	178	RTA 60.500 F	536801	181	RTL 110.600	140435	211
RSU 60.500	223503	178	RTA 60.600	227501	181	RTL 60.100	793204	185
RSU 60.500 F	224708	178	RTA 60.600 E3	334100	181	RTL 60.150	793211	185
RSU 60.600	223701	178	RTA 60.600 F	536900	181	RTL 60.200	793228	185
RSU 60.600 F	224906	178	RTA 85.100	239009	193	RTL 60.300	793242	185
RSU 85.100	235308	191	RTA 85.100 F	542604	193	RTL 60.400	793266	185
RSU 85.100 F	236503	191	RTA 85.200	239108	193	RTL 60.500	793280	185
RSU 85.200	235506	191	RTA 85.200 F	542703	193	RTL 60.600	793303	185
RSU 85.200 F	236701	191	RTA 85.300	239207	193	RTL 85.100	793501	197
RSU 85.300	235704	191	RTA 85.300 F	542802	193	RTL 85.200	793525	197
RSU 85.300 F	236909	191	RTA 85.400	239306	193	RTL 85.300	793549	197
RSU 85.400	235902	191	RTA 85.400 F	542901	193	RTL 85.400	793563	197
RSU 85.400 F	237104	191	RTA 85.500	239405	193	RTL 85.500	793587	197
RSU 85.500	236107	191	RTA 85.500 F	543007	193	RTL 85.600	793600	197
RSU 85.500 F	237302	191	RTA 85.600	239504	193	RTPH 50	231973	180
RSU 85.600	236305	191	RTA 85.600 F	543106	193	RTPH 50	231973	192
RSU 85.600 F	237500	191	RTADV 100	277100	213	RTPH 50	231973	205
RSUV 100-1.5 S	127887	224	RTADV 100 E3	339600	213	RTPH 50 M6	961955	180
RSUV 110-1.5	862009	227	RTADV 100 F	559008	213	RTPH 50 M6	961955	193
RSUV 110-1.5/200 S	148592	205	RTADV 150	277209	213	RTPH 50 M6	961955	206
RSUV 60-1.5/200 S	148615	179	RTADV 150 F	559107	213	RTQ 110.100	793921	211
RSUV 85-1.5/200 S	134755	191	RTADV 200	277308	213	RTQ 110.150	793938	211
RSV 110.100 F	553655	203	RTADV 200 E3	339709	213	RTQ 110.200	793945	211
RSV 110.100 S	259069	203	RTADV 200 F	559206	213	RTQ 110.300	793969	211
RSV 110.150 F	553709	203	RTADV 300	274802	213	RTQ 110.400	793983	211
RSV 110.150 S	259106	203	RTADV 300 E3	339808	213	RTQ 110.500	794003	211
RSV 110.200 F	553808	203	RTADV 300 F	559404	213	RTQ 110.600	140398	211
RSV 110.200 S	259205	203	RTADV 400	277506	213	RTQ 60.100	793327	185
RSV 110.300 F	553907	203	RTADV 400 E3	339907	213	RTQ 60.150	793334	185
RSV 110.300 S	259304	203	RTADV 400 F	559503	213	RTQ 60.200	793341	185
RSV 110.400 F	554003	203	RTADV 500	277605	213	RTQ 60.300	793365	185
RSV 110.400 S	259403	203	RTADV 500 E3	340002	213	RTQ 60.400	793389	185
RSV 50.050	257706	168	RTADV 500 F	559602	213	RTQ 60.500	793402	185
RSV 50.050 E3	333523	168	RTADV 600	277803	213	RTQ 60.600	793426	185
RSV 50.050 F	258307	168	RTADV 600 E3	340101	213	RTQ 85.100	793624	197
RSV 50.050/6	257751	168	RTADV 600 F	559800	213	RTQ 85.200	793648	197
RSV 50.100	257805	168	RTADVRS 100-2.0 S	133093	232	RTQ 85.300	793662	197
RSV 50.100 E3	333547	168	RTADVRS 200-2.0 S	133109	232	RTQ 85.400	793686	197
RSV 50.100 F	258406	168	RTADVRS 300-2.0 S	133116	232	RTQ 85.500	793709	197
RSV 50.100/6	257850	168	RTADVRS 400-2.0 S	133123	232	RTQ 85.600	793723	197
RTA 110.100	252503	206	RTADVRS 500-2.0 S	133130	232	RTS 110.100	254200	208
RTA 110.100 E3	334209	206	RTADVRS 600-2.0 S	133147	232	RTS 110.100 F	550005	208
RTA 110.100 F	548606	206	RTADVS 100	863600	232	RTS 110.150	254255	208
RTA 110.150	252602	206	RTADVS 200	863624	232	RTS 110.150 F	550050	208
RTA 110.150 F	548651	206	RTADVS 300	863648	232	RTS 110.200	254309	208
RTA 110.200	252701	206	RTADVS 400	863655	232	RTS 110.200 F	550104	208
RTA 110.200 E3	334308	206	RTADVS 500	863662	232	RTS 110.300	254408	208
RTA 110.200 F	548705	206	RTADVS 600	863686	232	RTS 110.300 F	550203	208
RTA 110.300	252800	206	RTADVRSRL 100	082254	232	RTS 110.400	254507	208
RTA 110.300 E3	334407	206	RTADVRSRL 200	966387	232	RTS 110.400 F	550302	208
RTA 110.300 F	548804	206	RTADVRSRL 300	040018	232	RTS 110.500	254606	208
RTA 110.400	252909	206	RTADVRSRL 400	082261	232	RTS 110.500 F	550401	208
RTA 110.400 E3	334506	206	RTADVRSRL 500	082278	232	RTS 110.600	135769	208
RTA 110.400 F	548903	206	RTADVRSRL 600	082285	232	RTS 110.600 F	133550	208
RTA 110.500	253005	206	RTAK 50.050	210701	170	RTS 60.100	228805	182
RTA 110.500 E3	334605	206	RTAK 50.050 F	893584	170	RTS 60.100 F	538003	182
RTA 110.500 F	549009	206	RTAK 50.100	210909	170	RTS 60.150	228904	182
RTA 110.600	253159	206	RTAKDV 100	274307	170	RTS 60.150 F	538058	182

LIST OF ITEMS

model no.	EAN code	page	model no.	EAN code	page	model no.	EAN code	page
RTS 60.200	229000	182	RTSS 110.600	862993	228	RVV 110.500	260041	204
RTS 60.200 F	538102	182	RTV 110 E2	251162	155	RVV 110.500 F	554447	204
RTS 60.300	229208	182	RTV 110 E2	251162	205	RVV 110.600	150144	204
RTS 60.300 F	538201	182	RTV 110 E2	251162	284	RVV 110.600 F	150151	204
RTS 60.400	229307	182	RTV 110 E2	251162	297	RVV 50	258604	169
RTS 60.400 F	538300	182	RTV 50 E2	224999	180	RVV 50	258604	179
RTS 60.500	229406	182	RTV 60 E2	225149	155	RVV 50 E3	335404	169
RTS 60.500 F	538409	182	RTV 60 E2	225149	180	RVV 50 E3	335404	179
RTS 60.600	229505	182	RTV 85 E2	237753	192	RVV 50 E5	729906	179
RTS 60.600 F	538508	182	RTV 85 E2	237753	247	RVV 50 F	258505	169
RTS 85.100	240609	194	RTV 85 E2	237753	279	RVV 50 F	258505	179
RTS 85.100 F	544004	194	RTV 85 E2	237753	292	RW 110	251001	155
RTS 85.200	240708	194	RV 110.100	273607	204	RW 110	251001	205
RTS 85.200 F	544103	194	RV 110.100 E3	920303	204	RW 110	251001	284
RTS 85.300	240807	194	RV 110.100 F	553105	204	RW 110	251001	297
RTS 85.300 F	544202	194	RV 110.150	273652	204	RW 110 E3	333509	155
RTS 85.400	240906	194	RV 110.150 F	553150	204	RW 110 E3	333509	205
RTS 85.400 F	544301	194	RV 110.200	273706	204	RW 110 E3	333509	284
RTS 85.500	241002	194	RV 110.200 E3	920310	204	RW 110 E3	333509	297
RTS 85.500 F	544400	194	RV 110.200 F	553204	204	RW 110 E5	074518	155
RTS 85.600	241101	194	RV 110.300	273805	204	RW 110 F	251100	155
RTS 85.600 F	544509	194	RV 110.300 E3	920327	204	RW 110 F	251100	205
RTSDV 100	277902	214	RV 110.300 F	553303	204	RW 110 F	251100	284
RTSDV 100 F	560806	214	RV 110.400	273904	204	RW 110 F	251100	297
RTSDV 150	278008	214	RV 110.400 E3	920334	204	RW 50	224951	179
RTSDV 150 F	560905	214	RV 110.400 F	553402	204	RW 50 E3	333566	179
RTSDV 200	274703	214	RV 110.500	274000	204	RW 60	225002	155
RTSDV 200 F	561001	214	RV 110.500 E3	920341	204	RW 60	225002	179
RTSDV 300	278206	214	RV 110.500 F	553501	204	RW 60 E3	333400	155
RTSDV 300 F	561209	214	RV 110.600	274123	204	RW 60 E3	333400	179
RTSDV 400	278305	214	RV 110.600 E3	149858	204	RW 60 E5	729401	155
RTSDV 400 F	561308	214	RV 110.600 F	553624	204	RW 60 F	225101	155
RTSDV 500	278404	214	RV 60.100	271702	179	RW 60 F	225101	179
RTSDV 500 F	561407	214	RV 60.100 E3	336159	179	RW 85	237609	192
RTSDV 600	278602	214	RV 60.100 F	540808	179	RW 85	237609	247
RTSDV 600 F	561605	214	RV 60.150	271801	179	RW 85	237609	279
RTSDVRS 100-2.0 S	133031	233	RV 60.200	271900	179	RW 85	237609	292
RTSDVRS 200-2.0 S	133048	233	RV 60.200 E3	920259	179	RW 85 E3	333424	279
RTSDVRS 300-2.0 S	133055	233	RV 60.200 F	540907	179	RW 85 E3	333424	292
RTSDVRS 400-2.0 S	133062	233	RV 60.300	272105	179	RW 85 F	237708	192
RTSDVRS 500-2.0 S	133079	233	RV 60.300 E3	920266	179	RW 85 F	237708	247
RTSDVRS 600-2.0 S	133086	233	RV 60.300 F	541003	179	RW 85 F	237708	279
RTSDVS 100	863907	232	RV 60.400	272204	179	RW 85 F	237708	292
RTSDVS 200	863921	232	RV 60.400 E3	920273	179	RZP 100/100 S	114153	235
RTSDVS 300	863945	232	RV 60.400 F	541102	179	RZP 100/200 S	114146	235
RTSDVS 400	863969	232	RV 60.500	272303	179	RZP 100/300 S	121328	235
RTSDVS 500	863976	232	RV 60.500 E3	920280	179	RZP 100/3000 S	124749	235
RTSDVS 600	863990	232	RV 60.500 F	541201	179	RZP 100/400 S	121335	235
RTSDVSRSL 100	082292	233	RV 60.600	272402	179	RZP 100/500 S	121342	235
RTSDVSRSL 200	966394	233	RV 60.600 E3	920297	179	RZP 100/600 S	127658	235
RTSDVSRSL 300	044313	233	RV 60.600 F	541300	179	RZP 110/100 S	073382	235
RTSDVSRSL 400	068043	233	RV 85.100	272501	192	RZP 110/200 S	073399	235
RTSDVSRSL 500	082315	233	RV 85.100 F	546800	192	RZP 110/300 S	073412	235
RTSDVSRSL 600	044320	233	RV 85.200	272600	192	RZP 110/3000 S	961863	235
RTSK 50.050	211104	170	RV 85.200 F	546909	192	RZP 110/400 S	073429	235
RTSK 50.050 F	893607	170	RV 85.300	272709	192	RZP 110/500 S	073436	235
RTSK 50.100	211302	170	RV 85.300 F	547005	192	RZP 110/600 S	082322	235
RTSKDV 100	274604	171	RV 85.400	272808	192	RZP 50/100	191833	234
RTSKDV 50	274406	171	RV 85.400 F	547104	192	RZP 50/200	847907	234
RTSKQ 100-1.5 S	132188	224	RV 85.500	272907	192	RZP 50/300	847921	234
RTSKQ 100-2.0 S	124756	224	RV 85.500 F	547203	192	RZP 50/400	847945	234
RTSKQ 110-1.5 S	055227	227	RV 85.600	273003	192	RZP 50/500	847969	234
RTSKQ 110-2.0 S	055234	227	RV 85.600 F	547302	192	RZP 50/600	847983	234
RTSQF 100-1.5/1000 S	134922	224	RVC 60	870523	176	RZP 80/100	191864	234
RTSQF 110-1.5/1000 S	134946	227	RVC 85	937158	190	RZP 80/200	861200	234
RTSS 100.100 S	129720	225	RVV 110 E3	732005	204	RZP 80/300	861224	234
RTSS 100.200 S	129737	225	RVV 110.100	259663	204	RZP 80/400	861248	234
RTSS 100.300 S	129744	225	RVV 110.100 F	554058	204	RZP 80/500	861262	234
RTSS 100.400 S	129751	225	RVV 110.150	259700	204	RZP 80/600	861286	234
RTSS 100.500 S	129768	225	RVV 110.150 F	554102	204	SK 10X25 F	068319	83
RTSS 100.600 S	129775	225	RVV 110.200	259809	204	SK 10X25 F	068319	131
RTSS 110.100	862900	228	RVV 110.200 F	554201	204	SK 10X25 V	128204	131
RTSS 110.200	862924	228	RVV 110.300	259908	204	SK 10X30 E3	080946	131
RTSS 110.300	862948	228	RVV 110.300 F	554300	204	SK 10X35 F	128402	83
RTSS 110.400	862962	228	RVV 110.400	260003	204	SK 10X50 F	068326	83
RTSS 110.500	862979	228	RVV 110.400 F	554409	204	SK 10X60 F	068333	83



model no.	EAN code	page	model no.	EAN code	page	model no.	EAN code	page
SK 8X16 V	161300	131	STIC 86/906	323807	260	TW 500	204809	79
SK 8X25 F	127702	131	STUC 60/1005 F	924769	258	TW 500 E3	769605	79
SK 8X30 E3	080915	131	STUC 60/1105 F	924783	258	TW 500 F	204977	79
SKC 2991	103591	121	STUC 60/1205 F	924806	258	TW 600	204908	79
SKC 86	933105	121	STUC 60/205 F	924608	258	TW 600 E3	769704	79
SKC 88/96	926800	122	STUC 60/305 F	924622	258	TW 600 F	204984	79
SKI 80	912605	112	STUC 60/405 F	924646	258	TZK 86-96 S	073924	129
SKK 100	918423	250	STUC 60/505 F	924660	258	U 50/3000	190607	93
SKM 10X25 E3	344000	131	STUC 60/605 F	924684	258	U 50/3000 E3	330805	93
SKM 10X25 V	207305	131	STUC 60/705 F	924707	258	U 50/3000 F	190744	93
SKM 10X40 E3	344048	131	STUC 60/805 F	924721	258	U 5050/1000 F	918706	101
SKM 10X40 V	207404	131	STUC 60/905 F	924745	258	U 5050/1500 F	918768	101
SKM 10X50 V	207503	131	STVDP 30.43 F	071920	263	U 5050/2000 F	918782	101
SKM 10X70 E3	344086	131	STVDP 30.43 S	055418	263	U 5050/3000 F	859306	101
SKM 10X70 V	207541	131	STVFA 200 F	071937	263	U 5050/6000 F	859320	101
SKM 10X80 F	886203	131	STVFA 200 S	055241	263	U 6040/1000 E3	892051	107
SKM 10X90 E3	344093	131	STVFA 300 F	071944	263	U 6040/1000 F	891696	107
SKM 10X90 F	893485	131	STVFA 300 S	055258	263	U 6040/1500 E3	892082	107
SKM 12X50 F	071531	87	STVFA 400 F	071951	263	U 6040/1500 F	891726	107
SKM 12X50 V	071531	131	STVFA 400 S	055265	263	U 6040/2000 E3	892099	107
SKM 12X50 V	064731	87	STVFA 500 F	071968	263	U 6040/2000 F	891733	107
SKM 12X50 V	064731	131	STVFA 500 S	055272	263	U 6040/3000 E3	892105	107
SKM 12X70 F	071548	87	STVFA 600 F	071975	263	U 6040/3000 F	891740	107
SKM 12X70 F	071548	131	STVFA 600 S	055289	263	U 6040/3000 F	891740	259
SKM 12X70 V	207565	87	STVVA 200 F	072057	262	U 6040/6000 E3	892129	107
SKM 12X70 V	207565	131	STVVA 200 S	055357	262	U 6040/6000 F	891764	107
SKM 8X16 E3	343904	131	STVVA 300 F	072064	262	U 6040/6000 F	891764	259
SKM 8X16 V	207107	131	STVVA 300 S	055364	262	UD 24	171033	95
SKM 8X40 E3	343959	131	STVVA 400 F	072071	262	UD 24 E3	327652	95
SKU 6040	912162	106	STVVA 400 S	055371	262	UGM 10	209101	133
SKWHM 105	939350	294	STVVA 500 F	072088	262	UGM 10 E3	936854	133
SMU 10	203703	133	STVVA 500 S	055388	262	UGM 10 F	071661	133
SMU 10 E3	344260	133	STVVA 600 F	072095	262	UGM 12 E3	072385	133
SMU 12	344406	133	STVVA 600 S	055395	262	UGM 12 F	071678	133
SMU 12 E3	344284	133	TKM 1	092741	130	UGM 12 V	072378	133
SMU 8	203604	133	TKM 2	092758	130	UGM 6	208906	133
SPC 86/1000	326006	260	TKM 3	092765	130	UGM 6 E3	927258	133
SPC 86/1100	326105	260	TKS 100	183906	76	UGM 6 F	071685	133
SPC 86/1200	326204	260	TKS 100 E3	329106	76	UGM 8	209002	133
SPC 86/200	325528	260	TKS 150	184002	76	UGM 8 E3	931248	133
SPC 86/300	325542	260	TKS 200	184101	76	UGM 8 F	209057	133
SPC 86/400	325566	260	TKS 200 E3	329205	76	VB 50	199303	93
SPC 86/500	325580	260	TKS 300	184309	76	VB 50	199303	101
SPC 86/600	325603	260	TKS 300 E3	329304	76	VB 50 E3	330966	93
SPC 86/700	325702	260	TKS 400	184507	76	VB 50 E3	330966	101
SPC 86/800	325801	260	TKS 400 E3	329328	76	VB 50 E5	729005	101
SPC 86/900	325900	260	TKSD 20	185207	77	VB 6040	891788	107
SPCKL 86/1000 F	924981	258	TKSD 20 E3	329649	77	VB 6040	891788	258
SPCKL 86/1100 F	925001	258	TKSK 30	348053	78	VB 6040 E3	892143	107
SPCKL 86/1200 F	925025	258	TKSU 100	184903	78	VBASB 106.7-2.0/3000 S	15129	236
SPCKL 86/200 F	924820	258	TKSU 200	185009	78	VBASB 92.8-1.5/3000 S	132164	235
SPCKL 86/300 F	924844	258	TKSU 300	185108	78	VBI 80	199501	113
SPCKL 86/400 F	924868	258	TPS 30	459223	311	VBI 80	199501	261
SPCKL 86/500 F	924882	258	TPS 50	459247	311	VBIQ 80/140	938506	113
SPCKL 86/600 F	924905	258	TPS 50 E3	459216	311	VBSM 10	345601	133
SPCKL 86/700 F	924929	258	TPS 70	459261	311	VBSM 12	345700	133
SPCKL 86/800 F	924943	258	TPS 90	720309	311	VBSM 8	345588	133
SPCKL 86/900 F	924967	258	TPS 90 E3	865406	311	VP 50.50	209200	129
SPKGM 25 F	934959	126	TRV 40	891795	129	WA 100	189809	88
SPKM 25 F	931040	126	TRV 40 E3	892150	129	WA 150	189908	88
SPM 3000 B	047833	269	TW 100	204205	79	WA 200	190003	88
SPM 3000 E5	061778	269	TW 100 E3	769209	79	WA 250	190102	88
SPM 3000.3 AL	047840	269	TW 100 F	204915	79	WA 300	190201	88
SPPGM 30 F	930944	127	TW 150	204304	79	WA 400	190300	88
SPPM 30 F	930937	127	TW 200	204403	79	WA 500	190409	88
SSV 4141 F	898541	122	TW 200 E3	769308	79	WA 600	190508	88
STIC 86/1006	323906	260	TW 200 F	204939	79	WAER 105	949250	280
STIC 86/1106	324002	260	TW 250	204502	79	WAER 105	949250	292
STIC 86/1206	324101	260	TW 300	204601	79	WAER 105 E3	951062	280
STIC 86/206	873203	260	TW 300 E3	769407	79	WAER 105 E3	951062	292
STIC 86/306	873227	260	TW 300 F	204953	79	WAER 105 F	950188	280
STIC 86/406	873241	260	TW 350	059355	79	WAER 105 F	950188	292
STIC 86/506	873265	260	TW 350 E3	059362	79	WAER 150	949267	284
STIC 86/606	323500	260	TW 400	204700	79	WAER 150	949267	297
STIC 86/706	323609	260	TW 400 E3	769506	79	WAER 150 E3	951079	284
STIC 86/806	323708	260	TW 400 F	204960	79	WAER 150 E3	951079	297

LIST OF ITEMS

model no.	EAN code	page	model no.	EAN code	page	model no.	EAN code	page
WAER 150 F	950195	284	WRBR 150.200 E3	951130	285	WRTAR 150.400 E3	951031	285
WAER 150 F	950195	297	WRBR 150.200 F	950263	285	WRTAR 150.400 F	950102	285
WBKS 130 E3	940547	287	WRBR 150.300	949342	285	WRTAR 150.500	949182	285
WBRDV 200	966400	301	WRBR 150.300 E3	951147	285	WRTAR 150.500 E3	951048	285
WBRDV 200 E3	966509	301	WRBR 150.300 F	950270	285	WRTAR 150.500 F	950119	285
WBRDV 200 F	966455	301	WRBR 150.400	949359	285	WRTAR 150.600	949199	285
WBRDV 300	966417	301	WRBR 150.400 E3	951154	285	WRTAR 150.600 E3	951055	285
WBRDV 300 E3	966516	301	WRBR 150.400 F	950287	285	WRTAR 150.600 F	950126	285
WBRDV 300 F	966462	301	WRBR 150.500	949366	285	WRTR 105.200	949434	281
WBRDV 400	966424	301	WRBR 150.500 E3	951161	285	WRTR 105.200 E3	951185	281
WBRDV 400 E3	966523	301	WRBR 150.500 F	950294	285	WRTR 105.200 F	950362	281
WBRDV 400 F	966479	301	WRBR 150.600	949373	285	WRTR 105.300	949441	281
WBRDV 450	082759	301	WRBR 150.600 E3	951178	285	WRTR 105.300 E3	951192	281
WBRDV 450 F	082766	301	WRBR 150.600 F	950300	285	WRTR 105.300 F	950379	281
WBRDV 500	966431	301	WRL 105.200	310708	278	WRTR 105.400	949458	281
WBRDV 500 E3	966530	301	WRL 105.200 E3	724802	278	WRTR 105.400 E3	951208	281
WBRDV 500 F	966486	301	WRL 105.200 F	587803	278	WRTR 105.400 F	950386	281
WBRDV 600	966448	301	WRL 105.300	310807	278	WRTR 105.500	949465	281
WBRDV 600 E3	966547	301	WRL 105.300 E3	724826	278	WRTR 105.500 E3	951215	281
WBRDV 600 F	966493	301	WRL 105.300 F	587902	278	WRTR 105.500 F	950393	281
WBRDV 900	149728	301	WRL 105.400	310906	278	WRTR 105.600	949472	281
WBRDV 900 E3	150458	301	WRL 105.400 E3	724840	278	WRTR 105.600 E3	951222	281
WBRDV 900 F	149735	301	WRL 105.400 F	588008	278	WRTR 105.600 F	950409	281
WDRS 20	310609	302	WRL 105.500	311002	278	WRTR 150.200	949489	285
WDRS 20 E3	809004	302	WRL 105.500 E3	724864	278	WRTR 150.200 E3	951239	285
WDRS 20 F	596508	302	WRL 105.500 F	588107	278	WRTR 150.200 F	950416	285
WDV 200	309801	301	WRL 105.600	311101	278	WRTR 150.300	949496	285
WDV 200 E3	806508	301	WRL 105.600 E3	724888	278	WRTR 150.300 E3	951246	285
WDV 200 F	596003	301	WRL 105.600 F	588206	278	WRTR 150.300 F	950423	285
WDV 300	309900	301	WRL 150.200	313204	282	WRTR 150.400	949502	285
WDV 300 E3	806522	301	WRL 150.200 E3	725502	282	WRTR 150.400 E3	951253	285
WDV 300 F	596102	301	WRL 150.200 F	590506	282	WRTR 150.400 F	950430	285
WDV 400	310005	301	WRL 150.300	313303	282	WRTR 150.500	949519	285
WDV 400 E3	806546	301	WRL 150.300 E3	725526	282	WRTR 150.500 E3	951260	285
WDV 400 F	596201	301	WRL 150.300 F	590605	282	WRTR 150.500 F	950447	285
WDV 450	941940	301	WRL 150.400	313402	282	WRTR 150.600	949526	285
WDV 450 F	942886	301	WRL 150.400 E3	725540	282	WRTR 150.600 E3	951277	285
WDV 500	310104	301	WRL 150.400 F	590704	282	WRTR 150.600 F	950454	285
WDV 500 E3	806560	301	WRL 150.500	313501	282	WRU 105.200	311200	278
WDV 500 F	596300	301	WRL 150.500 E3	725564	282	WRU 105.200 F	588305	278
WDV 600	310203	301	WRL 150.500 F	590803	282	WRU 105.300	311309	278
WDV 600 E3	806584	301	WRL 150.600	313600	282	WRU 105.300 F	588404	278
WDV 600 F	596409	301	WRL 150.600 E3	725588	282	WRU 105.400	311408	278
WDV 900	941926	301	WRL 150.600 F	590902	282	WRU 105.400 F	588503	278
WDV 900 F	942916	301	WRLM 150.200	893300	283	WRU 105.500	311507	278
WLAB 200	899739	300	WRLM 150.200 F	893355	283	WRU 105.500 F	588602	278
WLAB 200 E3	900015	300	WRLM 150.300	893317	283	WRU 105.600	311606	278
WLAB 200 F	900220	300	WRLM 150.300 F	893362	283	WRU 105.600 F	588701	278
WLAB 300	899746	300	WRLM 150.400	893324	283	WRU 150.200	313709	282
WLAB 300 E3	900022	300	WRLM 150.400 F	893379	283	WRU 150.200 F	591008	282
WLAB 300 F	900237	300	WRLM 150.500	893331	283	WRU 150.300	313808	282
WLAB 400	899753	300	WRLM 150.500 F	893386	283	WRU 150.300 F	591107	282
WLAB 400 E3	900039	300	WRLM 150.600	893348	283	WRU 150.400	313907	282
WLAB 400 F	900244	300	WRLM 150.600 F	893393	283	WRU 150.400 F	591206	282
WLAB 500	899760	300	WRTAR 105.200	949106	280	WRU 150.500	314003	282
WLAB 500 E3	900046	300	WRTAR 105.200 E3	950966	280	WRU 150.500 F	591305	282
WLAB 500 F	900251	300	WRTAR 105.200 F	950034	280	WRU 150.600	314102	282
WLAB 600	899777	300	WRTAR 105.300	949113	280	WRU 150.600 F	591404	282
WLAB 600 E3	900053	300	WRTAR 105.300 E3	950973	280	WSAS 105.200 S	126897	281
WLAB 600 F	900268	300	WRTAR 105.300 F	950041	280	WSAS 105.300 S	126927	281
WRBR 105.200	949281	280	WRTAR 105.400	949120	280	WSAS 105.400 S	126941	281
WRBR 105.200E3	951086	280	WRTAR 105.400 E3	950980	280	WSAS 105.450 S	153534	281
WRBR 105.200 F	950218	280	WRTAR 105.400 F	950058	280	WSAS 105.500 S	126965	281
WRBR 105.300	949298	280	WRTAR 105.500	949137	280	WSAS 105.600 S	126989	281
WRBR 105.300E3	951093	280	WRTAR 105.500 E3	950997	280	WSAS 150.200 S	922147	286
WRBR 105.300 F	950225	280	WRTAR 105.500 F	950065	280	WSAS 150.200 S	922147	299
WRBR 105.400	949304	280	WRTAR 105.600	949144	280	WSAS 150.300 S	922161	286
WRBR 105.400E3	951109	280	WRTAR 105.600 E3	951000	280	WSAS 150.300 S	922161	299
WRBR 105.400 F	950232	280	WRTAR 105.600 F	950072	280	WSAS 150.400 S	922185	286
WRBR 105.500	949311	280	WRTAR 150.200	949151	285	WSAS 150.400 S	922185	299
WRBR 105.500E3	951116	280	WRTAR 150.200 E3	951017	285	WSAS 150.450 S	052738	286
WRBR 105.500 F	950249	280	WRTAR 150.200 F	950089	285	WSAS 150.450 S	052738	299
WRBR 105.600	949328	280	WRTAR 150.300	949168	285	WSAS 150.500 S	922208	286
WRBR 105.600E3	951123	280	WRTAR 150.300 E3	951024	285	WSAS 150.500 S	922208	299
WRBR 105.600 F	950256	280	WRTAR 150.300 F	950096	285	WSAS 150.600 S	922222	286
WRBR 150.200	949335	285	WRTAR 150.400	949175	285	WSAS 150.600 S	922222	299



model no.	EAN code	page	model no.	EAN code	page	model no.	EAN code	page
WSAS 150.900 S	052844	286	WSL 150.450	941971	295	WSTR 105.400 E3	951505	294
WSAS 150.900 S	052844	299	WSL 150.450 F	942633	295	WSTR 105.400 F	950836	294
WSBR 105.200	949731	293	WSL 150.500	301508	295	WSTR 105.450	082490	294
WSBR 105.200E3	951383	293	WSL 150.500 E3	727063	295	WSTR 105.450 F	082513	294
WSBR 105.200 F	950669	293	WSL 150.500 F	579907	295	WSTR 105.500	949915	294
WSBR 105.300	949748	293	WSL 150.600	301607	295	WSTR 105.500 E3	951512	294
WSBR 105.300E3	951390	293	WSL 150.600 E3	727087	295	WSTR 105.500 F	950843	294
WSBR 105.300 F	950676	293	WSL 150.600 F	580002	295	WSTR 105.600	949922	294
WSBR 105.400	949755	293	WSL 150.900	941957	295	WSTR 105.600 E3	951529	294
WSBR 105.400E3	951406	293	WSL 150.900 F	942671	295	WSTR 105.600 F	950850	294
WSBR 105.400 F	950683	293	WSLM 150.200	893409	296	WSTR 150.200	949939	299
WSBR 105.450	082452	293	WSLM 150.200 F	579518	296	WSTR 150.200 E3	951536	299
WSBR 105.450 F	082469	293	WSLM 150.300	893416	296	WSTR 150.200 F	950867	299
WSBR 105.500	949762	293	WSLM 150.300 F	579525	296	WSTR 150.300	949946	299
WSBR 105.500E3	951413	293	WSLM 150.400	893423	296	WSTR 150.300 E3	951543	299
WSBR 105.500 F	950690	293	WSLM 150.400 F	579532	296	WSTR 150.300 F	950874	299
WSBR 105.600	949779	293	WSLM 150.450	082520	296	WSTR 150.400	949953	299
WSBR 105.600E3	951420	293	WSLM 150.450 F	082537	296	WSTR 150.400 E3	951550	299
WSBR 105.600 F	950706	293	WSLM 150.500	893430	296	WSTR 150.400 F	950881	299
WSBR 150.200	949786	298	WSLM 150.500 F	579549	296	WSTR 150.450	082698	299
WSBR 150.200 E3	951437	298	WSLM 150.600	893447	296	WSTR 150.450 F	082711	299
WSBR 150.200 F	950713	298	WSLM 150.600 F	579556	296	WSTR 150.500	949960	299
WSBR 150.300	949793	298	WSLM 150.900	082544	296	WSTR 150.500 E3	951567	299
WSBR 150.300 E3	951444	298	WSLM 150.900 F	082568	296	WSTR 150.500 F	950898	299
WSBR 150.300 F	950720	298	WSRS 105.100 S	153558	281	WSTR 150.600	949977	299
WSBR 150.400	949809	298	WSRS 105.150 S	153565	281	WSTR 150.600 E3	951574	299
WSBR 150.400 E3	951451	298	WSRS 105.200 S	153589	281	WSTR 150.600 F	950904	299
WSBR 150.400 F	950737	298	WSRS 105.300 S	153596	281	WSTR 150.900	082728	299
WSBR 150.450	082575	298	WSRS 150.100 S	922260	286	WSTR 150.900 F	082742	299
WSBR 150.450 F	082582	298	WSRS 150.100 S	922260	299	WSV 105.390	301959	279
WSBR 150.500	949816	298	WSRS 150.150 S	071074	286	WSV 105.390	301959	291
WSBR 150.500 E3	951468	298	WSRS 150.150 S	071074	299	WSV 105.390 E3	340132	279
WSBR 150.500 F	950744	298	WSRS 150.200 S	922284	286	WSV 105.390 E3	340132	291
WSBR 150.600	949823	298	WSRS 150.200 S	922284	299	WSV 105.390 F	302055	279
WSBR 150.600 E3	951475	298	WSRS 150.300 S	922307	286	WSV 105.390 F	302055	291
WSBR 150.600 F	950751	298	WSRS 150.300 S	922307	299	WSV 150.500	301706	283
WSBR 150.900	082612	298	WSTAR 105.200	949588	293	WSV 150.500	301706	296
WSBR 150.900 F	082636	298	WSTAR 105.200 E3	951284	293	WSV 150.500 E3	340149	283
WSGV 105	305100	279	WSTAR 105.200 F	950515	293	WSV 150.500 E3	340149	296
WSGV 105	305100	291	WSTAR 105.300	949595	293	WSV 150.500 F	301805	283
WSGV 105 E3	725304	279	WSTAR 105.300 E3	951291	293	WSV 150.500 F	301805	296
WSGV 105 E3	725304	291	WSTAR 105.300 F	950522	293	WSV 150.500 F	301805	296
WSGV 105 F	590308	279	WSTAR 105.400	949601	293	WSV 150.500 F	301805	296
WSGV 105 F	590308	291	WSTAR 105.400 E3	951307	293	WSV 150.500 F	301805	296
WSGV 150	305209	283	WSTAR 105.400 F	950539	293	WSV 150.500 F	301805	296
WSGV 150	305209	296	WSTAR 105.450	082476	293	WSV 150.500 F	301805	296
WSGV 150 E3	726004	283	WSTAR 105.450 F	082483	293	WSV 150.500 F	301805	296
WSGV 150 E3	726004	296	WSTAR 105.500	949618	293	WSV 150.500 F	301805	296
WSGV 150 F	593002	283	WSTAR 105.500 E3	951314	293	WSV 150.500 F	301805	296
WSGV 150 F	593002	296	WSTAR 105.500 F	950546	293	WSV 150.500 F	301805	296
WSL 105.200	300600	291	WSTAR 105.600	949625	293	WSV 150.500 F	301805	296
WSL 105.200 E3	726509	291	WSTAR 105.600 E3	951321	293	WSV 150.500 F	301805	296
WSL 105.200 F	577606	291	WSTAR 105.600 F	950553	293	WSV 150.500 F	301805	296
WSL 105.300	300709	291	WSTAR 150.200	949632	298	WSV 150.500 F	301805	296
WSL 105.300 E3	726523	291	WSTAR 150.200 F	950560	298	WSV 150.500 F	301805	296
WSL 105.300 F	577705	291	WSTAR 150.300	949649	298	WSV 150.500 F	301805	296
WSL 105.400	300808	291	WSTAR 150.300 F	950577	298	WSV 150.500 F	301805	296
WSL 105.400 E3	726547	291	WSTAR 150.400	949656	298	WSV 150.500 F	301805	296
WSL 105.400 F	577804	291	WSTAR 150.400 F	950584	298	WSV 150.500 F	301805	296
WSL 105.450	082438	291	WSTAR 150.450	082643	298	WSV 150.500 F	301805	296
WSL 105.450 F	082445	291	WSTAR 150.450 F	082667	298	WSV 150.500 F	301805	296
WSL 105.500	300907	291	WSTAR 150.500	949663	298	WSV 150.500 F	301805	296
WSL 105.500 E3	726561	291	WSTAR 150.500 F	950591	298	WSV 150.500 F	301805	296
WSL 105.500 F	577903	291	WSTAR 150.600	949670	298	WSV 150.500 F	301805	296
WSL 105.600	301003	291	WSTAR 150.600 F	950607	298	WSV 150.500 F	301805	296
WSL 105.600 E3	726585	291	WSTAR 150.900	082674	298	WSV 150.500 F	301805	296
WSL 105.600 F	578009	291	WSTAR 150.900 F	082681	298	WSV 150.500 F	301805	296
WSL 150.200	301102	295	WSTB 2	305506	300	WSV 150.500 F	301805	296
WSL 150.200 E3	727001	295	WSTB 2 E3	726424	300	WSV 150.500 F	301805	296
WSL 150.200 F	579600	295	WSTR 105.200	949885	294	WSV 150.500 F	301805	296
WSL 150.300	301201	295	WSTR 105.200 E3	951482	294	WSV 150.500 F	301805	296
WSL 150.300 E3	727025	295	WSTR 105.200 F	950812	294	WSV 150.500 F	301805	296
WSL 150.300 F	579709	295	WSTR 105.300	949892	294	WSV 150.500 F	301805	296
WSL 150.400	301300	295	WSTR 105.300 E3	951499	294	WSV 150.500 F	301805	296
WSL 150.400 E3	727049	295	WSTR 105.300 F	950829	294	WSV 150.500 F	301805	296
WSL 150.400 F	579808	295	WSTR 105.400	949908	294	WSV 150.500 F	301805	296

LIST OF ITEMS

model no.	EAN code	page	model no.	EAN code	page	model no.	EAN code	page
WTRDV 300	966561	302	WTRDV 600 E3	966691	302	WWU 150/8	194506	127
WTRDV 300 E3	966660	302	WTRDV 600 F	966646	302	WWU 150/8	194506	251
WTRDV 300 F	966615	302	WWA 100	194759	128	WWU 150/8	194506	300
WTRDV 400	966578	302	WWA 100	194759	251	WWU 150/8 E3	344307	128
WTRDV 400 E3	966677	302	WWA 100	194759	300	WWU 150/8 E3	344307	251
WTRDV 400 F	966622	302	WWA 100 E3	344345	128	WWU 150/8 E3	344307	300
WTRDV 450	082810	302	WWA 100 E3	344345	251	WWU 150/8 E5	728909	251
WTRDV 450 F	082827	302	WWA 100 E3	344345	300	ZS M10	208708	133
WTRDV 500	966585	302	WWI 80	193004	114	ZS M12	208807	133
WTRDV 500 E3	966684	302	WWI 80	193004	261	ZS M6	208500	133
WTRDV 500 F	966639	302	WWU 150	194407	128	ZS M8	208609	133
WTRDV 600	966592	302	WWU 150	194407	259			

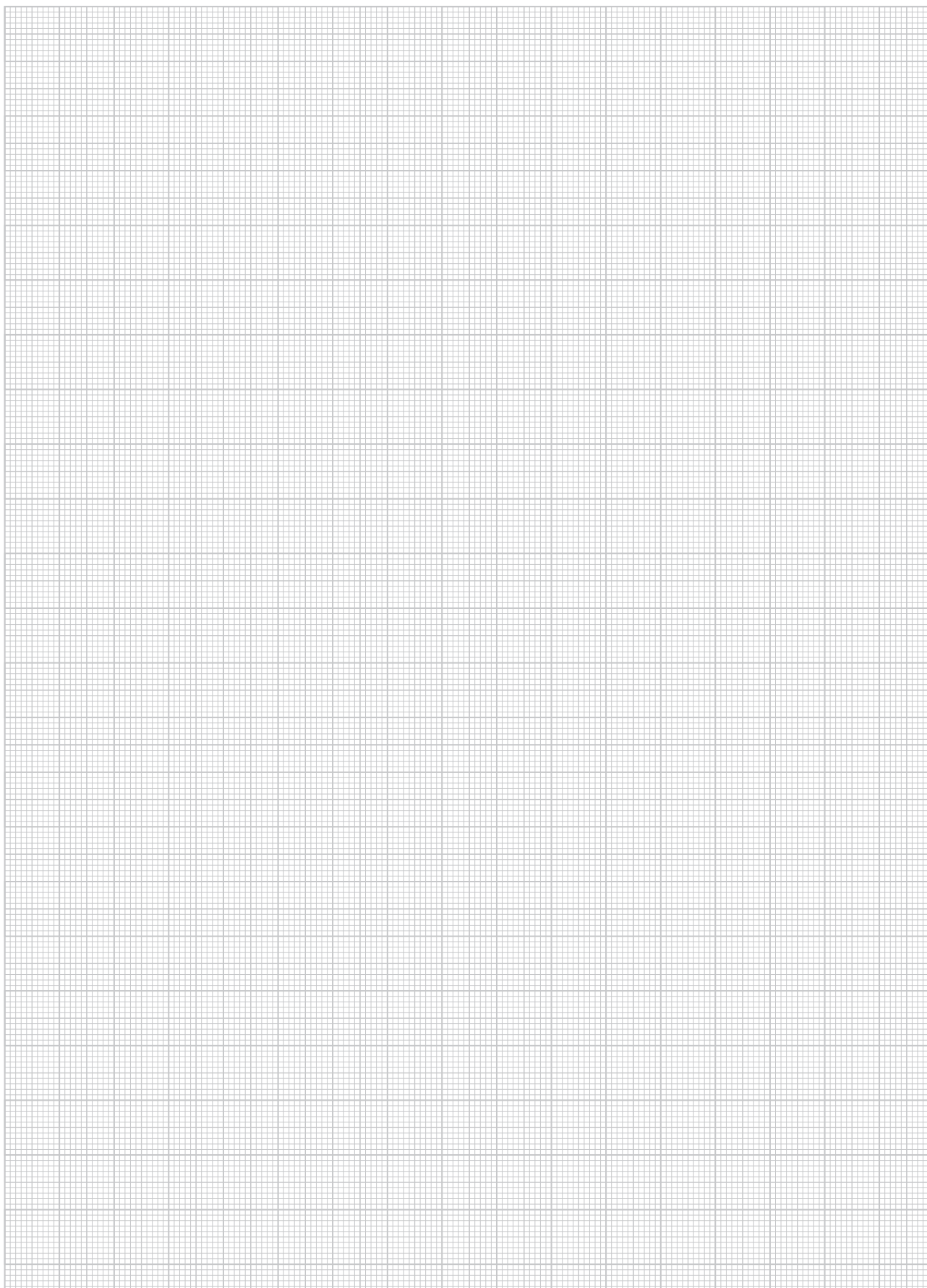

NOTES

A large rectangular area filled with a fine grid of light gray lines, intended for taking notes. The grid consists of small squares, with a slightly larger square grid pattern overlaid on top.

➔ Niedax is a privately owned company established in 1920 by two German engineers. Alexander Niedergesäß and Fritz Axthelm saw the rising demand for electricity and consequently set their focus on manufacturing electrical installation material. Being a very innovative team, they received several patents over the years, eg. for the expansion anchor in 1928 and for the yoke clamp in 1954. In 1971 Niedax launched the cable tray production, which is today the core business of the company.

In 1997 Niedax started the expansion into Europe by founding a subsidiary in Austria followed by several strategical acquisitions all over Europe. Alinco, Electraplan, Kleinhuis & RICO became valuable members of the NIEDAX GROUP.

In February 2010 Niedax celebrated it's 90th anniversary and announced the acquisition of the French cable tray manufacturers EBO, CES and Tolmega.

Niedax is a well established and highly respected company in the niche market of Cable Management Systems and one of the largest manufacturers of steel cable trays worldwide. Niedax headquarters is in Linz, Germany. The nearby manufacturing plant is located on approx. 2 million square feet in the industrial area of St. Katharinen. The factory is divided into nearly 700,000 sq.ft. of covered manufacturing and 400,000 sq.ft. of covered storage space. The remaining area is open storage for raw materials and leaves room for future expansion. Niedax is a DIN ISO 9001:2000 certified company.

Our 2000 highly motivated employees in 29 countries, state of the art machinery and top quality production methods position us to succeed in business.



Alexander Niedergesäß



Fritz Axthelm

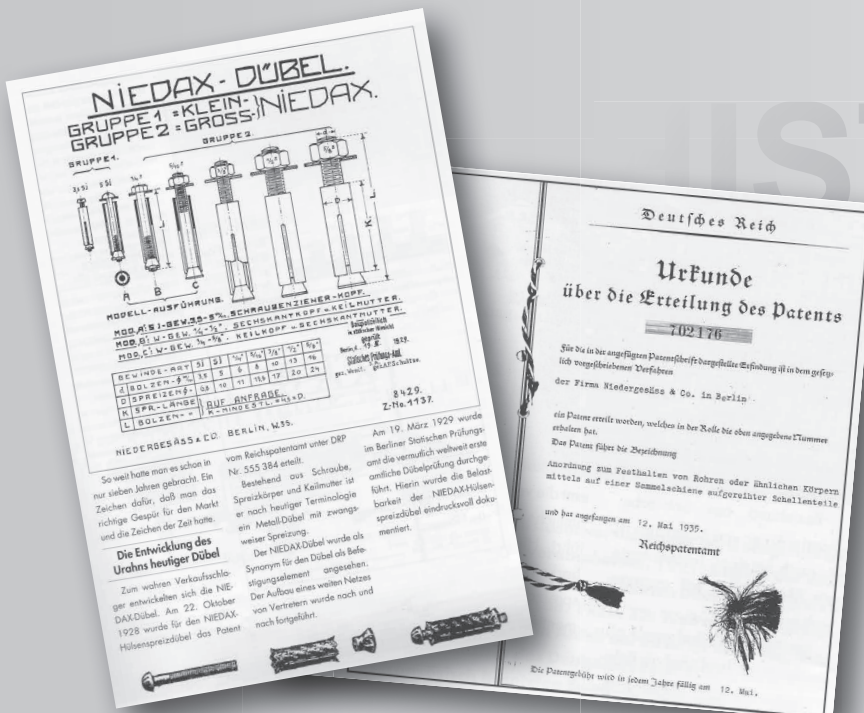

STORY

Begin 1920



THE NIEDAX GROUP



- Steel Cable Trays
- Cable Channels
- Support Systems



- PVC Cable Glands
- PVC Cable Ducting
- PVC Pipe Clamps



- Aluminium Conduit
- Aluminium Ducting
- Metric Steel Conduit



- Steel Cable Trays
- Seismic Support Systems
- Engineering Services



- Aluminium and Steel Cable Tray Systems
- Wire Mesh trays



EBO Systems

- Fiber Reinforced Polyester Cable Tray Systems
- PVC Cable Trays



- Aluminium and Steel Cable Tray Systems
- Marine Cable Ladders



- Aluminium and Steel Cable Tray Systems
- Strut Support System



- Engineering and Cable Tray Manufacturing Services for the Railway Industry



- Aluminium and Steel Cable Tray Systems
- Wire Ducting



A NIEDAX GROUP COMPANY

- US Made Wire Mesh Tray
- Steel Cable Tray System
- Marine Cable Ladders

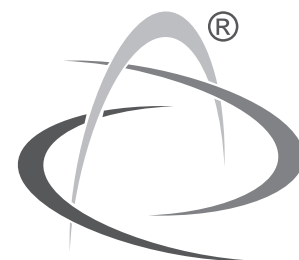

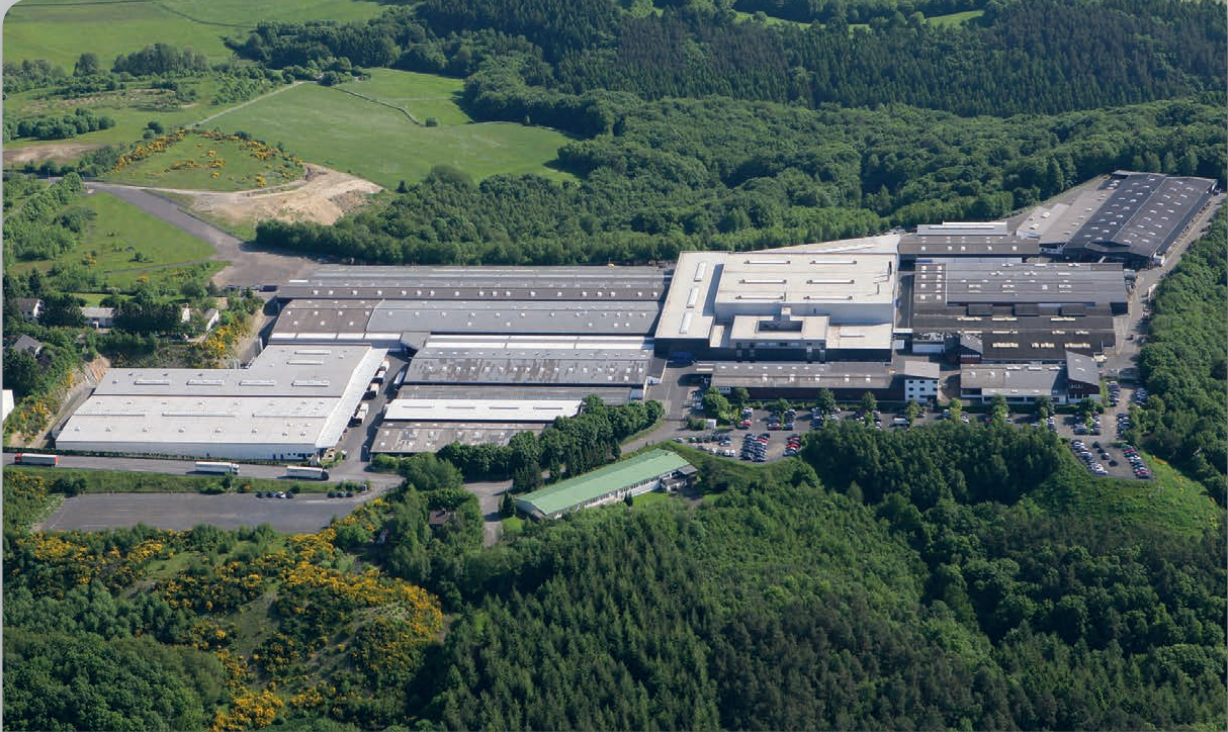

Factory and central warehouse in Germany



Headquarters in Germany





North American Headquarters at 2970 Charter St. Columbus, OH USA



Warehouse



Warehouse



Warehouse



CERTIFICATE OF COMPLIANCE

Certificate Number 20120320-E233344
Report Reference E233344-20030416
Issue Date 2012-MARCH-20
Issued to: NIEDAX GMBH & CO KG
 ASBACHER STR 141
 53545 LINZ AM RHEIN GERMANY

This is to certify that representative samples of

CABLE TRAYS
General Coverage

Have been investigated by UL in accordance with the Standard(s) indicated on this Certificate.

Standard(s) for Safety: ANSI/NFPA 70, "National Electrical Code" (NEC)
CAN/CSA-C22.2 No. 126.1-09 Standard Metal Cable Tray Systems

Additional Information: See the UL Online Certifications Directory at www.ul.com/database for additional information

Only those products bearing the UL Classification Mark for the U.S. and Canada should be considered as being covered by UL's Classification and Follow-Up Service and meeting the appropriate U.S. and Canadian requirements.

The UL Classification Mark includes: the UL in a circle symbol:  with the word "CLASSIFIED" (as shown); a control number (may be alphanumeric) assigned by UL; a statement to indicate the extent of UL's evaluation of the product; and the product category name (product identity) as indicated in the appropriate UL Directory. The UL Classification Mark for

Canada includes: the UL Classification Mark for Canada:  with the word "CLASSIFIED" (as shown); a control number (may be alphanumeric) assigned by UL; a statement to indicate the extent of UL's evaluation of the product; and the product category name (product identity) in English, French, or English/French as indicated in the appropriate UL Directory.

Look for the UL Classification Mark on the product.

William R. Carney, Director, North American Certification Programs
UL LLC

Any information and documentation involving UL Mark services are provided on behalf of UL LLC (UL) or any authorized licensee of UL. For questions, please contact a local UL Customer Service Representative at www.ul.com/contactus





CERTIFICATE NUMBER

DATE

07-HG255041-2-PDA

06 December 2013

ABS TECHNICAL OFFICE

Gdynia Engineering Department

CERTIFICATE OF DESIGN ASSESSMENT

This is to Certify that a representative of this Bureau did, at the request of
NIEDAX GmbH & Co. KG - Linz am Rhein

assess design plans and data for the below listed product. This assessment is a representation by the Bureau as to the degree of compliance the design exhibits with applicable sections of the Rules. This assessment does not waive unit certification or classification procedures required by ABS Rules for products to be installed in ABS classed vessels or facilities. This certificate, by itself, does not reflect that the product is Type Approved. The scope and limitations of this assessment are detailed on the pages attached to this certificate.

PRODUCT: **Cable Supports**

MODEL: **KLMUX 40, KLMUL 40, RSX 60, RSX 85, RSX 110, RLX 60, RLX 85, RLX 110, RLUX 60, RLUX 85, RLUX 110, RSUX 60, RSUX 85, RSUX 110, GRSX 60, GRSX 110**

This Product Design Assessment (PDA) Certificate 07-HG255041-2-PDA, dated 06/Dec/2013 remains valid until 05/Dec/2018 or until the Rules or specifications used in the assessment are revised (whichever occurs first).

This PDA is intended for a product to be installed on an ABS classed vessel, MODU or facility which is in existence or under contract for construction on the date of the ABS Rules or specifications used to evaluate the Product.

Use of the Product on an ABS classed vessel, MODU or facility which is contracted after the validity date of the ABS Rules and specifications used to evaluate the Product, will require re-evaluation of the PDA.

Use of the Product for non ABS classed vessels, MODUs or facilities is to be to an agreement between the manufacturer and intended client.

AMERICAN BUREAU OF SHIPPING

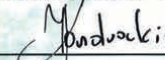
Jaroslaw Kondracki
Engineer

NOTE: This certificate evidences compliance with one or more of the Rules, Guides, standards or other criteria of ABS or a statutory, industrial or manufacturer's standards. It is issued solely for the use of ABS, its committees, its clients or other authorized entities. Any significant changes to the aforementioned product without approval from ABS will result in this certificate becoming null and void. This application/certificate is governed by the "Terms and Conditions of the Request for Product Type Approval and Agreement" as contained in the ABS Rules.



Commission Electrotechnique Internationale
 International Electrotechnical Commission
 Международная Электротехническая Комиссия

DIN EN IEC 61537:2009-09

is the Global Standard for Cable Tray and Cable Ladder Systems for Cable Management and specifies requirements and tests for cable tray systems (such as all metal cable trays including wire mesh cable tray and cable ladders) for the support, accommodation of cables and possibly other electrical equipment in electrical and/or communications systems installations.

All Niedax Support Systems are manufactured and tested in accordance with DIN EN IEC 61537 by Niedax GmbH & Co. KG in Linz/Germany.

The safe working load as defined by the standard is the lowest value of either the load creating a deflection of $L/20$ at the end or the breaking load divided by 1.7 if the deflection is not reached.

All Niedax Cable Tray and Cable Ladder Systems are manufactured and tested in accordance with DIN EN IEC 61537 by Niedax GmbH & Co. KG in Linz/Germany.

Testing is done with an equally balanced load and a splice located in the middle of the span. The safe working load is the smallest value of either the load creating a deflection of $1/100$ th of the span or the breaking load divided by 1.7. While the standard is requiring just $1/100$ th, Niedax is even more demanding and has reduced this figure to $1/200$ th.

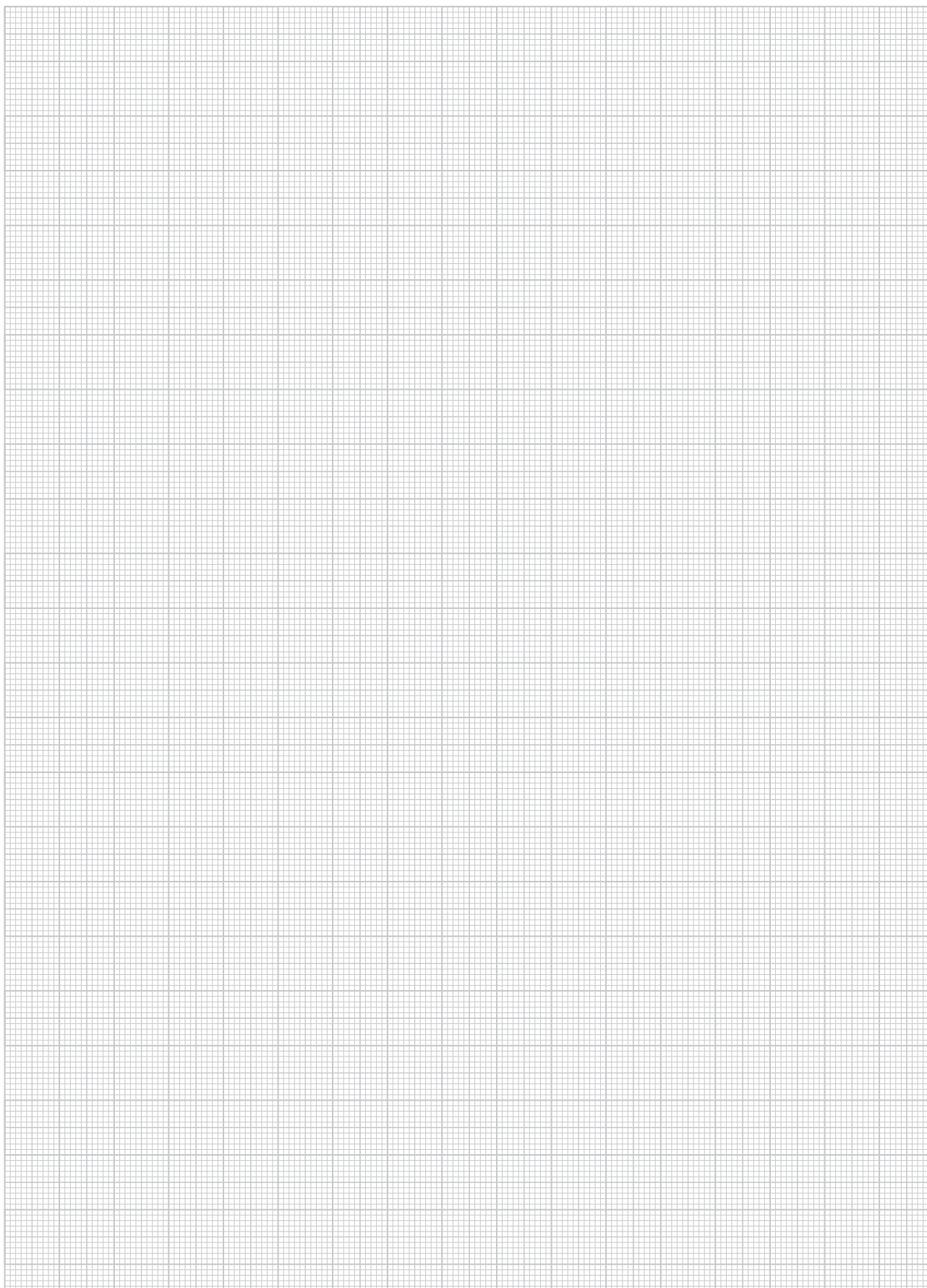

NOTES

A large rectangular area filled with a fine grid of light gray lines, intended for taking notes. The grid consists of small squares, with a slightly larger square grid pattern overlaid on top.

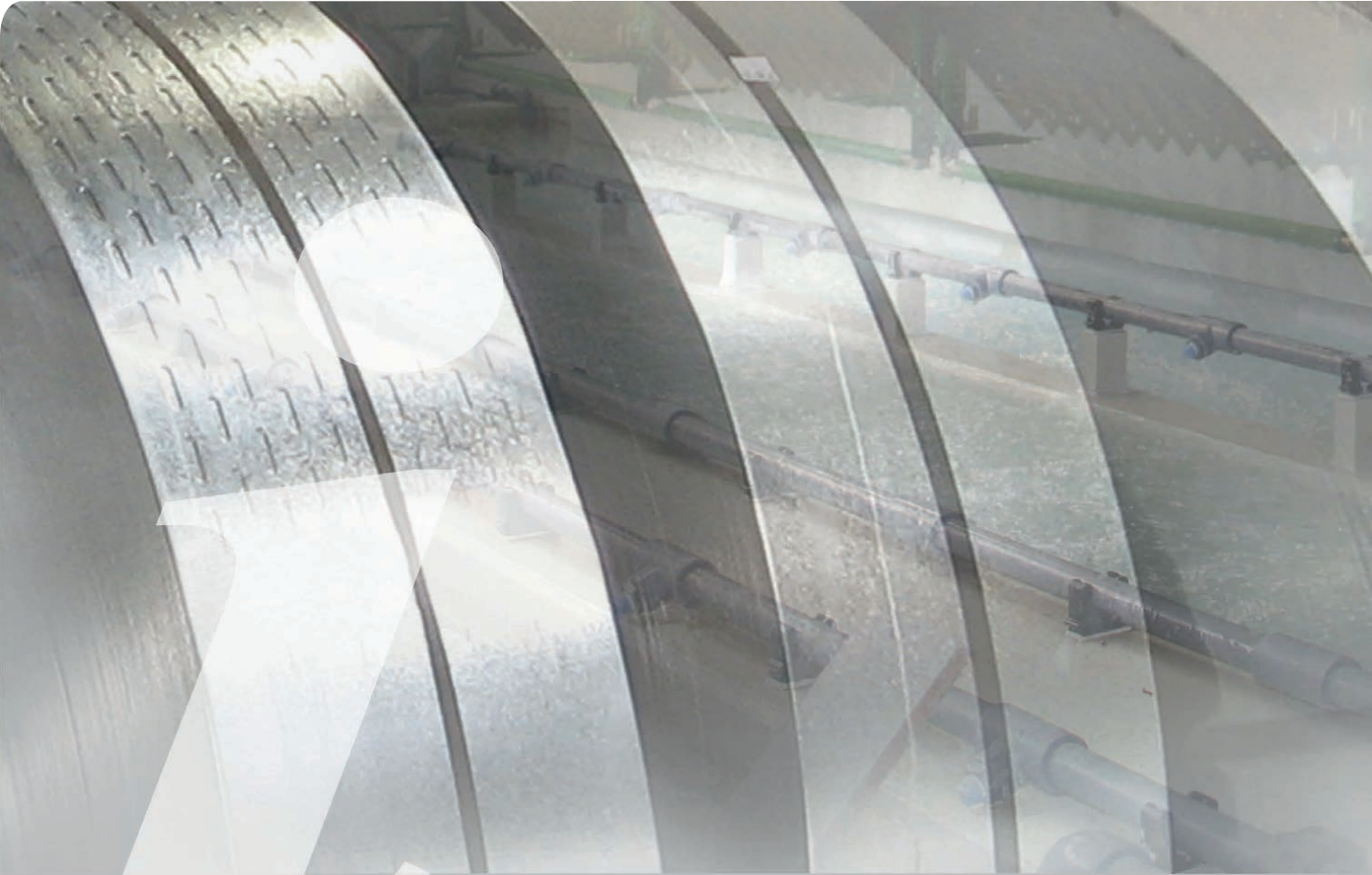

Informations

GENERAL INFORMATION

- Material Handling
- Finishes
- Corrosion Protection
- Installation Instructions

informations

INFORMATIONS

Info

WARNING!

Cable tray should not be used as a walkway, ladder, or support for people; cable tray is a mechanical support system for cables and raceways. Using cable trays as a walkway can result in personal injury and also cause damage to the cable tray system and installed cables.

Hazardous voltages in electrical equipment can cause severe personal injury or death. Safety related work practices, as described in NFPA 70E, Part 11 or VDE 0100, should be followed at all times.

The overall performance of a cable tray wiring system is dependent upon proper installation, including supports and cables.

Non-adherence to installation and maintenance guidelines may lead to personal injury as well as damage to property.

Installation and proper maintenance of cable tray wiring systems should be performed only by qualified personnel. For the purposes of this guideline, a qualified installer is one who is familiar with electrical construction. In addition, the person should be:

Trained and authorized to test, energize, clear, ground, tag, and lockout circuits in accordance with established safety practices.

Trained in the proper care and use of protective equipment such as insulated rubber gloves, hardhats, safety glasses or face shields, dust masks and flash resistant clothing in accordance with established safety practices and / or local building codes.

RECEIVING AND UNLOADING

Cable tray is generally bundled and shipped on extended pallets weighing up to 5,500 pounds. Please make sure that proper unloading equipment (e.g. forklift with extended forks) is available.

Inventory all items immediately after unloading and note on the bill of lading any shortage or shipping damage.

STORAGE

Aluminum, Fiberglass, **Stainless Steel** and /or other non-metallic cable tray can be stored outside without protective covering. Tray should be loosely stacked, elevated off the ground, and ventilated to prevent storage stain. If appearance is important, cable tray should be stored indoors to prevent water or other environmental factors from staining or adhering to cable tray.

Hot dipped galvanized after fabrication (H.D.G.A.F.), mill galvanized or electro-galvanized cable tray must be protected or stored in a well ventilated, dry location.

Bare steel cable tray should receive a protective coating as soon as possible to prevent surface rust.

PVC or painted cable tray should be protected and stored indoors if possible. Cable tray must be protected from scratching and marring of finish.



➔ NEMA LOAD CLASSIFICATION

NEMA CLASS	SUPPORT SPAN		MAX. LOAD	
	feet	meters	lbs./ft.	kg/m
5 AA	5	1,5	25	37
5 A	5	1,5	50	74
8 AA	8	2,4	25	37
8 A	8	2,4	50	74
8 B	8	2,4	75	112
8 C	8	2,4	100	149
10 AA	10	3,0	25	37
10 A	10	3,0	50	74
12 AA	12	3,7	25	37
12 A	12	3,7	50	74
12 B	12	3,7	75	112
12 C	12	3,7	100	149
20 AA	20	6,0	25	37
20 A	20	6,0	50	74
20 B	20	6,0	75	112
20 C	20	6,0	100	149

➔ CSA LOAD CLASSIFICATION

NEMA CLASS	DESIGN LOAD		SUPPORT SPACING	
	lbs./ft.	kg/m	feet	meters
A	67	99	5	1,5
A	25	37	10	3,0
C	174	259	5	1,5
C	65	97	10	3,0
D	120	179	10	3,0
D	45	67	20	6,0
E	200	299	10	3,0
E	75	112	20	6,0

The load per foot should not only include the cable, but additional load factors for wind, ice, snow, etc.

Material & Finish

STANDARDS AVAILABLE

MATERIAL	MATERIAL SPECIFICATION	ADVANTAGES
Steel	ASTM A1011 SS Gr. 33 (14 Gauge Plain Steel)	Electric Shielding
	ASTM A1008 Gr. 33 Type 2 (16 & 18 Gauge Plain Steel)	Finish Options Low Thermal Expansion
	ASTM A653SS Gr. 33 G90 (Pre-Galvanized)	Limited Deflection
Stainless Steel	AISI Type 304 and 316	Superior Corrosion Resistance
		Withstands High Temperatures

STEEL

Steel cable trays are fabricated from continuous roll-formed structural quality steel. By roll-forming steel, the mechanical properties are increased allowing the use of a lighter gauge steel to carry the required load. This reduces the dead weight that must be carried by the supports and makes the system easier to install for the contractor. By using structural quality steel, Niedax assures that the material (steel) will meet the minimum yield and tensile strengths of applicable ASTM standards. All cable tray side rails, rungs and splice plates are numbered for material identification purposes. The corrosion resistance of steel can vary widely, depending on types of coatings and alloy used.

STAINLESS STEEL

Stainless Steel cable trays are fabricated from continuous roll-formed AISI Type 304 and 316 stainless steel. They are nonmagnetic and belong to the group called austenitic stainless steels. Like carbon steel, they exhibit increased strength when cold worked by roll-forming or bending. Several important factors make the use of stainless steel imperative. Considerations such as: long term maintenance costs, corrosion resistance, appearance and locations where product contamination is undesirable, are key factors in determining the necessity of Stainless Steel Material. Stainless Steel exhibits stable structural properties such as yield strength and high creep strength at elevated temperatures. Niedax Stainless Steel cable trays are welded using stainless steel welding wire to ensure that each weld exhibits the same corrosion resistant characteristic as the base metal. A detailed study of the corrosive environment is recommended when considering a stainless steel design.

STANDARDS AVAILABLE

FINISH	SPECIFICATION	RECOMMENDED USE
Electrogalvanized Zinc	ASTM B633	Indoor
	(For Gable Tray Hardware and Accessories and Pre-Galv.)	
Pre-Galvanized Zinc	ASTM A653SS Gr.33 G90 (GSA Type 2) (Steel Gable Tray and Fittings)	Indoor
Pre-Galvanized Zinc After Fabrication	ASTM A123 (CSA Type 1) (Steel Gable Tray and Fittings)	Indoor/Outdoor

ZINC COATINGS

Zinc protects steel in two ways. First, it acts as a protective coating and secondly, as a sacrificial anode to repair bare areas such as cut edges, scratches, and gouges. The corrosion protection of zinc is directly related to its thickness and the environment. i.e., a .2 mil coating will last twice as long as a .1 mil coating in the same environment. Galvanizing also protects cut and drilled edges.



ELECTROGALVANIZED ZINC

Electrogalvanized Zinc (also known as zinc plated or electroplated) is the process by which a coating of zinc is deposited on the steel by electrolysis from a bath of zinc salts. This finish is standard for cable tray hardware and some accessories for pre-galvanized systems. When exposed to air and moisture, zinc forms a tough, adherent, protective film consisting of a mixture of zinc oxides, hydroxides, and carbonates. This film is in itself a barrier coating which slows subsequent corrosive attack on the zinc. This coating is usually only recommended for indoor use in relatively dry areas, as it provides limited protection (ninety-six hours of protection in salt spray testing per ASTM 8117).

PRE-GALVANIZED ZINC

(Mill galvanized, hot dip mill galvanized or continuous hot dip galvanized)

Pre-Galvanized steel is produced by coating coils of sheet steel with zinc. This process is accomplished by continuously rolling the material through molten zinc at the mills. This procedure is also used to produce mill galvanized and hot dip mill galvanized material. The coils are then slit to size and fabricated by roll forming, shearing, punching, or forming to produce Niedax pre-galvanized cable tray products. The G90 specification calls for a coating of .90 ounces of zinc per square foot of steel. This results in a coating of .45 ounces per square foot on each side of the sheet. This is important when comparing this finish to hot dip galvanized after fabrication. During fabrication, cut edges and welded areas are not normally zinc coated; however, the zinc located near the uncoated metal becomes a sacrificial anode to protect the bare areas within a short period of time.

HOT DIP GALVANIZED AFTER FABRICATION

(Hot dip galvanized or batch hot dip galvanized)

Hot Dip Galvanized After Fabrication cable tray products are fabricated from steel and then completely immersed in a bath of molten zinc. A metallic bond occurs resulting in a zinc coating that completely coats every surface, including edges and welds.

A key advantage of this method is coating thickness. Cable trays that are hot dip galvanized after fabrication have a minimum thickness of 1.50 ounces per square foot on each side, or a total of 3.0 ounces per square foot of steel, according to ASTM A123.

The zinc thickness can be controlled by the amount of time each part is immersed in the molten zinc bath as well as the speed at which it is removed.

The layer of zinc which bonds to the steel provides a dual protection against corrosion. It protects first as an overall barrier coating. If this coating happens to be scratched or gouged, zinc's secondary defense, galvanic action is called upon to protect the steel.

Hot dip galvanized after fabrication is recommended for prolonged outdoor exposure and will protect steel for many years in most outdoor environments as well as in many aggressive industrial environments.

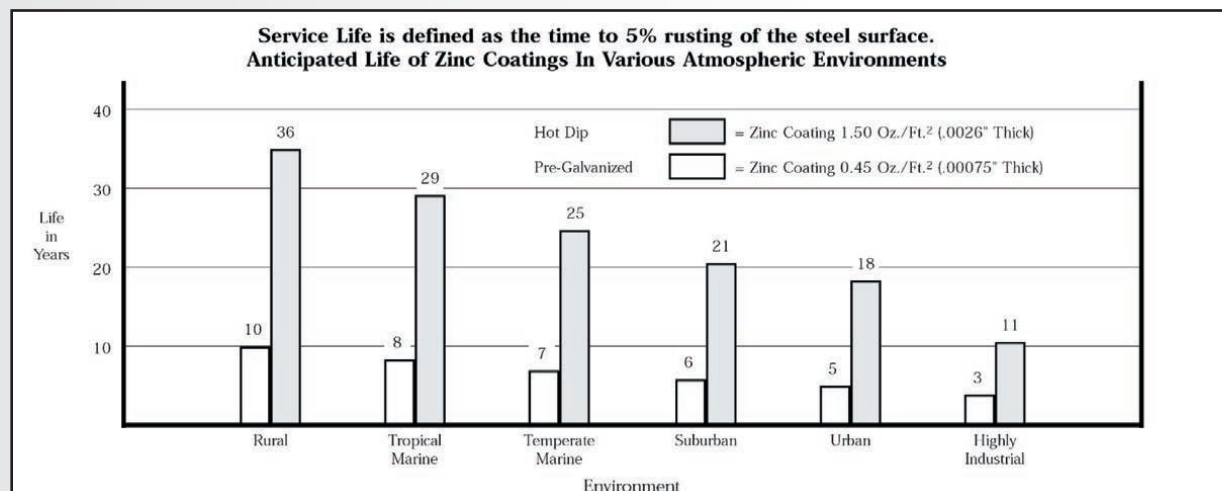

Galvanizing Processes

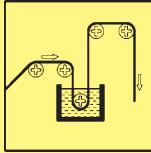
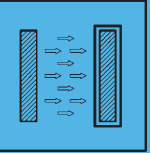
Liquid Dip Process	S	Electrolytic Process
		
Process standard		
Hot Dip Galvanizing (HDG) after fabrication according to DIN EN ISO 1461 (DIN EN ISO 10684 for hardware)	Continuous Strip Galvanization (Sendzimir Process) according to DIN EN 10 346	Electrolytic Galvanizing (Electroplating) according to DIN EN ISO 2081 (DIN EN ISO 4042 for hardware)
Structure and composition of the coating		
Alloying with the base material	Alloying with the base material	Laminated coating
Usual thickness of the zinc layer		
Depending on the thickness of the material to be galvanized, up to 1.5 mm thickness approx. 45 µm, up to 3 mm thickness approx. 55 µm, up to 6 mm thickness approx. 70 µm	Layer thickness Z 140: 10 µm + 3 µm Layer thickness Z 275: 20 µm + 5 µm according to DIN EN 10 346	approx. 2.5 to 20 µm, in undercuts and recesses (thread flanks) the layer thickness is less than on open surfaces
Special features		
Each component is individually dipped in the liquid zinc bath. The zinc washes over the entire surface. Hollow sections are protected on the in- and outside. Rigid corrosion protection	The corrosion protection layer is applied to the surface by passing the steel as a continuous ribbon through a bath of molten zinc.	The zinc layer is deposited from an aqueous electrolyte by means of DC current. Post-treatment is generally applied to improve the protective effect. Decorative visual appearance, smooth surface with no edges and burrs. 3
Distinguishing features		
The surface is relatively rough, and solidified zinc may block small holes. Newly galvanized surfaces are bright shining; high temperature galvanized part such as screws are grey.	Smooth surface depending on the process, slightly greased. Holes and cut edges expose "bare metal". Corrosion protection of "bare" edges up to 2 mm material thickness is provided by the by cathodic protection effect. 1	Iridescent shimmer, bright and shiny surface after passivation.
Usage - Application		
Welded components, equipment exposed to the weather.	Non-welded components up to 2 mm thick, especially for interior building work.	For parts in almost all shapes and sizes, corrosion protection and decorative finish. Recommended for dry, indoor areas only.
Corrosion Protection (typical annual degradation for Central Europe)		Corrosion Protection
Depending on the atmospheric conditions and the local environment. Rural 0.1 - 1.0 µm Suburban 1.0 - 2.0 µm Marine 2.0 - 4.0 µm 2	Annual degradation almost unmeasurable in dry indoor areas without pollution.	Salt spray tests according to DIN EN ISO 9227 NSS show up to 360 hours before rusting depending on the thickness of the zinc layer and the passivation method.

1 Components over 2 mm in material thickness are hot dip galvanized at Niedax

2 Local environmental conditions would be for instance the direct corrosive effect of a chimney with CO₂ flue gases.

3 Chromating process is ROHS compliant.



Corrosion

All metal surfaces are affected by corrosion. Depending on the physical properties of the metal and the environment to which it is exposed, chemical or electromechanical corrosion may occur.

→ ATMOSPHERIC CORROSION

Atmospheric corrosion occurs when metal is exposed to airborne liquids, solids or gases. Some causes of atmospheric corrosion are moisture, salt, dirt and sulphuric acid. This form of corrosion is typically worse outdoors, especially near marine environments.

→ CHEMICAL CORROSION

Chemical corrosion takes place when metal comes in direct contact with a corrosive solution. Some factors which affect the severity of chemical corrosion include: chemical concentration level, duration of contact, frequency of washing, and operating temperature.

→ STORAGE CORROSION

Wet storage stain (White rust) is caused by the entrapment of moisture between the surfaces of closely packed and poorly ventilated materials for an extended period of time. Wet storage stain is usually superficial, having no effect on the properties of the metal.

Light staining normally disappears with weathering. Medium to heavy buildup should be removed, in order to allow the formation of the normal protective film.

Proper handling and storage will help to assure stain-free material. If product arrives wet, it should be unpacked and dried before storage. Dry material should be stored in a well ventilated "low moisture" environment to avoid condensation. Outdoor storage is undesirable, and should be avoided whenever possible.

→ GALVANIC CORROSION

Galvanic corrosion occurs when two or more dissimilar metals are in contact while in the presence of an electrolyte (ie. moisture). An electrolytic cell is created and the metals form an anode or a cathode depending on their relative position on the Galvanic Series Table. The anodic material will be the one to corrode. Whether a material is anodic depends on the relative position of the other material. For example: If zinc and steel are in contact, the zinc acts as the anode and will corrode; the steel acts as the cathode, and will be protected. If steel and copper are in contact, the steel is now the anode and will corrode.

The rate at which galvanic corrosion occurs depends on several factors:

1. The amount and concentration of electrolyte present- Material stored in an indoor, dry environment will have little or no galvanic corrosion compared to a wet atmosphere.
2. The relative size of the materials- A small amount of anodic material in contact with a large cathodic material will result in greater corrosion. Likewise, a large anode in contact with a small cathode will decrease the rate of corrosive attack.
3. The relative position on the Galvanic Series Table. The farther apart in the Galvanic Series Table, the greater the potential or corrosion of the anodic material.

It is very important to consider the effects of electrolytic corrosion when selecting the assembly hardware. Ideally the finish of cable tray and hardware should be identical. But if this is not possible the relatively small hardware should always be higher grade than the large volume tray, e.g. use stainless steel bolts for hot dip galvanized tray but not the other way round.

Corrosion Guide



Chemical	Cable Tray Material					
	Stainless Type 304			Stainless Type 316		
	Cold	Warm	Hot	Cold	Warm	Hot
Acetone	R	R	R	R	R	R
Aluminium Chloride Solution	NR	–	–	F	–	–
Anhydrous Aluminium Chloride	NR	–	–	F	–	–
Aluminium Sulfate	R	R	R	R	R	R
Ammonium Chloride 10%	R	R	R	R	R	R
Ammonium Hydroxide	R	R	R	R	R	R
Ammonium Phosphate	R	–	–	R	–	–
Ammonium Sulfate	R	R	R	R	R	R
Ammonium Thiocyanate	R	–	–	R	R	R
Amyl Acetate	R	R	R	R	R	R
Amyl Alcohol	R	–	–	R	R	R
Arsenic Acid	R	R	–	R	R	R
Barium Chloride	R	R	R	R	R	R
Barium Sulfate	R	R	–	R	R	–
Barium Sulfide	R	R	–	R	R	–
Benzene	R	R	R	R	R	R
Benzoic Acid	R	R	R	R	R	R
Boric Acid	R	R	R	R	R	R
Bromine Liquid or Vapor	NR	NR	NR	NR	NR	NR
Butyl Acetate	R	–	–	R	R	R
Butyl Alcohol	R	R	R	R	R	R
Butyric Acid	R	R	R	R	R	R
Calcium Chloride 20%	R	–	–	R	–	–
Calcium Hydroxide	R	R	F	R	R	R
Calcium Hypochlorite 2 - 3%	R	–	–	R	–	–
Calcium Sulfate	R	R	–	R	R	–
Carbon Monoxide Gas	R	R	R	R	R	R
Carbon Tetrachloride	F	F	F	R	R	R
Chloroform Dry	R	R	–	R	R	–
Chloroform Solution	–	–	–	–	–	–
Chromic Acid 10% CP	R	R	F	R	R	R
Citric Acid	R	R	NR	R	R	R
Copper Cyanide	R	R	R	R	R	R
Copper Sulfate 5%	R	R	R	R	R	R
Ethyl Alcohol	R	R	R	R	R	R
Ethylene Glycol	R	R	–	R	R	R
Ferric Chloride	NR	NR	NR	NR	NR	NR
Ferrous Sulfate 10%	R	R	–	R	R	–
Formaldehyde 37%	R	R	R	R	R	R
Formic Acid 10%	R	R	NR	R	R	R
Gallic Acid 5%	R	R	R	R	R	R
Hydrochloric Acid 25%	NR	NR	NR	NR	NR	NR
Hydrofluoric Acid 10%	NR	NR	NR	NR	NR	NR

R = Recommended

F = May be used under some conditions

NR = Not Recommended

– = Information not available

Cold = 50 - 80°F

Cold = 10 - 27°F

Warm = 130 - 170°F

Warm = 54 - 77°F

Hot = 200 - 212°F

Hot = 93 - 100°F

The corrosion data given in this table is for general comparison only. (Reference Corrosion Resistance Tables, Second Edition)
The presence of contaminants in chemical environments can greatly affect the corrosion rate of any material.





Chemical	Cable Tray Material					
	Stainless Type 304			Stainless Type 316		
	Cold	Warm	Hot	Cold	Warm	Hot
Hydrogen Peroxide 30%	R	R	R	R	R	R
Hydrogen Sulfide Wet	NR	NR	R	R	R	R
Lactic Acid 10%	R	R	F	R	R	R
Lead Acetate 5%	R	R	R	R	R	R
Magnesium Chloride 1%	R	F	R	–	R	R
Magnesium Hydroxide	R	R	–	R	R	–
Magnesium Nitrate 5%	R	R	R	R	R	R
Nickel Chloride	R	–	–	R	–	–
Nitric Acid 15%	R	R	R	R	R	R
Oleic Acid	R	R	F	R	R	R
Oxalic Acid 10%	NR	NR	NR	R	R	R
Phenol CP	R	R	R	R	R	R
Phosphoric Acid 50%	R	R	R	R	F	NR
Potassium Bromide 100%	R	R	–	R	R	R
Potassium Carbonate 100%	R	R	R	R	R	R
Potassium Chloride 5%	R	R	R	R	R	R
Potassium Dichromate	R	R	R	R	R	R
Potassium Hydroxide 50%	R	R	R	R	R	R
Potassium Nitrate 50%	R	R	R	R	R	R
Potassium Sulfate 5%	R	R	R	R	R	R
Propyl Alcohol	R	R	R	R	R	R
Sodium Acetate 20%	R	R	R	R	R	R
Sodium Bisulfate 10%	R	R	R	R	–	–
Sodium Borate	R	R	R	R	R	R
Sodium Carbonate 18%	R	R	R	R	–	–
Sodium Chloride 5%	R	R	R	R	R	–
Sodium Hydroxide 50%	R	R	R	R	R	R
Sodium Hypochlorite 5%	F	–	–	R	–	–
Sodium Nitrate 100%	R	R	R	R	R	R
Sodium Nitrite 100%	R	R	R	R	R	R
Sodium Sulfate 100%	R	R	R	R	R	R
Sodium Thiosulfate	R	R	R	R	R	R
Sulfur Dioxide (Dry)	R	R	R	R	R	R
Sulfuric Acid 5%	F	NR	NR	R	–	–
Sulfuric Acid 10%	NR	NR	NR	NR	NR	NR
Sulfuric Acid 50%	NR	NR	NR	NR	NR	NR
Sulfuric Acid 75 - 98%	NR	NR	NR	NR	NR	NR
Sulfuric Acid 98 - 100%	NR	NR	–	R	R	F
Tannic Acid 10 & 50%	R	R	R	R	R	R
Tartaric Acid 10 & 50%	R	R	R	R	R	R
Vinegar	R	R	R	R	R	R
Zinc Chloride 5 & 20%	R	F	NR	R	R	R
Zinc Nitrate	R	R	R	R	R	R
Zinc Sulfate	R	R	R	R	R	R

Mechanical Properties

LENGTHS AVAILABLE

The current Cable Tray Standard, NEMA VE-1 and C22.2 No. 126.1-98, lists typical lengths as 3000 mm (10 ft), 3660 mm (12 ft), 6000 mm (20 ft), and 7320 mm (24 ft). It is impractical to manufacture either lighter systems in the longer lengths or heavier systems in the shorter lengths. For that reason, Niedax has introduced a primary and secondary length for some systems. These straight section lengths were selected to direct the user to trays that best suit support span demands and practical loading requirements. The primary length is the one that is the most appropriate for the strength of the system and that will provide the fastest service levels. The secondary lengths will be made available to service additional requirements. Special lengths are available upon request with extended lead times.

The VE-2, Cable Tray Installation Guide, states that the support span shall not be greater than the straight section length. If a 20C system is manufactured in 12 foot sections the greatest span for supports would be 12 feet. This dramatically affects the loading of the system.

$$\begin{aligned}
 W_1 \times L_1^2 &= W_2 \times L_2^2 \\
 100 \times 20^2 &= W_2 \times 12^2 \\
 40,000 &= 144 \times W_2 \\
 W_2 &= 277 \text{ lbs. per foot}
 \end{aligned}$$

SUPPORT SPAN

The strength of a cable tray system is largely determined by the strength of its side rails. The strength of a cable tray side rail is proportionate to the distance between the supports on which it is installed, commonly referred to as the "support span". Therefore, the strength of a cable tray system can be altered by changing the support span. However, there is a limit to how much that strength can be increased by reducing the support span. At a certain point the strength of the bottom portion of the cable tray could become the determining factor of strength.

Once the load requirement has been determined, the following factors should be considered:

1. Sometimes the location of existing structural beams will dictate the cable tray support span. This is typical with outdoor installations where adding intermediate supports could be financially prohibitive. For this situation the appropriate cable tray must be selected to accommodate the existing span.
2. When cable tray supports are randomly located, the added cost of a higher strength cable tray system should be compared to the cost of additional supports.
3. The support span lengths should be equal to or less than unspliced straight section lengths, to ensure that no more than one splice is placed between supports.

The distance between the supports affects the loading capabilities exponentially. To calculate loading values not listed use:

$$\begin{aligned}
 W_1 \times L_1^2 &= W_2 \times L_2^2 \text{ where} \\
 W_1 &= \text{tested loading} \\
 L_1 &= \text{span in feet, a tested span} \\
 W_2 &= \text{loading in question} \\
 L_2 &= \text{known span for new loading}
 \end{aligned}$$

Other Loads - Ice, wind, snow for outdoor systems see page 16 and 17 for information.

A 200 lb. concentrated load for industrial systems. The affect of a concentrated load can be calculated as follows:

$$2 \times (\text{concentrated static load}) / \text{span in feet}$$

When considering concentrated loads the rung strength should be factored in.



➔ DEFLECTION

Deflection in a cable tray system is primarily an aesthetic consideration. When a cable tray system is installed in a prominent location, a maximum simple beam deflection of 1/200 of support span can be used as a guideline to minimize visual deflection.

It is important at this point to mention that there are two typical beam configurations, simple beam and continuous beam, and to clarify the difference.

A good example of a simple beam is a single straight section of cable tray supported, but not fastened at either end. When the tray is loaded the cable tray is allowed to flex. Simple beam analysis is used almost universally for beam comparisons even though it is hardly practical in the field. The three most prominent reasons for using a simple beam analysis are: calculations are simplified; it represents the worst case loading; and testing is simple and reliable.

Continuous beam is the beam configuration most commonly used in cable tray installations. An example of this configuration is where cable trays are installed across several supports to form a number of spans. The continuous beam possesses traits of both the simple and fixed beams. When equal loads are applied to all spans simultaneously, the counter-balancing effect of the loads on both sides of a support restricts the movement of the cable tray at the support. The effect is similar to that of a fixed beam.

The end spans behave substantially like simple beams. When cable trays of identical design are compared, the continuous beam installation will typically have approximately half the deflection of a simple beam of the same span. The published load data in the NIEDAX cable tray catalog is based on the continuous beam analysis per IEC - Standard 61537. Therefore simple beam data should be used only for general comparison purposes.

Please note that NEMA Standards VE-1 limits the use of splice plates as follows:

Unspliced straight sections should be used on all simple spans and on end spans of continuous span runs. Straight section lengths should be equal to or greater than the span length to ensure not more than one splice between supports.

➔ CONCENTRATED LOADS

A concentrated static load represents a static weight applied at a single point between the side rails. Tap boxes, conduit attachments and long cable drops are just some of the many types of concentrated loads. When specified, these concentrated static loads may be converted to an equivalent, uniform load (W_e) by using the following formula:

$$W_e = 2 \times (\text{concentrated Static Load}) / \text{span length}$$

However, it should be noted that per NEMA Standard Publication VE1 cable tray is designed as a support for power or control cables, or both, and is not intended or designed to be a walk-way for personnel.

➔ POWER CABLING LOADS:

Power applications can create the heaviest loading. The heaviest cable combination found was for large diameter cables (i.e. steel armor, 600V, 4 conductor 750 kcmil). The cables weigh less than 3.8 lbs. per inch-width of cable tray. As power cables are installed in a single layer, the width of the cable affects the possible loading.

➔ DATA/COMMUNICATION CABLING LOADS:

Low voltage cables can be stacked as there are no heat generation problems. The NEC employs a calculation of the total cross sectional area of the cables not exceeding 50% of the fill area of the cable tray. As the cable fill area of the cable tray system affects the possible loading, both the loading depth and width of the systems must be considered. For this example 4UTP category 5 cable (O.D. = .21, .026 lbs./ft.) were used.

Mechanical Properties

ENVIRONMENTAL LOADS: WIND

Wind loads need to be determined for all outdoor cable tray installations. Most outdoor solutions are ladder type trays, therefore the most severe loading to be considered is impact pressure normal to the cable tray side rails. The impact pressure corresponding to several wind velocities are given below in Table 1.

V(mph)	P(lbs/ft ²)	V(mph)	P(lbs/ft ²)
15	0.58	85	18.5
20	1.02	90	20.7
25	1.60	95	23.1
30	2.30	100	25.6
35	3.13	105	28.2
40	4.09	110	30.9
45	5.18	115	33.8
50	6.39	120	36.8
55	7.73	125	40.0
60	9.21	130	43.3
65	10.80	135	46.6
70	12.50	140	50.1
75	14.40	145	53.8
80	16.40	150	57.6

V= Wind Velocity P= Impact Pressure

Note: These values are for an air density of 0.07651lbs/ft³ corresponding to a temperature of 16°C (60° F) and baro-metric pressure of 14.7 lbs/in².

Example Calculation:

Side load for 6" side rail with 100 mph wind (25.6 x 6)/12 = 12.8 lbs/ft

When covers are installed on outdoor cable trays, another factor to be considered is the aerodynamic effect which can produce a lift strong enough to separate a cover from a tray. Wind moving across a covered tray creates a positive pressure inside the tray and a negative pressure above the cover. This pressure difference can remove the cover from the tray.

ENVIRONMENTAL LOADS: ICE

Glaze ice is the most commonly seen form of ice build-up. It is the result of rain or drizzle freezing on impact with an exposed object. Generally, only the top surface (or the cover) and the wind bearing side of a cable tray system is significantly coated with ice. The maximum design load to be added due to ice should be calculated as follows:

- $L_i = (W \times T_i \times D_i) / 144$ where;
- L_i = Ice Load (lbs/linear foot)
- W = Cable Tray Width (inches)
- T = Maximum Ice Thickness (inches)
- D_i = Ice Density = 57 lbs/ft³

the maximum ice thickness will vary depending on location. A thickness of 1 /2" can be used as a conservative standard.

Example Calculation:

Ice Loads for 24" wide tray with 1 /2" thick ice; (24 x 0.5 x 57) / 144 = 4.75 lbs/ft

ENVIRONMENTAL LOADS: SNOW

Snow is measured by density and thickness. The density of snow varies almost as much as its thickness. The additional design load from snowfall should be determined using the building codes which apply for each installation.



Bonding and Grounding

➔ The National Electrical Code states that all metallic cable trays supporting electrical conductors shall be properly bonded (NEC 250.90 and NEC 250.96) and grounded (NEC 392.7).

- Definition: **Bonding** grants electrical continuity of separate sections (of cable tray).
- Definition: **Grounding** grants a low impedance (direct) connection to earth.
- Standards: According to NEC a properly bonded system can be used as an EGC (equipment grounding conductor) within the limits of NEC Table 392.7(B), i.e. the cable tray can replace the green (ground) wire. This standard is valid only in the US!

Maximum Fuse / Circuit Breaker Ampere Rating	60 A	100 A	200 A	400 A	600 A
Minimum Cross Sectional Area of Steel	0.20 sq in	0.40 sq in	0.70 sq in	1.00 sq in	1.5 sq in
	129 mm ²	258 mm ²	452 mm ²	645 mm ²	968 mm ²

- Standards: In Canada (and almost the rest of the world) cable trays can't be used as a grounding conductor.
- This difference in electrical standards leads to two different UL classifications:



- The C-UL-US classified trays can be used as EGC in the US, the C-UL trays not. But both labels grant proper bonding according to NEC and CSA as long as UL rated splices are used.

WARNING! Do Not Use As A Walkway, Ladder, Or Support For Personnel.

Use Only As A Mechanical Support For Cables, Tubing and Raceways.

<p>Catalog Number: <small>(and description)</small></p> <p>WRLX 150.200/3 Straight Sections</p>	<p>ventilated 08/08/2007</p>	 <small>Complete with system</small>
<p>Minimum Area: Load Class:</p> <p>1.0 sq. in. E 320 kg/m 3 meter span</p>		<p><small>Asbacher Str. 141 D - 53545 Linz am Rhein +49 (2644) 5806-0</small></p>

REFERENCE FILE # E233344

This product is classified by Underwriters Laboratories, Inc. as to its suitability as an equipment grounding conductor only. **9JA9**

FB3M

Installation Instructions

➔ INSTALLATION

Attention Cable Tray Installers — Cable tray system design shall comply with NEC Article 392, NEMA VE 1, IEC 61537 and shall follow safe work practices as described in NFPA 70E and NEMA VE 2.

The instructions and information contained here-in are not intended to cover all details or variations in cable tray systems, nor do they account for every possible installation scenario.

It is recommended that the installation work described be performed by qualified personnel, preferably a certified electrical contractor, familiar with standard electrical construction practices, electrical equipment, and safety of electrical wiring systems.

➔ TYPE OF CABLE

According to NEC Article 318, multiconductor tray cable may be installed in any standard cable tray bottom type. Single conductor tray cable may be installed only in ladder or ventilated bottom cable trays (not solid bottom). Solid bottom cable trays are not allowed to be installed in Class II, Division 2 locations (1999 NEC Section 502-4(b)). In general, small, highly flexible cables should be installed in solid bottom, vented bottom cable trays. Sensitive cables (e.g. fiberoptic) are typically installed in flat, solid bottom cable trays, instead of corrugated trough bottoms. Larger, less flexible cables are typically installed in ladder type cable trays having 12" rung spacing.

➔ SUPPORT INSTALLATION

Caution! Supports for cable trays should provide strength and working load capabilities sufficient to meet the load requirement of the cable tray wiring system. Consideration should be given to the loads associated with future cable additions or any other additional loads applied to the cable tray system or the cable trays support system.

There are many different ways of supporting cable trays. The most common approach in the US is to use threaded rod and a rail to build a trapeze hanger. Other systems like ceiling hangers with cantilever brackets will allow cables to be laid into the tray instead of being pulled through.

➔ STRAIGHT SECTION POSITION

After the supports are in place, the installation of the cable tray can begin at any place that is convenient. It is not necessary to start at one end of the run. It is ideal to lay out the system so that splice joints fall between the support and the quarter point. This maximizes the rigidity of the cable tray.

To begin, place a straight section across two supports so that the ends of the section are not directly on the support. If the support span is equal to the length of the straight sections, bolt two pieces together for this step. As a general practice, avoid placing splice plates over supports or at mid-span.

➔ FIELD MODIFICATIONS

Cable Tray can be adapted (cut to spec in field situations). These field modifications should be made by qualified personnel only. (preferably a certified electrical contractor)

➔ BARRIER REQUIREMENTS

Barrier strips are used to separate cable systems, such as when cables above and below 600 volts per NEC 318-6(f) are installed in the same cable tray. However, when MC type cables rated for over 600 volts are installed in the same cable tray with cables rated 600 volts or less, no barriers are required. The barriers should be made of the same material type as the cable tray. When ordering the barrier, the height must match the loading depth of the cable tray into which it is being installed.



FUTURE EXPANSION REQUIREMENTS

One of the many features of cable tray is the ease of adding cables to an existing system. Future expansion should always be considered when selecting a cable tray, and allowance should be made for additional fill area and load capacity. A minimum of 50% expansion allowance is recommended.

SPACE LIMITATIONS

Any obstacles which could interfere with a cable tray installation should be considered when selecting a cable tray width and height. Adequate clearances should be allowed for installation of supports and for cable accessibility. Note: The overall cable tray dimensions typically exceed the nominal tray width and loading depth.

Fitting Radius

CABLE FLEXIBILITY

The proper bend radius for cable tray fittings is usually determined by the bend radius and stiffness of the tray cables to be installed. Typically, the tray cable manufacturer will recommend a minimum bend allowance for each cable. The fitting radius should be equal to or larger than the minimum bend radius of the largest cable which may ever be installed. When several cables are to be placed in the same cable tray, a larger bend radius may be desirable to ease cable installation.

Space Limitations

The overall dimensions for a cable tray fitting will increase as the bend radius increases. Size and cost make the smallest acceptable fitting radius most desirable. When large radius fittings are required, the system layout must be designed to allow for adequate space.

Fittings Installation

RECOMMENDED SUPPORT LOCATIONS FOR FITTINGS

The following are recommended support diagrams to serve as guidelines for installing Steel Cable Tray support systems in the field. The information is intended to provide the installer some practical assistance when estimating the amounts of necessary supports and to help in identifying support locations for various field conditions.

However, it does not cover every situation that may arise when installing the product. It may be possible to install narrow trays with lighter loads and fewer supports. Wider trays with heavier loading, trays with long radii, or those with multiple side cuts may require additional support to avoid unwanted deflection.

HORIZONTAL ELBOW SUPPORT

Supports for horizontal cable tray fittings should be placed within 2ft. (600 mm) of each fitting extremity, and as follows:

- 90° supports at the 45° point of arc.
- 60° supports at the 30° point of arc.
- 45° supports at the 22-1/2° point of arc (except for the 12 in. [300 mm] radii).
- 30° supports at the 15° point of arc (except for the 12 in. [300 mm] radii).

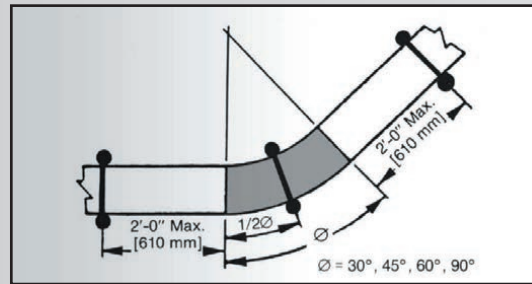

HORIZONTAL TEE SUPPORT

Place horizontal tee supports within 2 ft. (600 mm) of each of the three openings connected to other cable tray items for the 12 in. (300 mm) radius. On all other radii, at least one additional support should be placed under each side rail at the horizontal tee, preferably as shown.

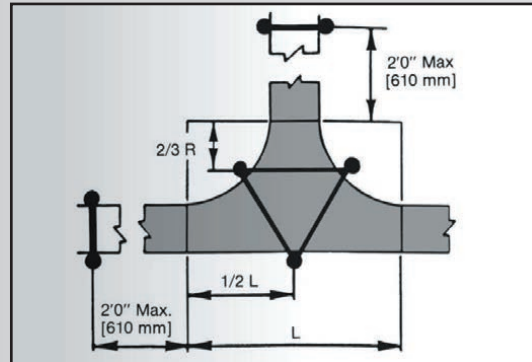

Other Factors To Consider

➔ HORIZONTAL Y SUPPORT

Place horizontal Y supports within 2 ft. (600 mm) of each of the three openings connected to other cable tray items, and at 22-1/2° point of the arc adjacent to the side branch.

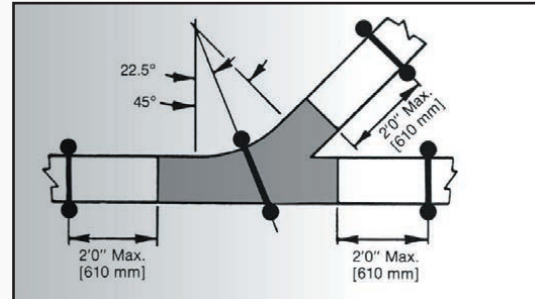

➔ HORIZONTAL CROSS SUPPORT

Place horizontal cross support within 2 ft. (600 mm) of each of the four openings connected to other cable tray items for the 12 in. (300 mm) radius. On all other radii, at least one additional support should be placed under each side rail of the horizontal cross, preferably as shown.

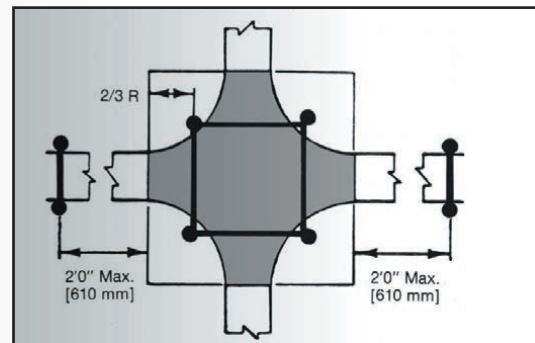

➔ VERTICAL CABLE TRAY ELBOW

Vertical cable tray elbows at the top of runs should be supported at each end. At the bottom of runs, they should be supported at the top of the elbow and within 2 ft. (600 mm) of the lower extremity of the elbows.

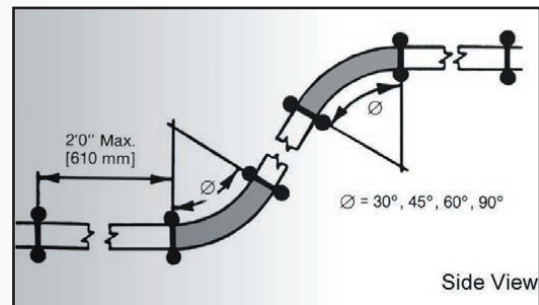

➔ REDUCER SUPPORT

Place reducer supports within 2 ft. (600 mm) of each fitting extremity.

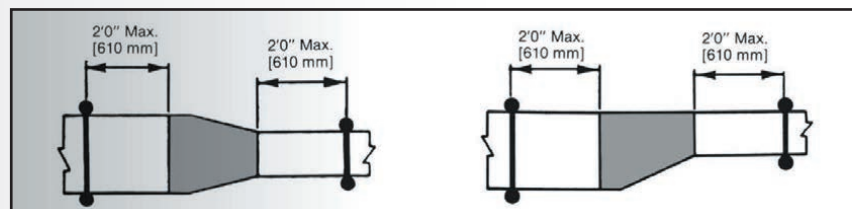

GENERAL INFORMATION

Hole Patterns

RLVC 60...

100 mm

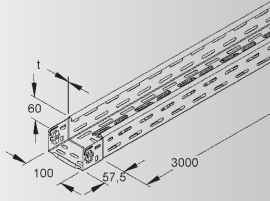

Siderail Pattern

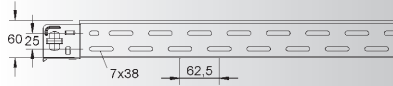

Bottom Pattern

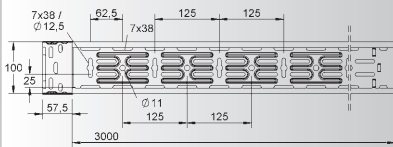

200 mm

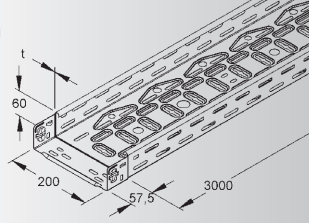

Siderail Pattern

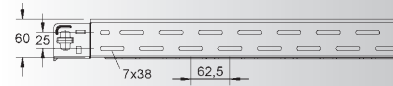

Bottom Pattern

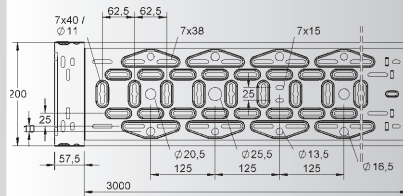

300 mm

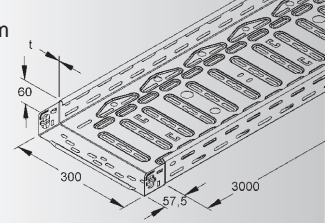

Siderail Pattern



Bottom Pattern

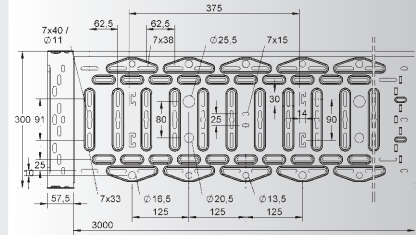

400 mm

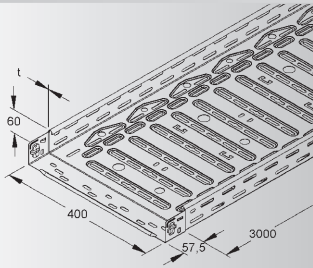

Siderail Pattern



Bottom Pattern

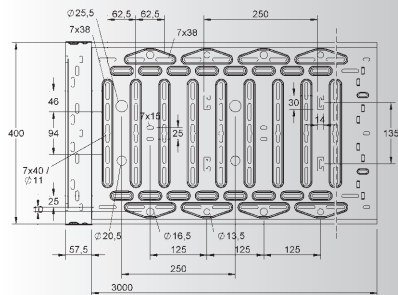

500 mm

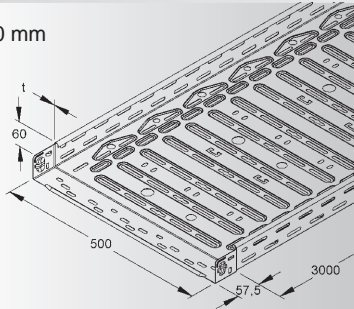

Siderail Pattern

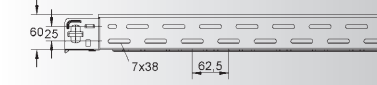

Bottom Pattern

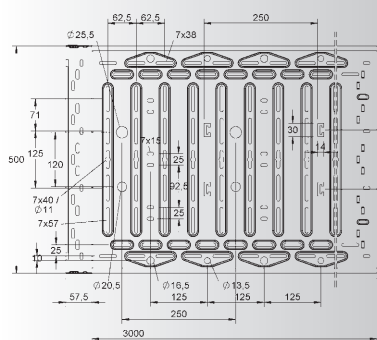

600 mm

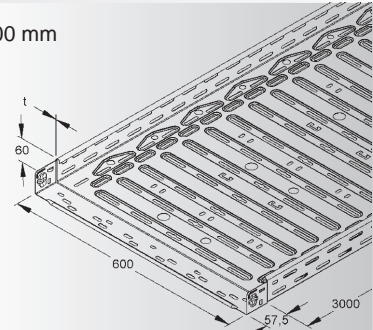

Siderail Pattern

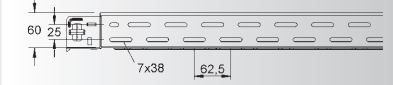

Bottom Pattern

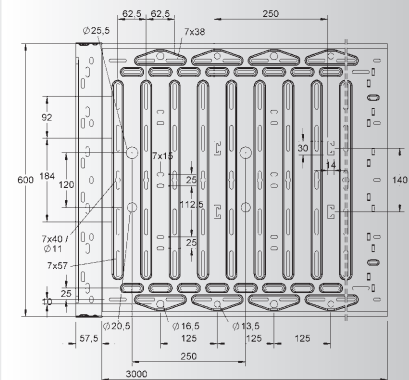

Hole Patterns

RLCI 60...

100 mm

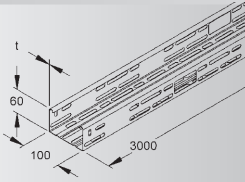

Siderail Pattern

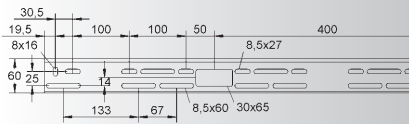

Bottom Pattern

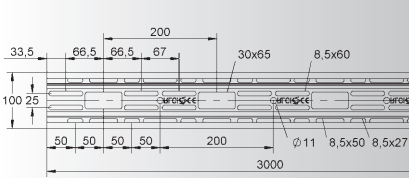

200 mm

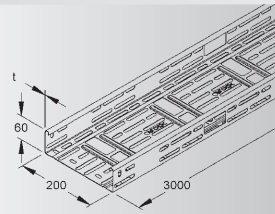

Siderail Pattern

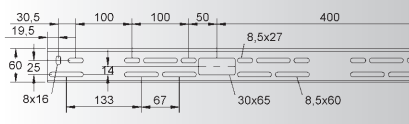

Bottom Pattern

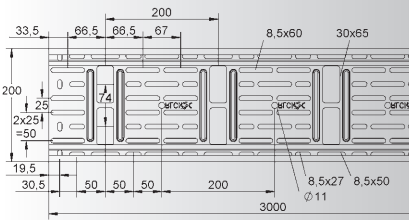

300 mm

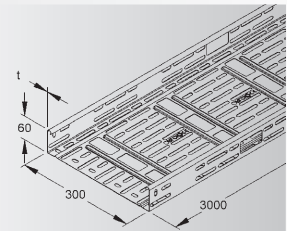

Siderail Pattern

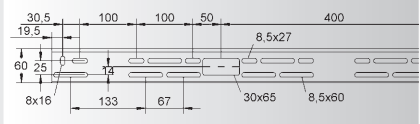

Bottom Pattern

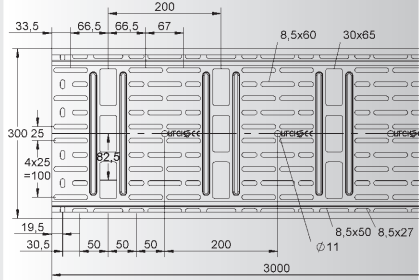

400 mm

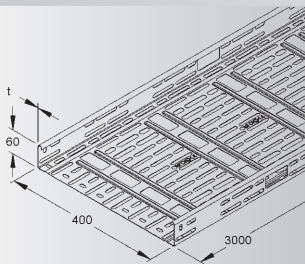

Siderail Pattern

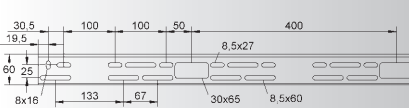

Bottom Pattern

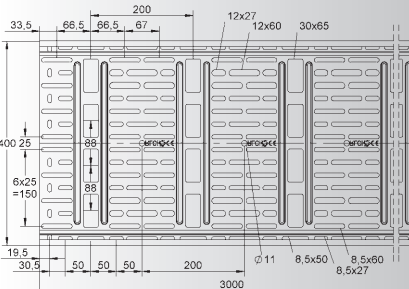

500 mm

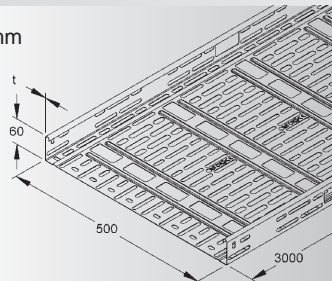

Siderail Pattern

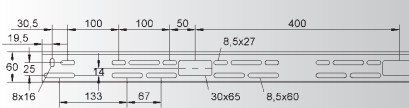

Bottom Pattern

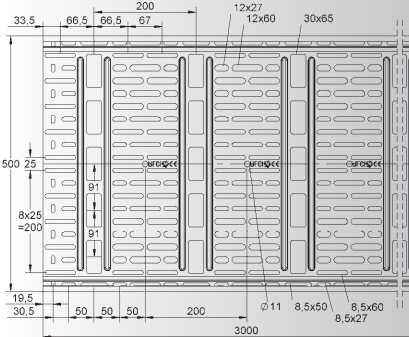

600 mm

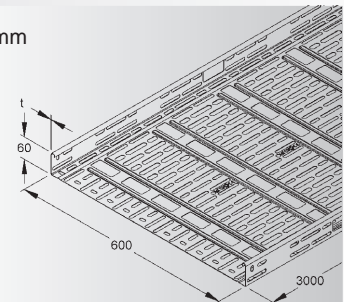

Siderail Pattern

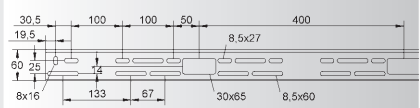

Bottom Pattern

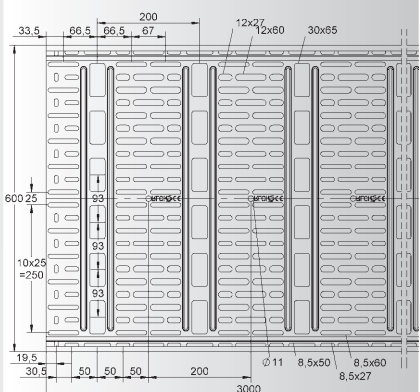

GENERAL INFORMATION

Hole Patterns

RSV 110...

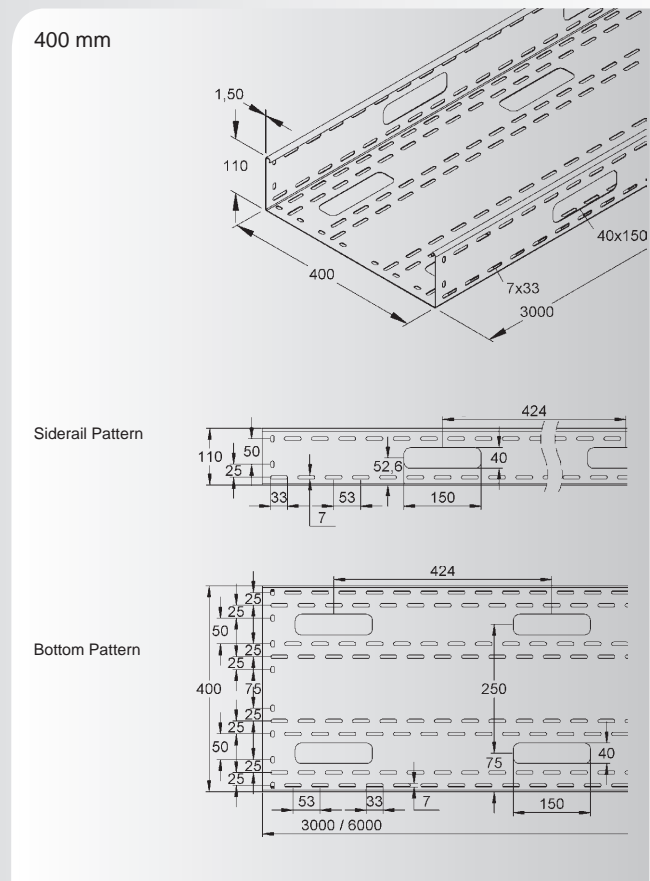
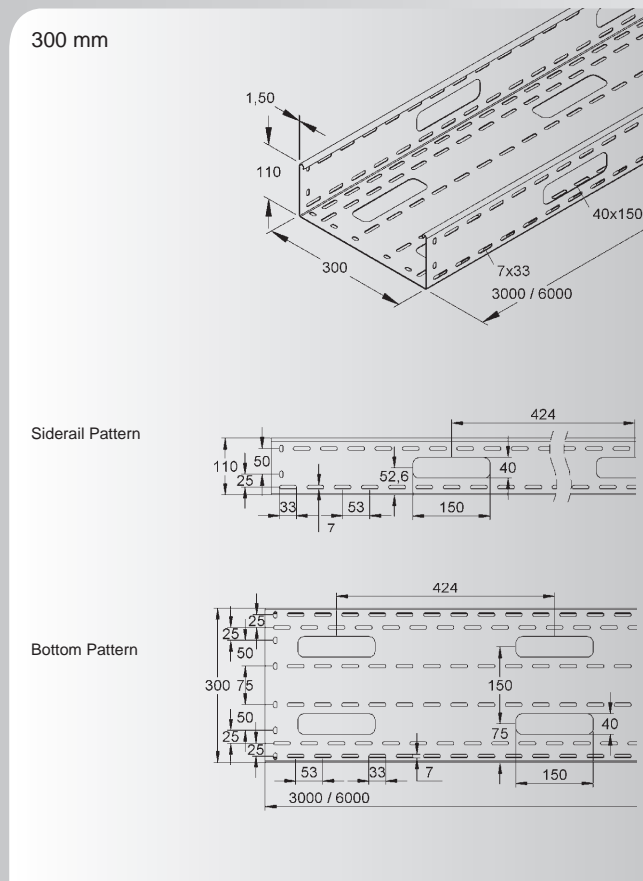
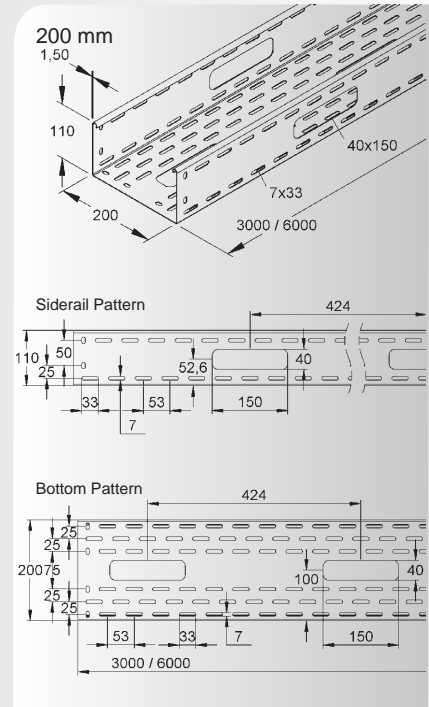
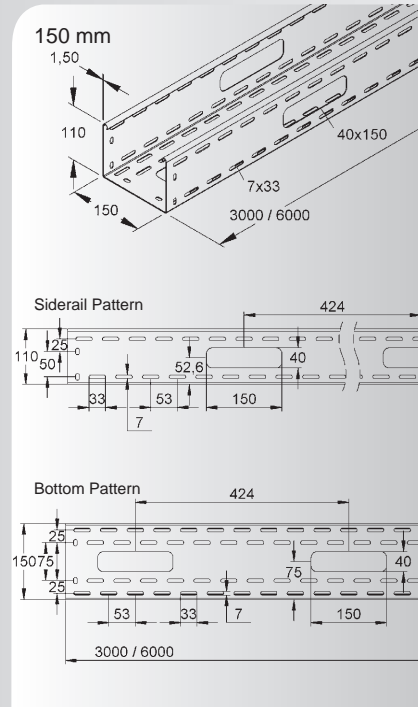
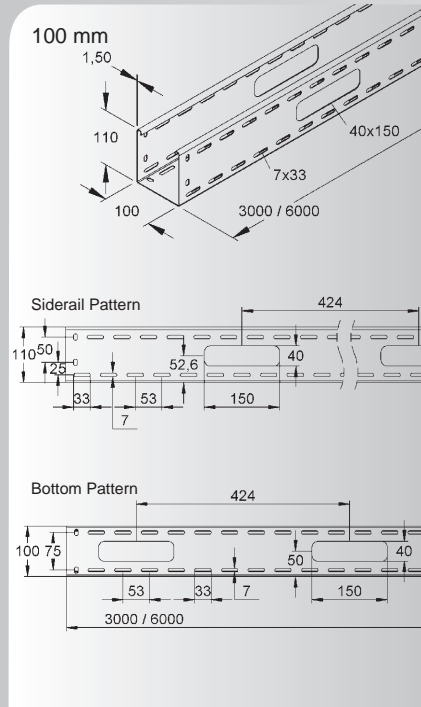

Installation Instructions

PKS...

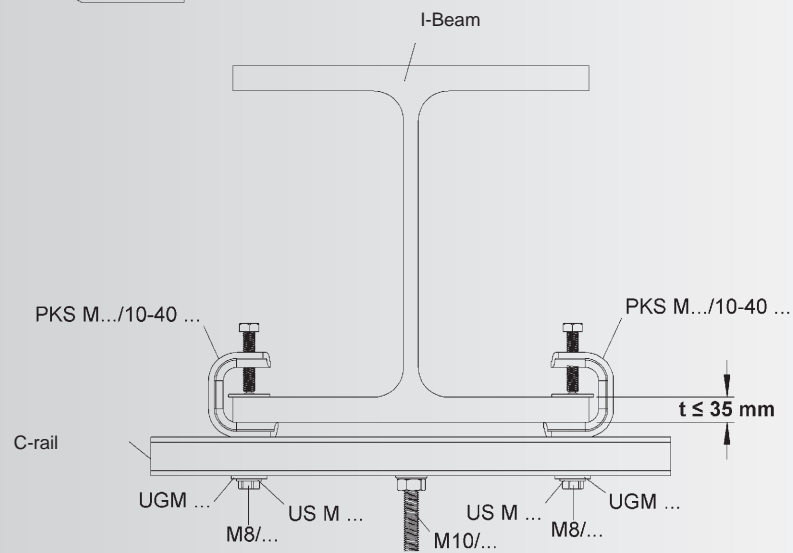
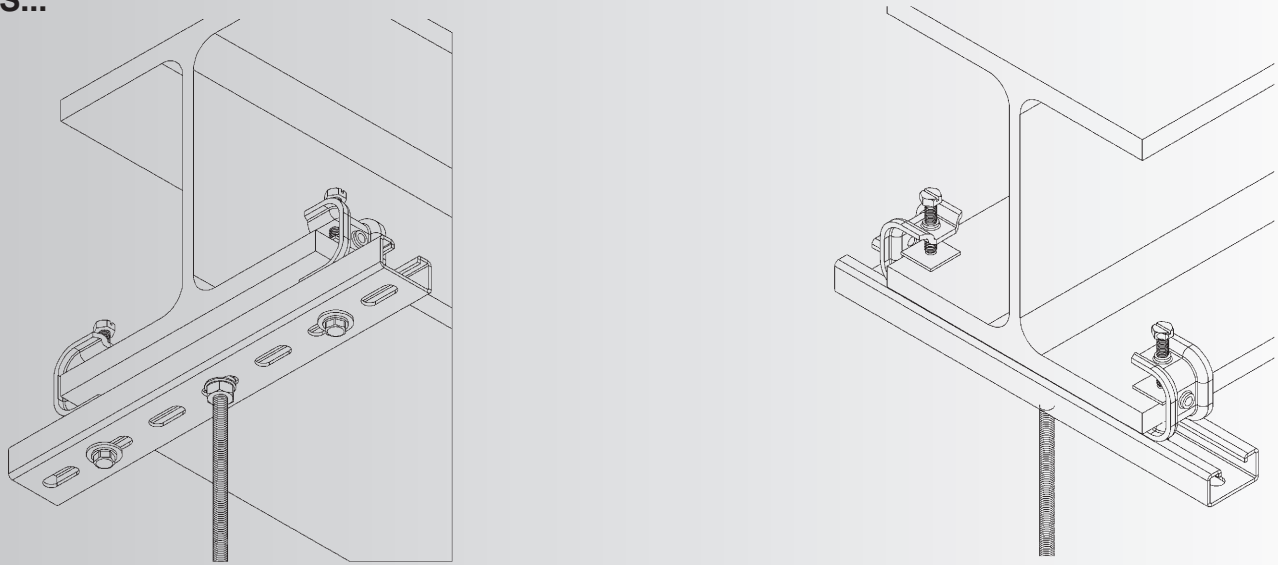

TKM...

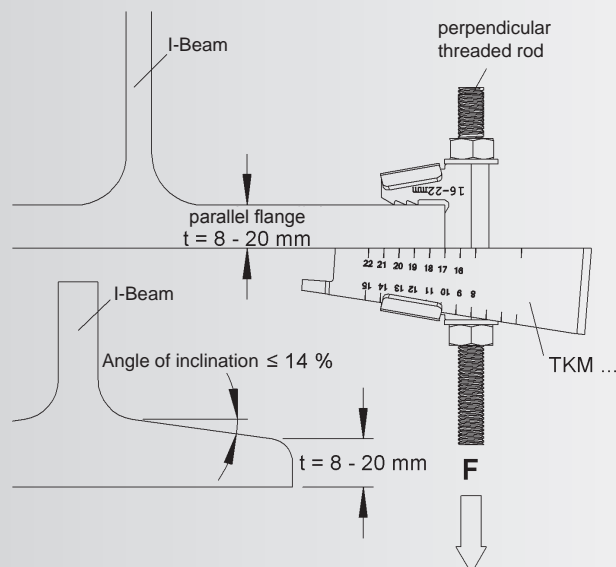

GENERAL INFORMATION

Installation Instructions

Typical clamping installation of cable tray to steel beams.

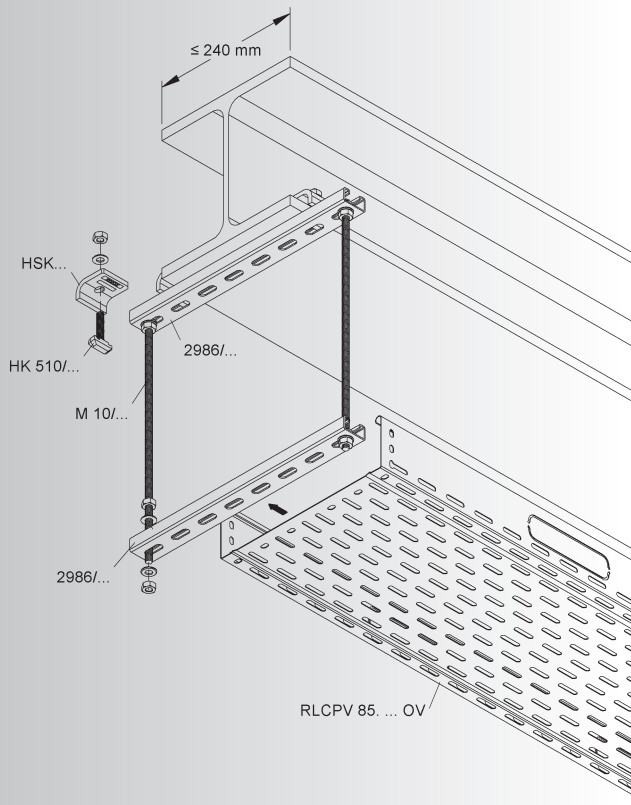

Typical clamping installation of cable tray to steel beams.

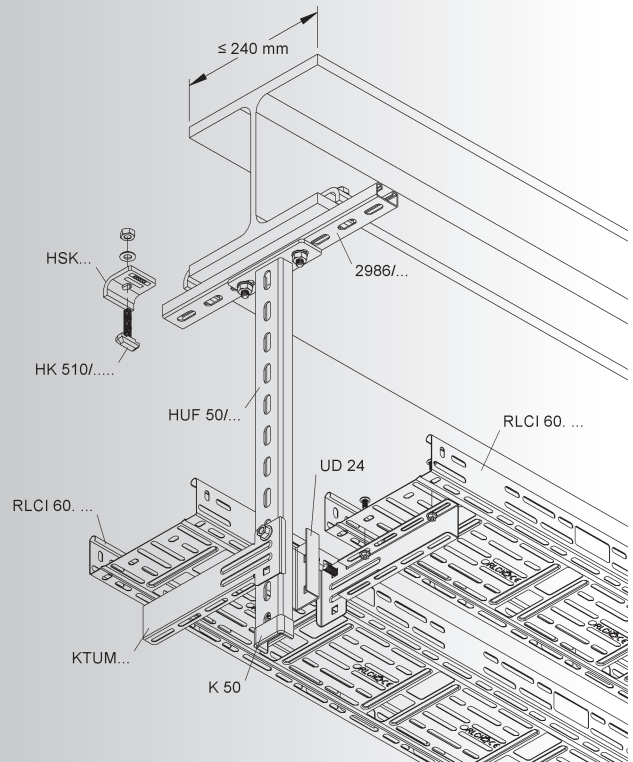

Typical clamping installation of longspan tray parallel to steel beams.

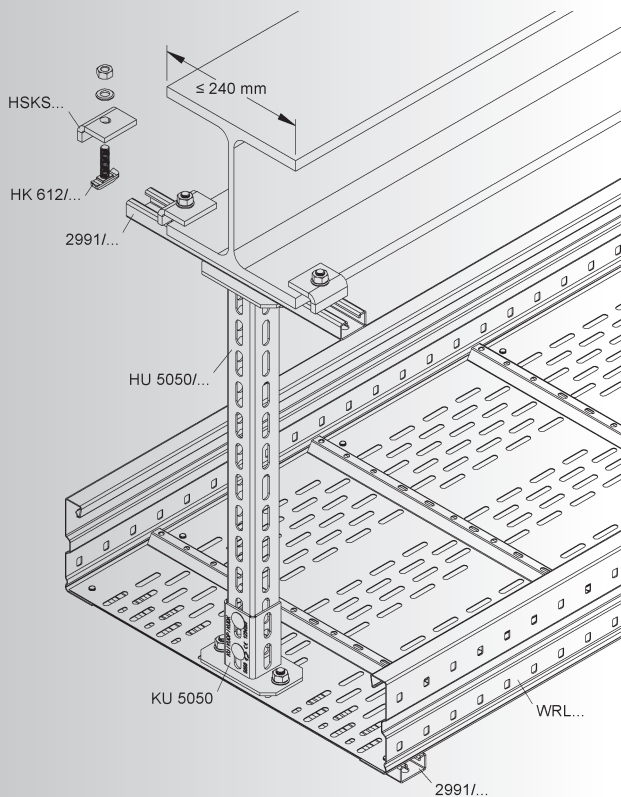

Typical clamping installation of cable tray parallel to steel beams.

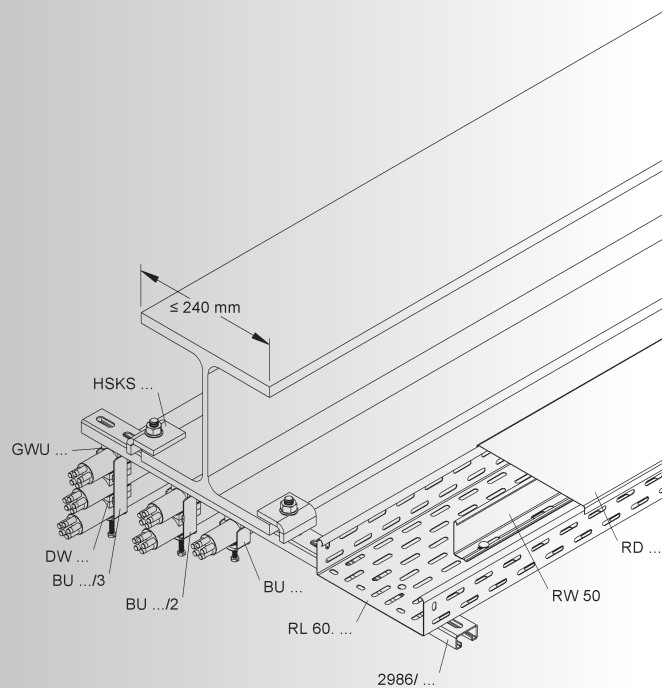

Installation Instructions

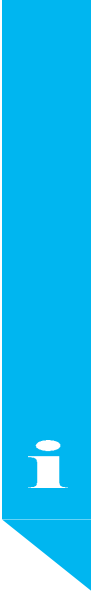
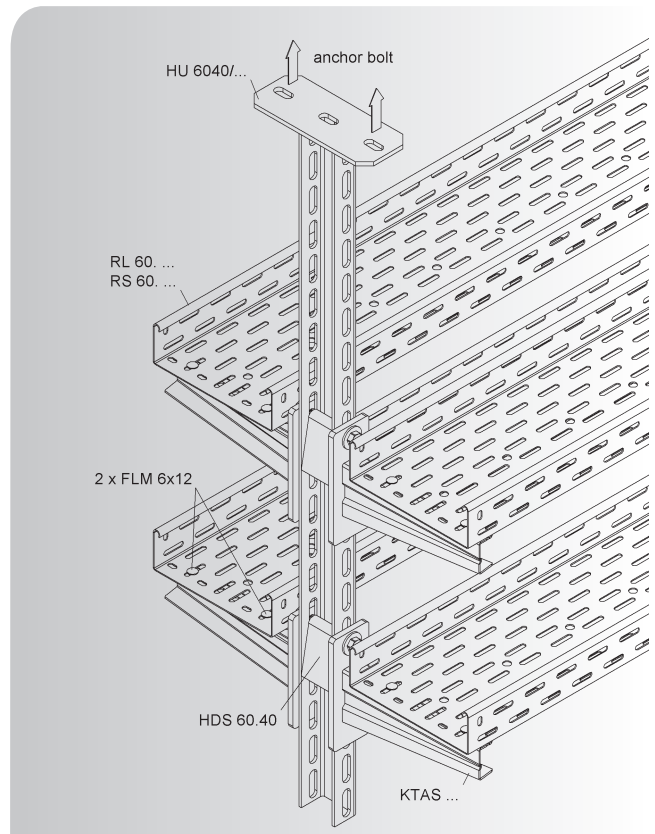
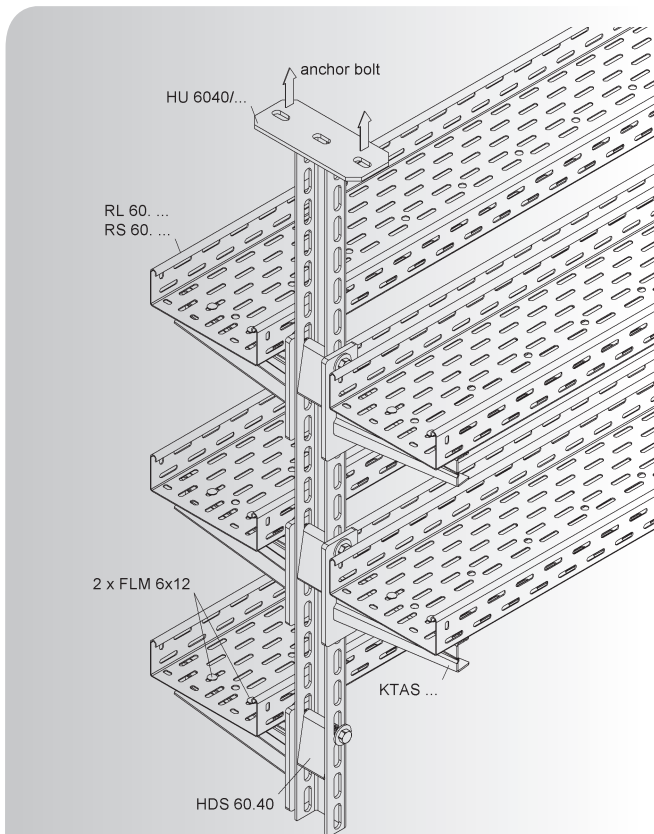
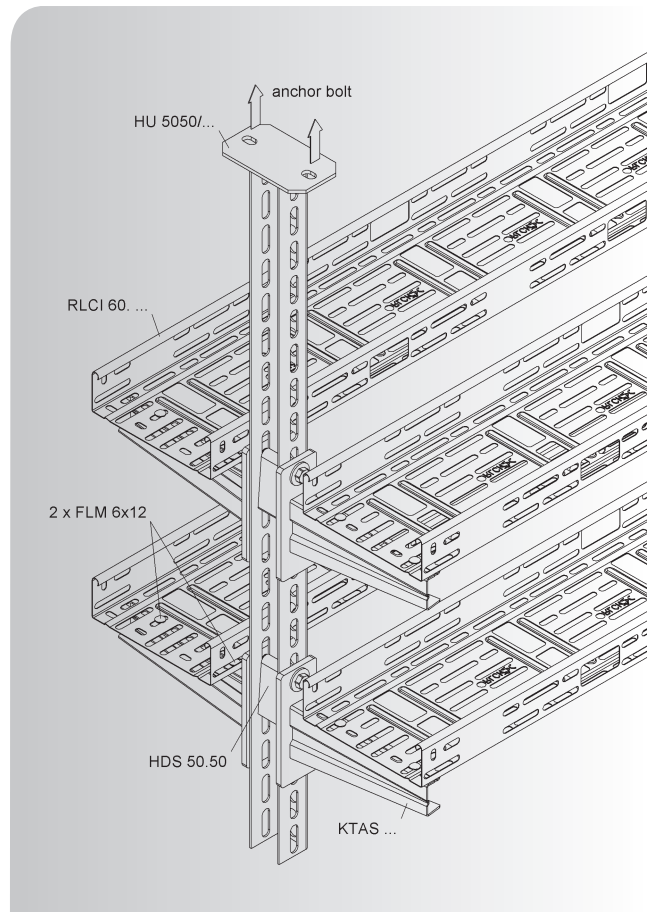
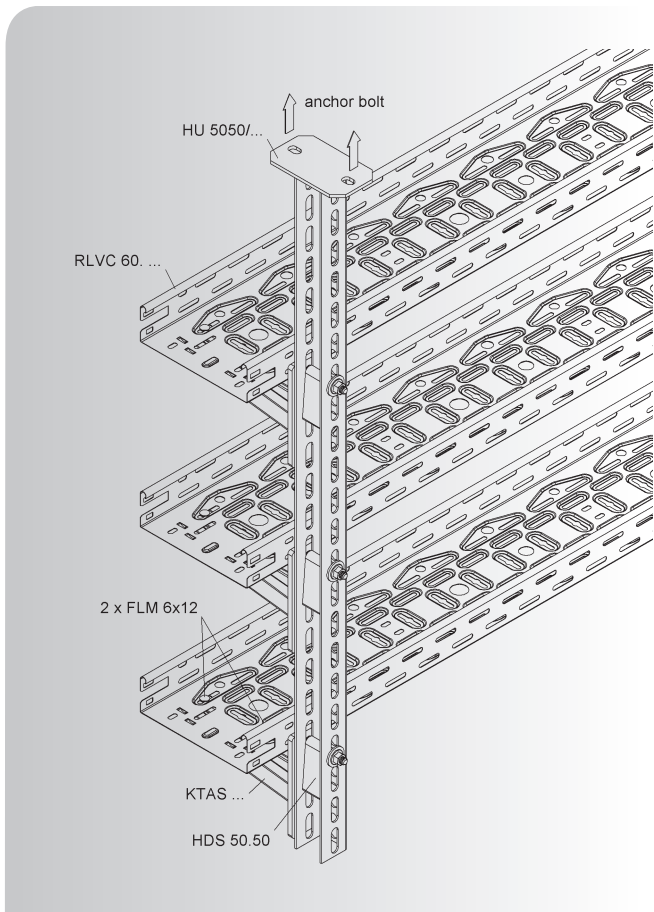

GENERAL INFORMATION

Installation Instructions

MTC... Wire Mesh Tray with Snap Connector

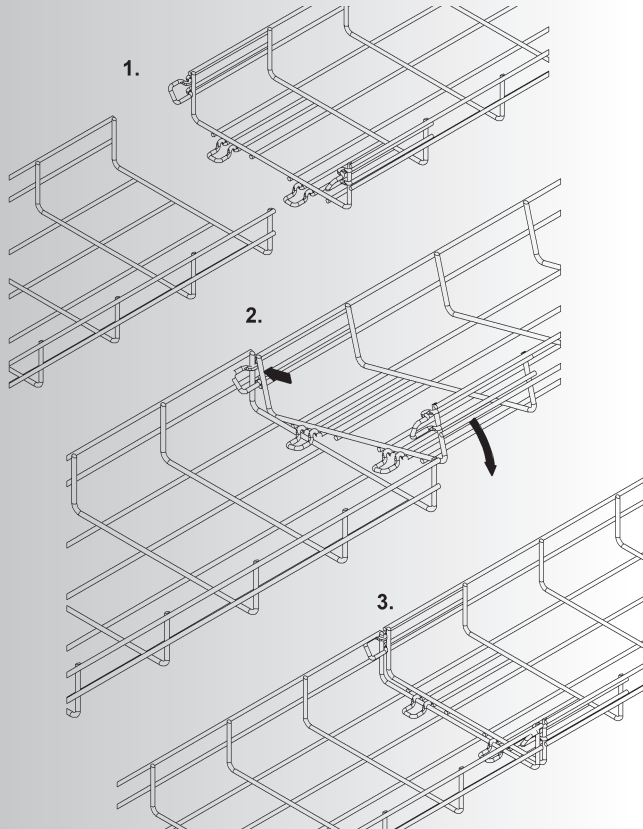

Splice Kit for and MTC... Wire Mesh Tray

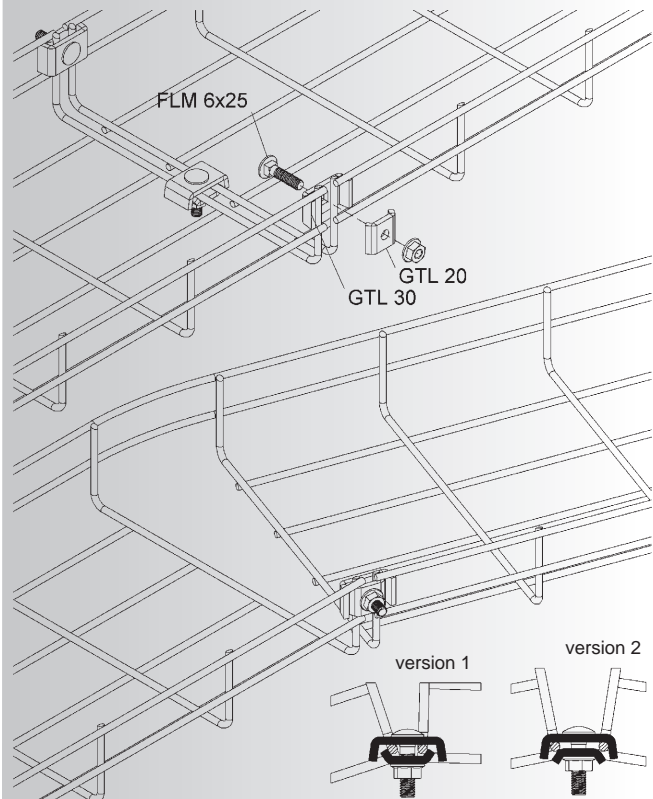

Horizontal 90° Splice Plate for GRS... and MTC... Wire Mesh Tray

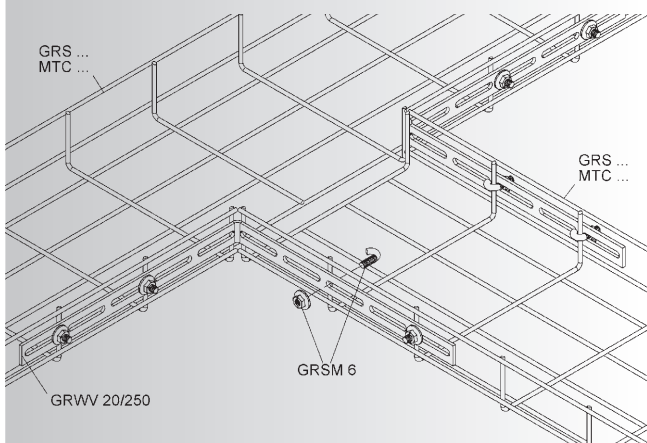

Flexible Vertical Splice Plate for GR..., GRS... and MTC... Wire Mesh Tray

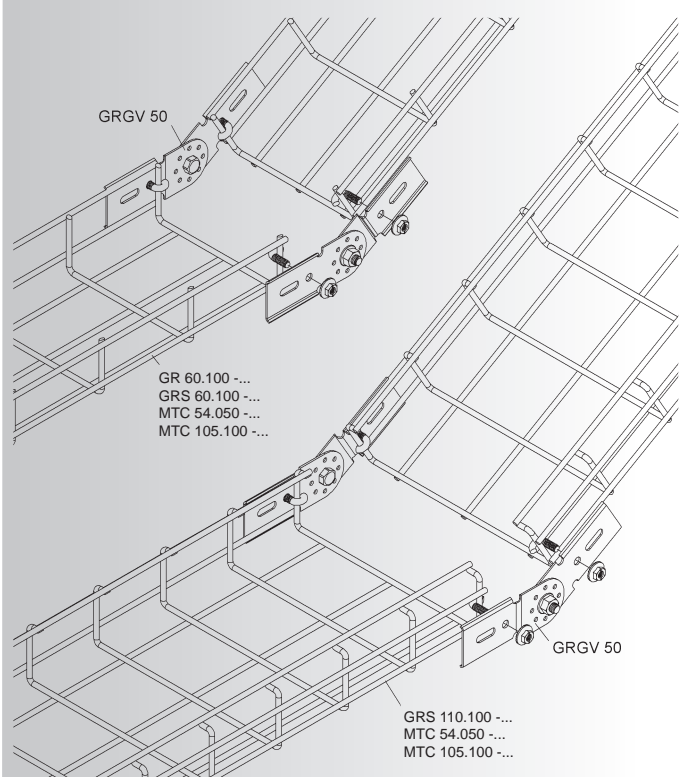

Installation Instructions

Wall Mount Bracket for GR..., GRS... and MTC... Wire Mesh Tray

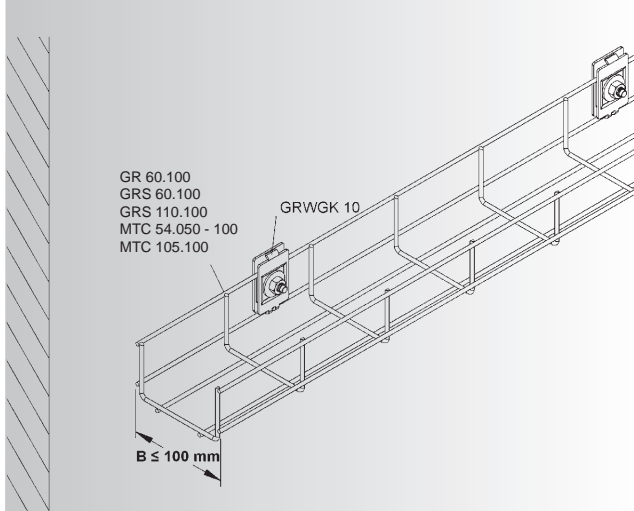

L-Bracket for GRS... and MTC... Wire Mesh Tray

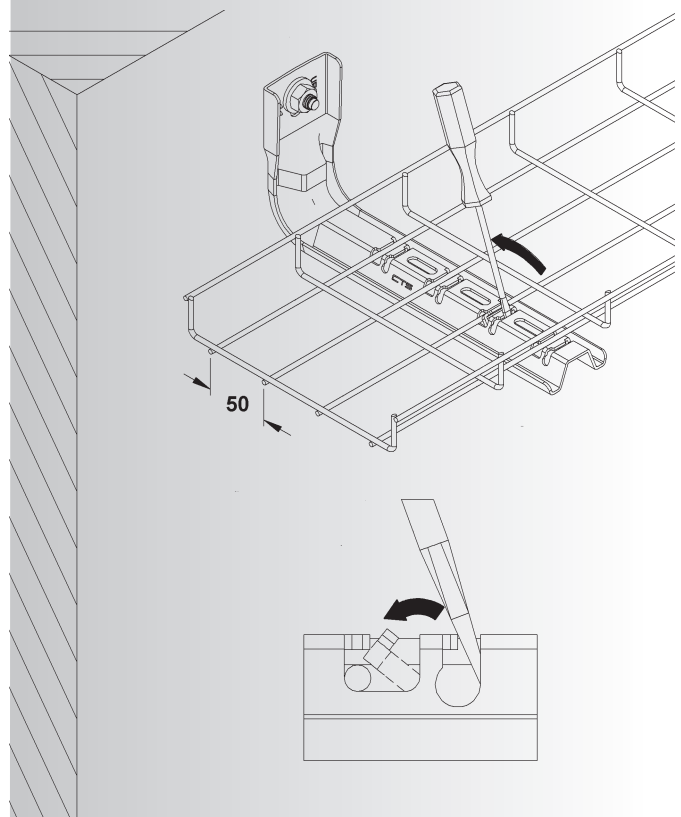

C-Hanger MTC... Wire Mesh Tray

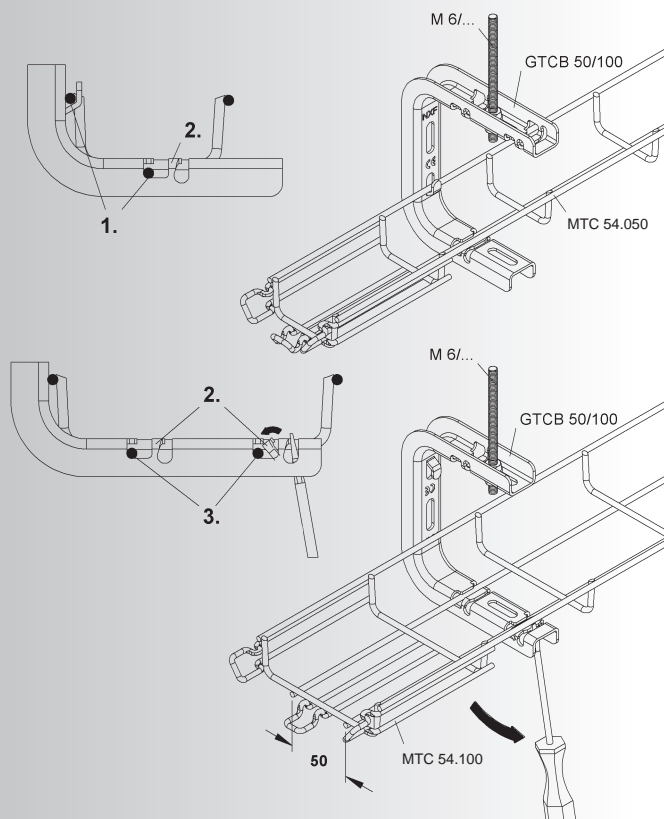

Center Hanger for MTC... Wire Mesh Tray

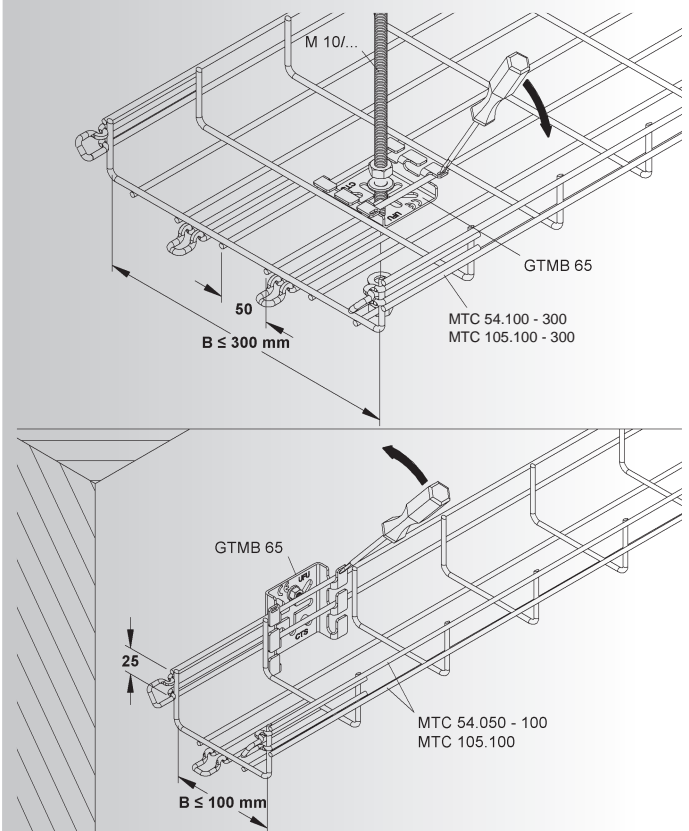

GENERAL INFORMATION

Installation Instructions

Center Hanger for MTC... Wire Mesh Tray

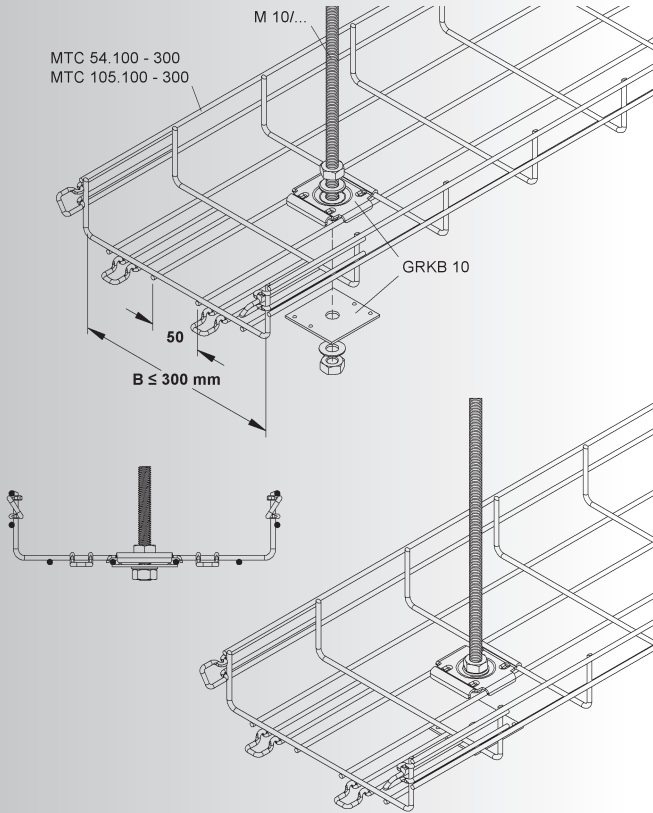

Trapeze Hanger for MTC... Wire Mesh Tray

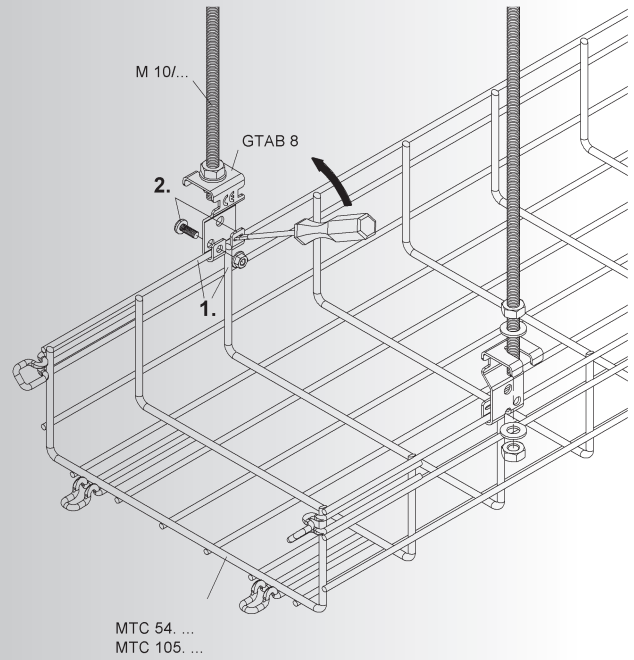

Cable Drop Outs for GR..., GRS... and MTC... Wire Mesh Tray

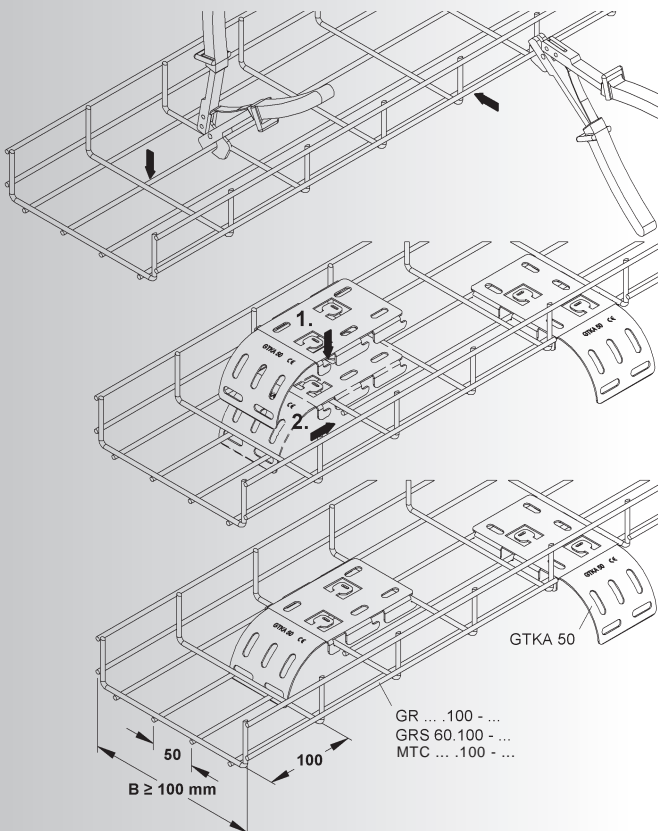

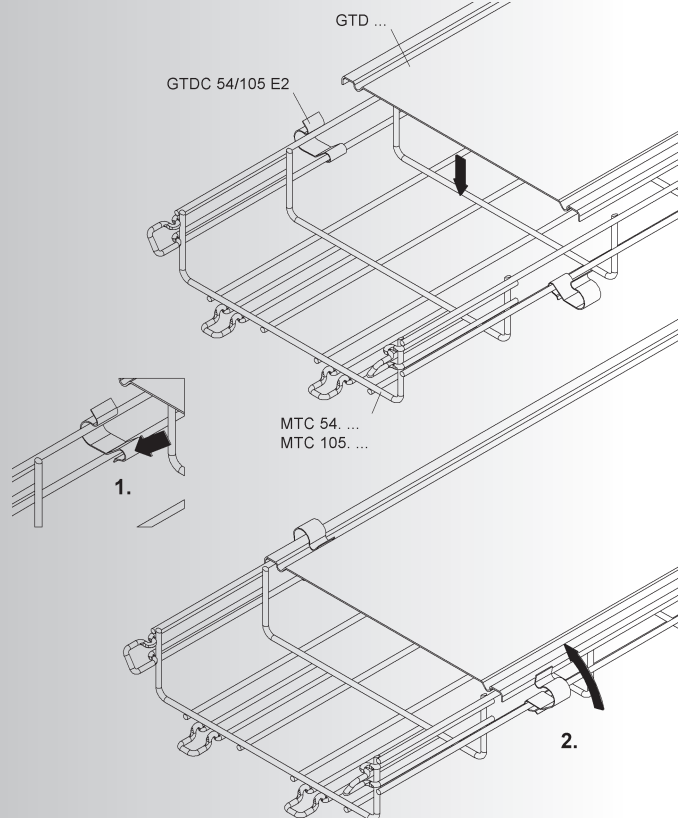

Covers for MTC... Wire Mesh Tray

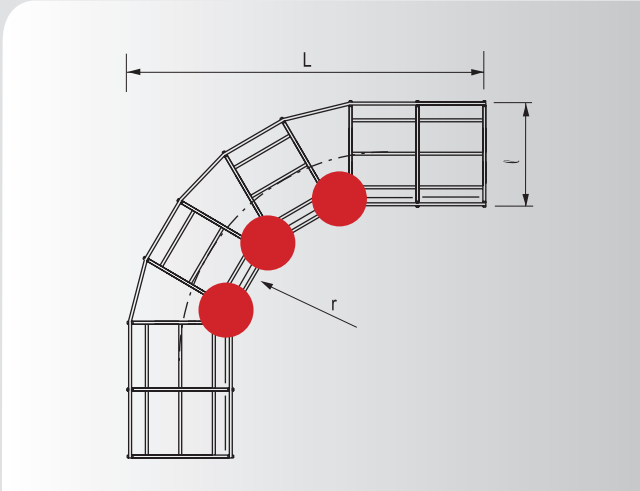
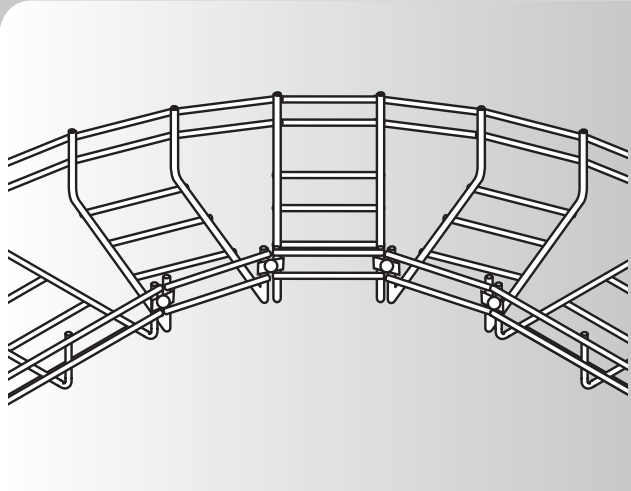

How to Build Wire Mesh Tray Fittings

Large Radius Elbows



 stands for (GTL 20 + GTL 30 + FLM 6x20)

 stands for 1 x GTVL 300 + 4 GRHKM 6x15



W=100 mm 1 x GTVL 300 + 4 GRHKM 6x15



W=150 mm 2 x (GTL 20 + GTL 30 + FLM 6x20)
and 1 x GTVL 300 + 4 GRHKM 6x15



W=200 mm 2 x (GTL 20 + GTL 30 + FLM 6x20)
and 1 x GTVL 300 + 4 GRHKM 6x15



W=300 mm 4 x (GTL 20 + GTL 30 + FLM 6x20)
and 1 x GTVL 300 + 4 GRHKM 6x15



W=450 mm 6 x (GTL 20 + GTL 30 + FLM 6x20)
and 1 x GTVL 300 + 4 GRHKM 6x15





W=600 mm 8 x (GTL 20 + GTL 30 + FLM 6x20)
and 1 x GTVL 300 + 4 GRHKM 6x15

GENERAL INFORMATION

How to Build Wire Mesh Tray Fittings

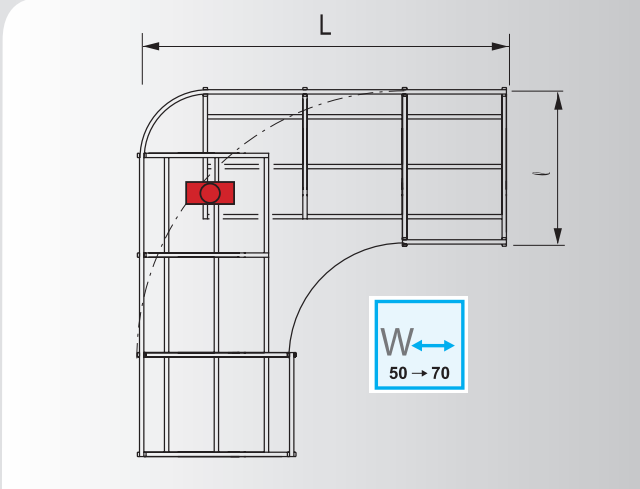
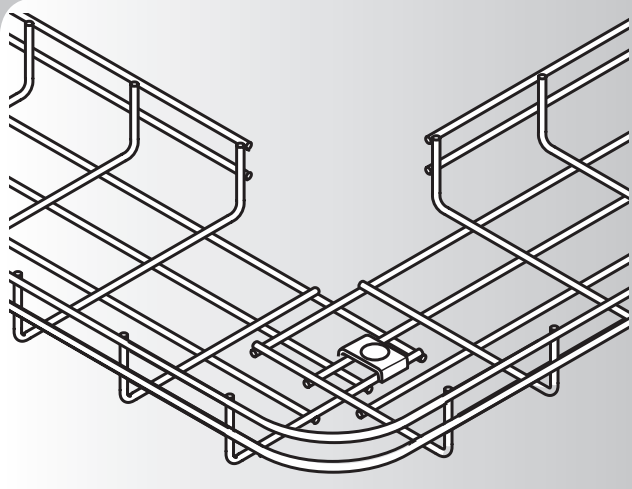
Small Radius Elbows



 stands for (GTL 20 + GTL 30 + FLM 6x20)



W=100 mm
1 x (GTL 20 + GTL 30 + FLM 6x20)

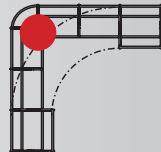

W=150 mm
1 x (GTL 20 + GTL 30 + FLM 6x20)

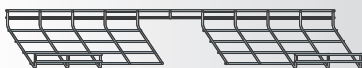
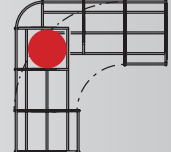

W=200 mm
1 x (GTL 20 + GTL 30 + FLM 6x20)

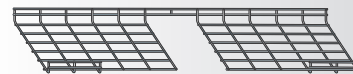
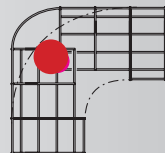

W=300 mm
1 x (GTL 20 + GTL 30 + FLM 6x20)

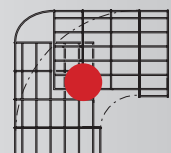

W=450 mm
1 x (GTL 20 + GTL 30 + FLM 6x20)

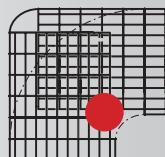

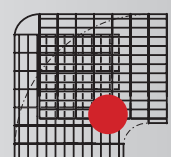

W=600 mm
1 x (GTL 20 + GTL 30 + FLM 6x20)

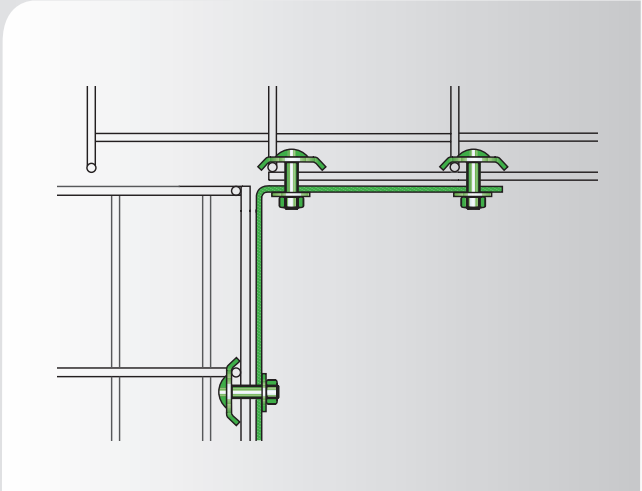
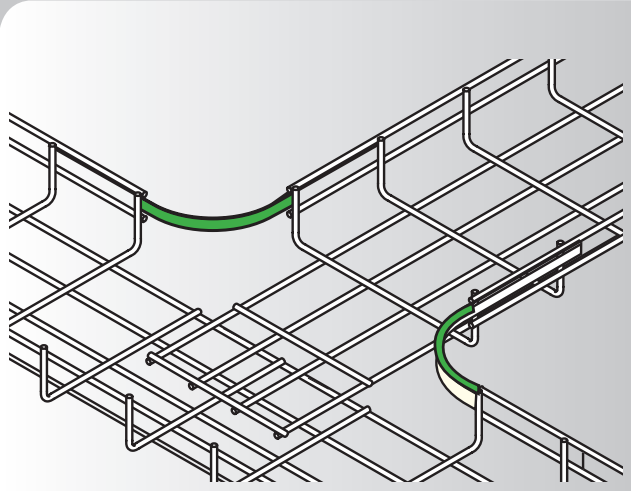

How to Build Wire Mesh Tray Fittings

Angular Tees



 stands for GRHKM 6x15 or GRSM 6 fastener location



W=100 mm
8 x GRHKM 6x15 and 2 x GRVV 20/250



W=150 mm
8 x GRHKM 6x15 and 2 x GRVV 20/250

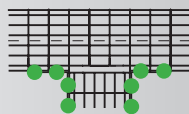
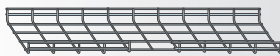

W=200 mm
8 x GRHKM 6x15 and 2 x GRVV 20/250

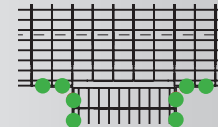

W=300 mm
8 x GRHKM 6x15 and 2 x GRVV 20/250

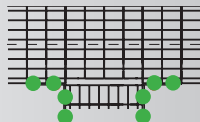

W=450 mm
8 x GRHKM 6x15 and 2 x GRVV 20/250

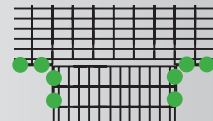

W=600 mm
8 x GRHKM 6x15 and 2 x GRVV 20/250

GENERAL INFORMATION

Installation Instructions

How to install/deinstall the cover clamp RDHF 9 E2

Install

1. Put RDHF 9 E2 into position at the flange of the cover

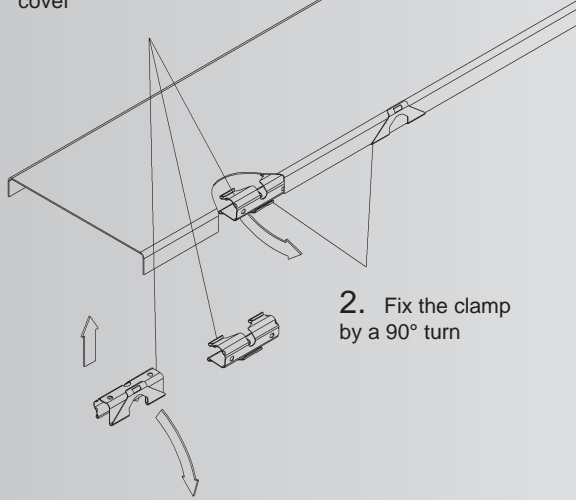

3. Cover clamps can be latched onto the cover anywhere

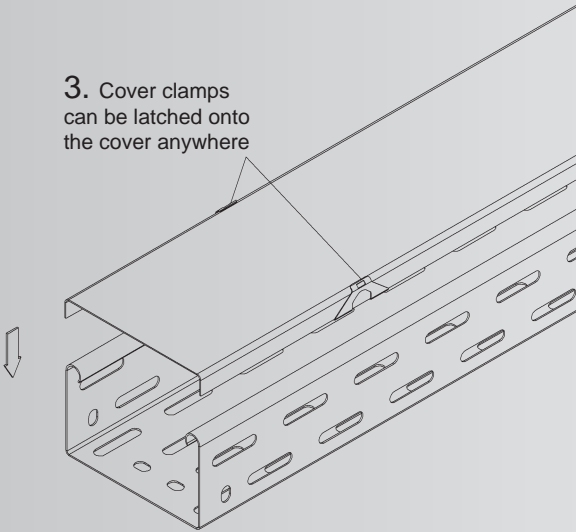

Deinstall

1. strip off cover (clamp stays on cover)

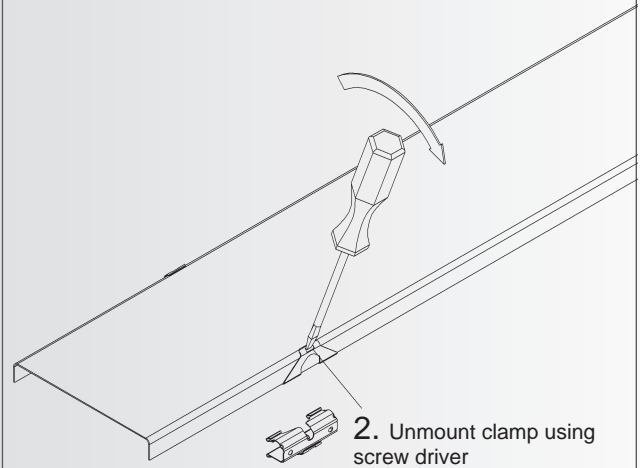
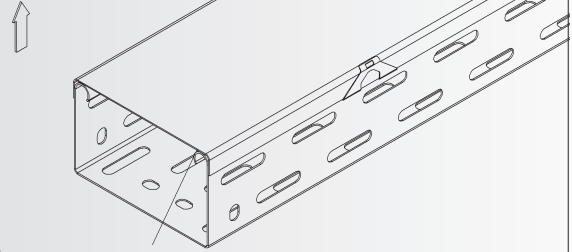

Cover clamp can be reused if removed properly.



Installation Instructions

RW...

Installing barrier strips to wire mesh or cable tray

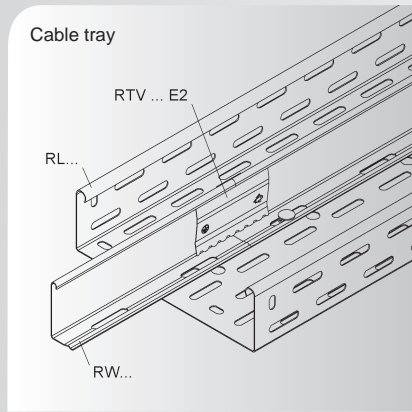
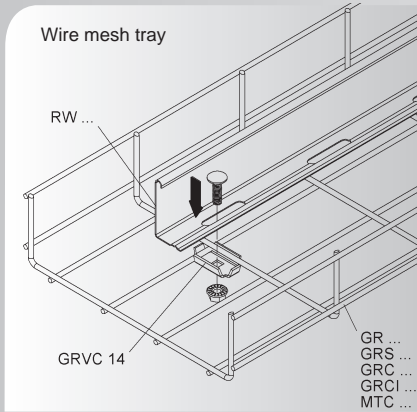

RTV...

Installing barrier strip splice plates

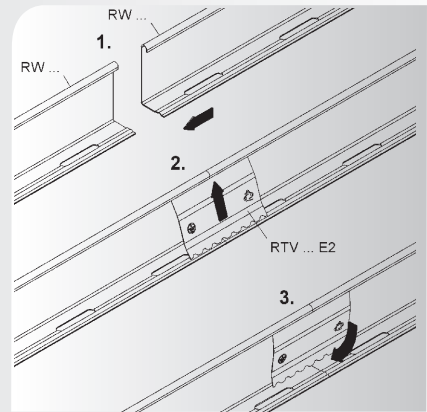

Installing barrier strips to cable ladders in **S** or **F** finish

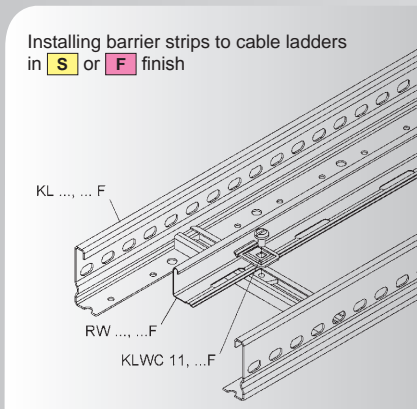

Stainless steel cable ladders

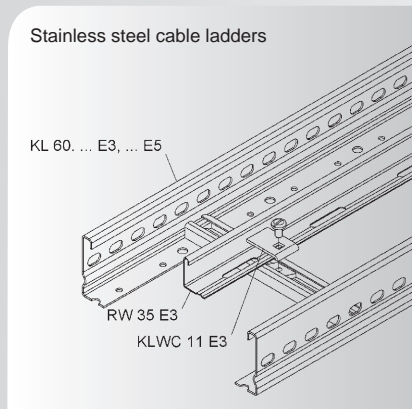

Installing barrier strips to long span tray or ladder

Long Span Tray (use one KLWC 16... on every second rung)

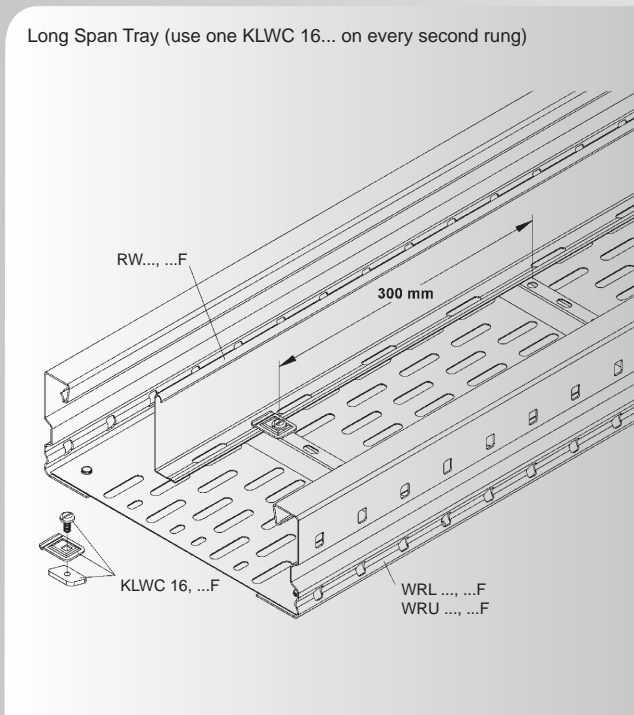

Long Span Ladder (use one KLWC 16 E3 on every second rung)
Please preassemble the KLWC 16 E3 before inserting the sliding nut into the rung.

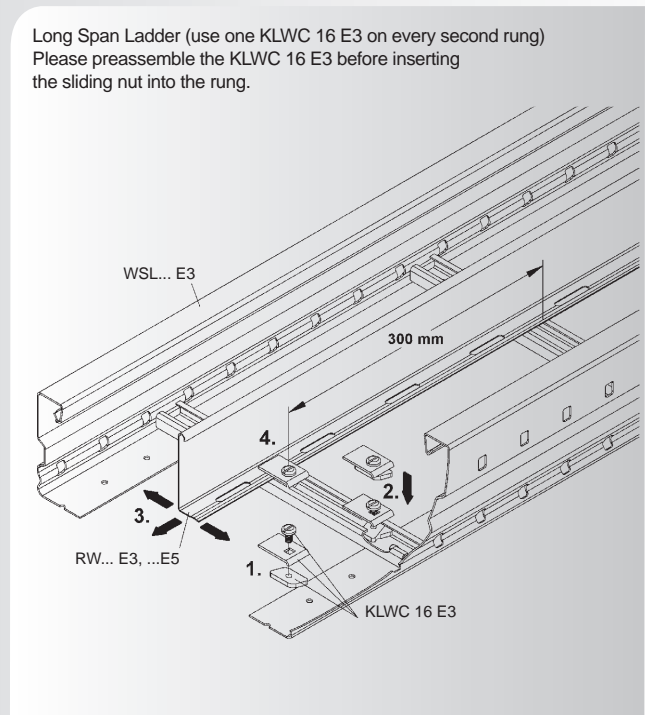

GENERAL INFORMATION

Installation Instructions

How to Build a Tee Offset

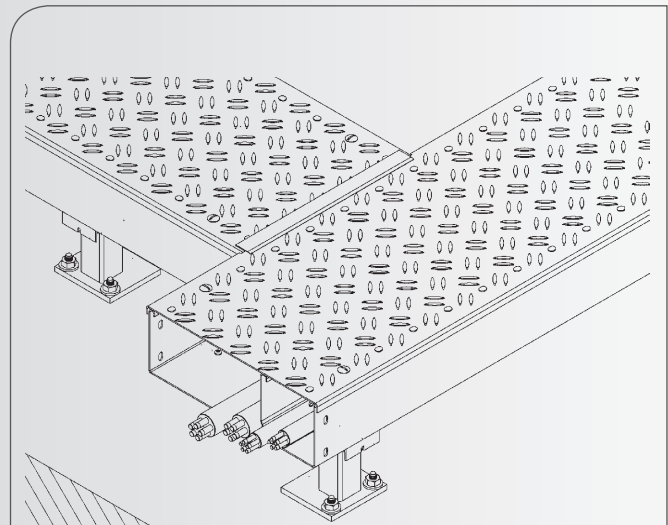
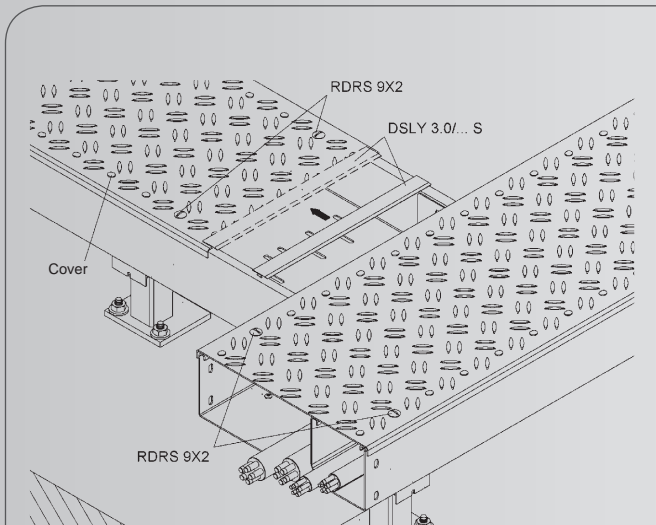
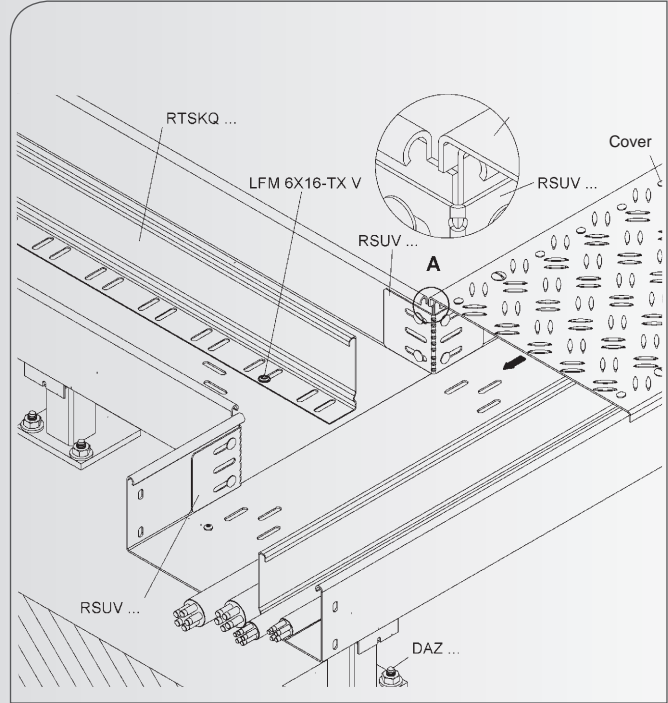
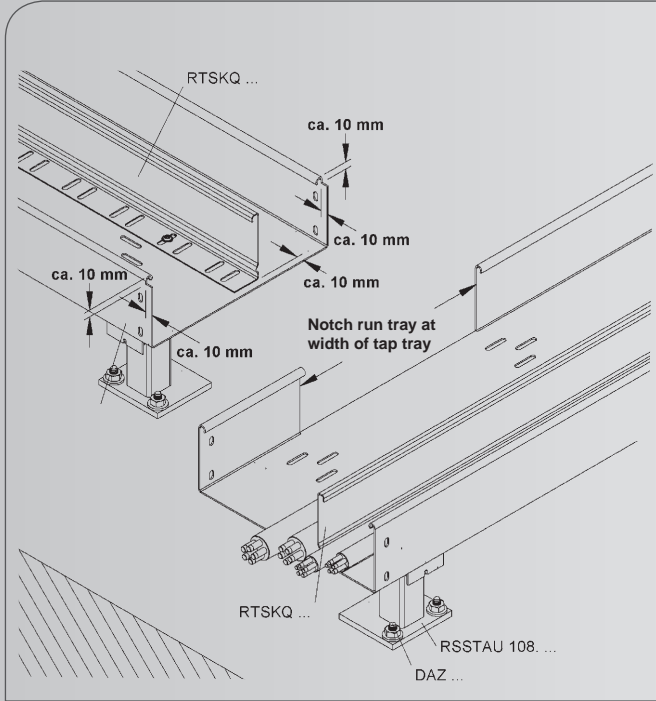

Installation Instructions

How to Install Flexible Dividers RTSQF...

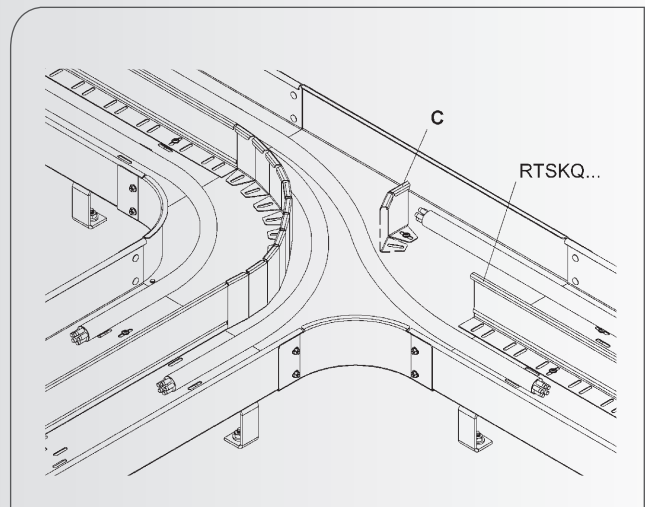
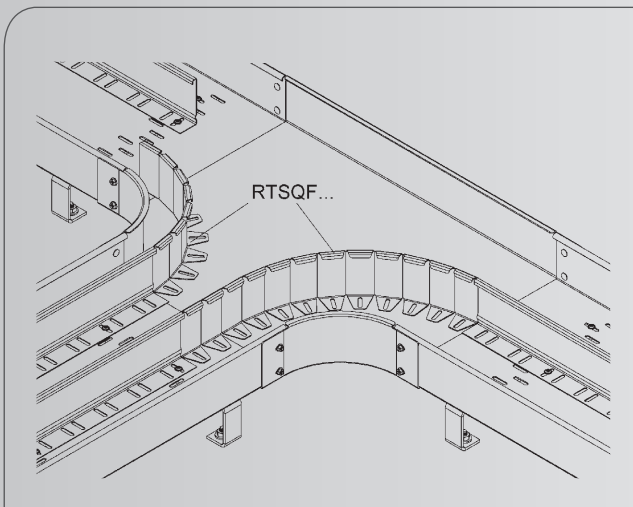
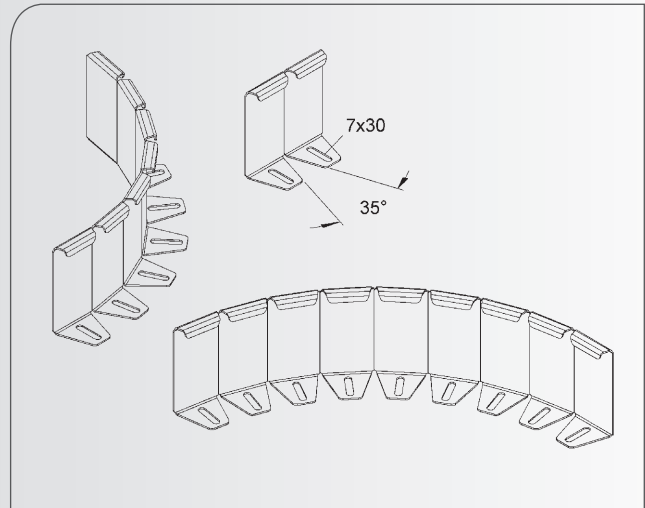
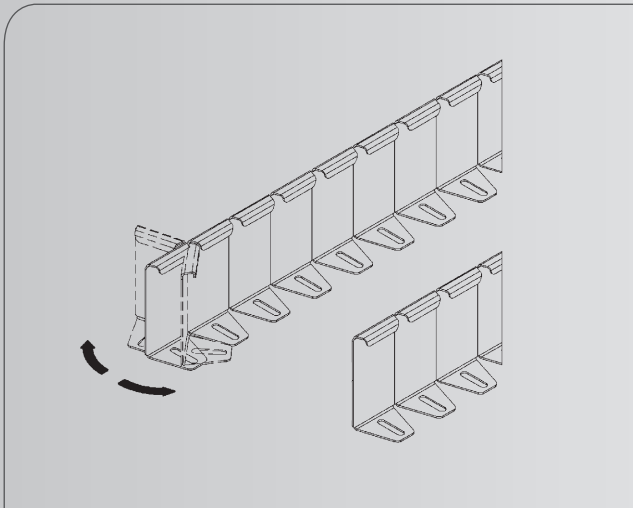
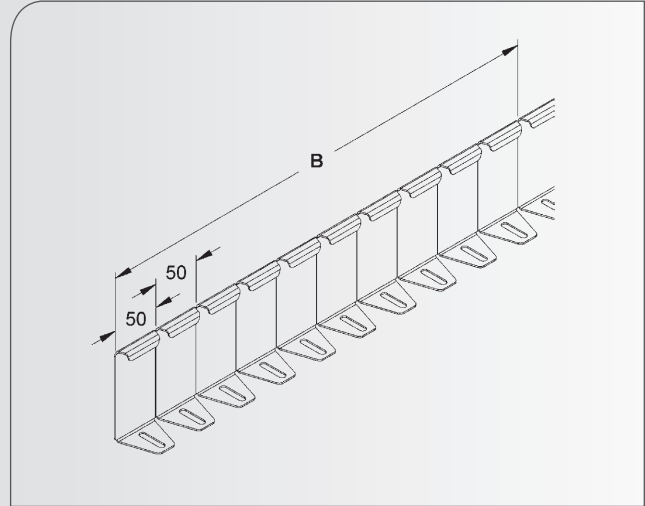
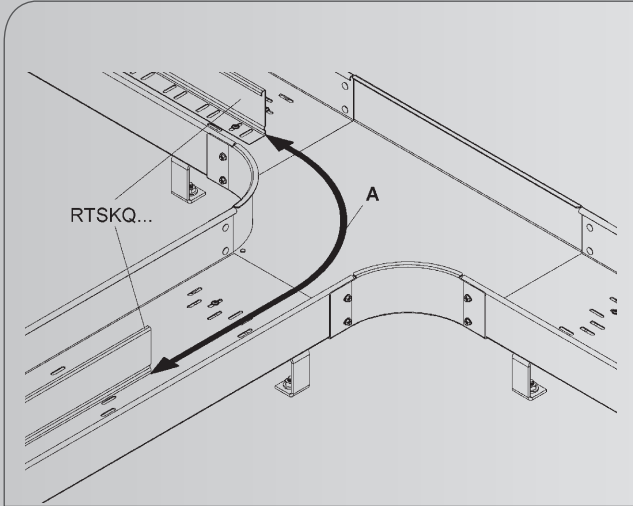

GENERAL INFORMATION

Installation Instructions

How to install/deinstall the cover clamp RDHFS 9 V

Install

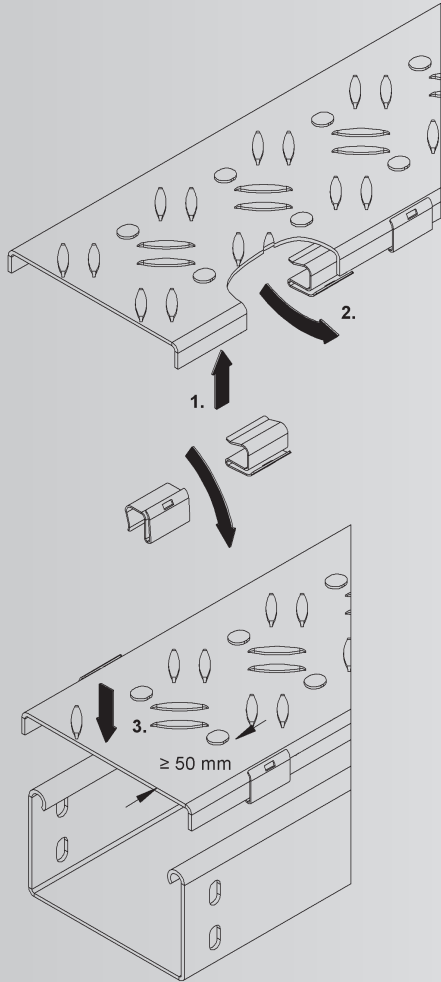

Deinstall

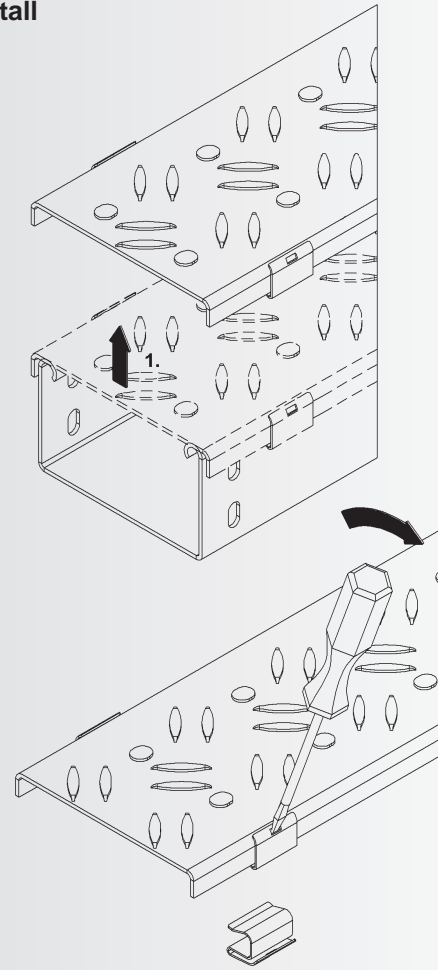

Recommended Number of Cover Clamps

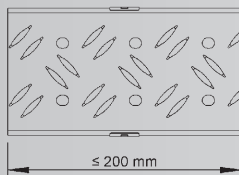

min. two RDHFS 9 V are required

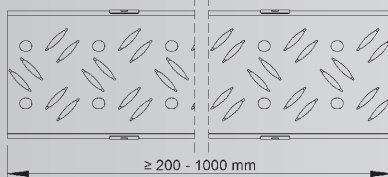

min. four RDHFS 9 V are required

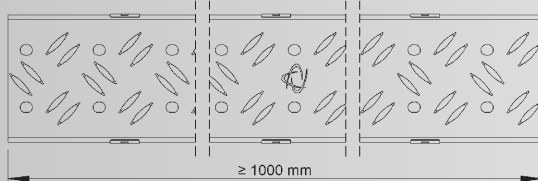

min. six RDHFS 9 V are required



Installation Instructions

How to Install Turnbolt Locks in RDRS 9X2 Covers

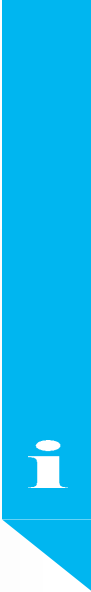
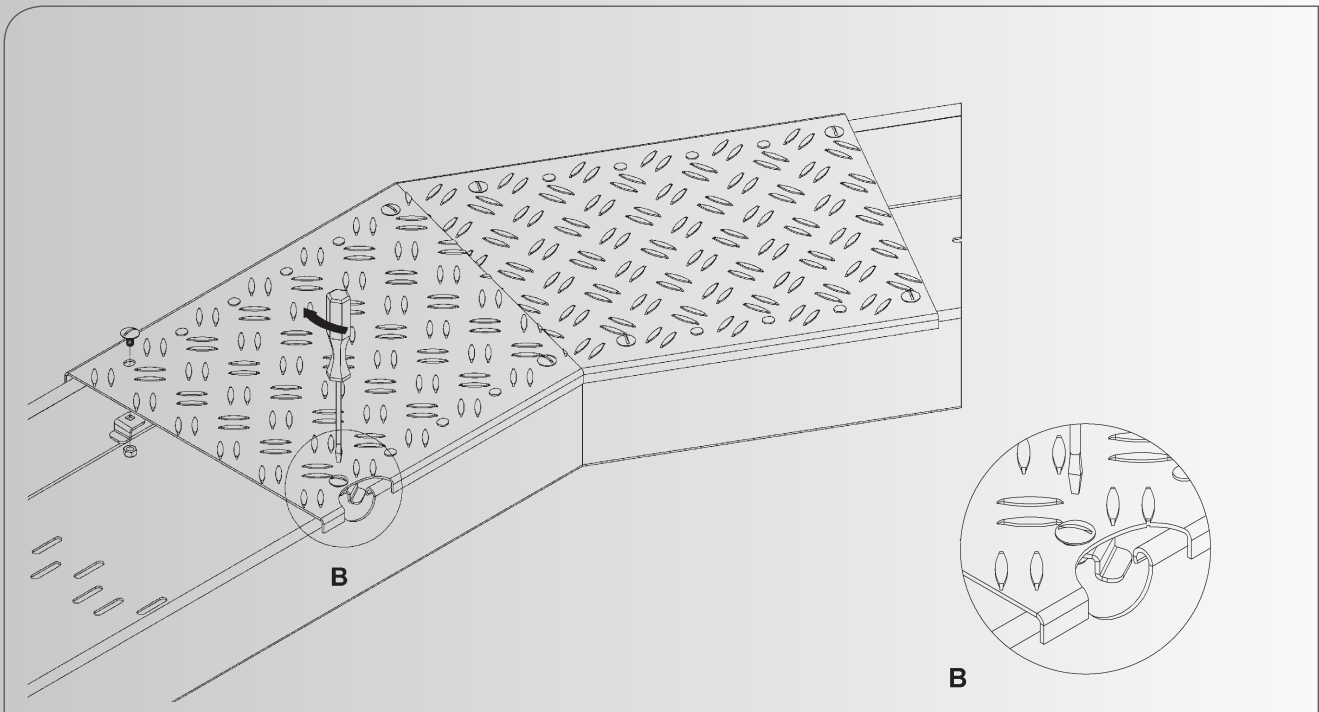
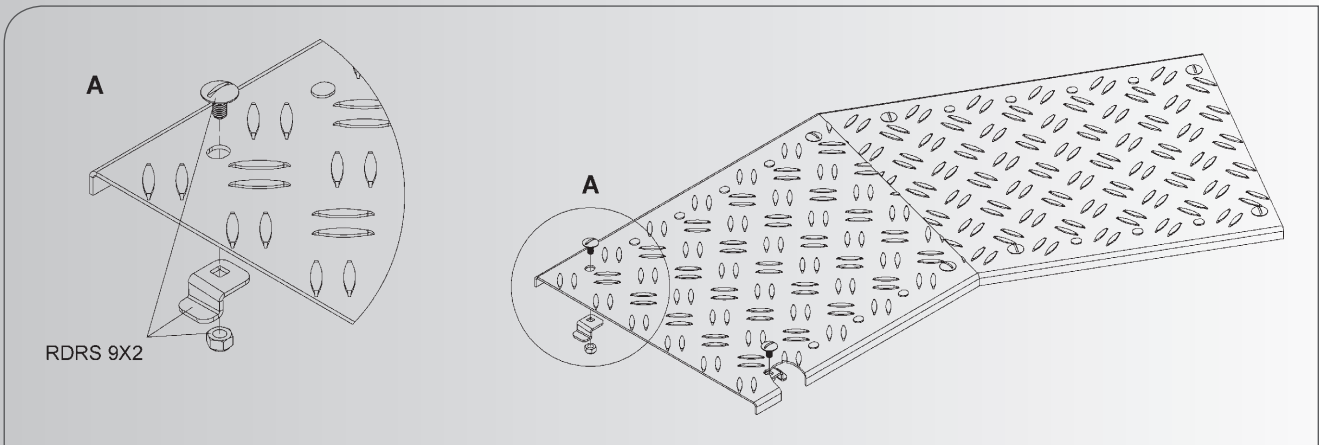
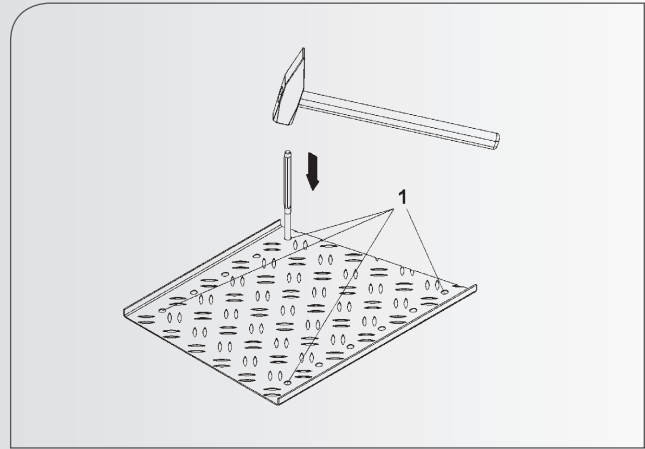
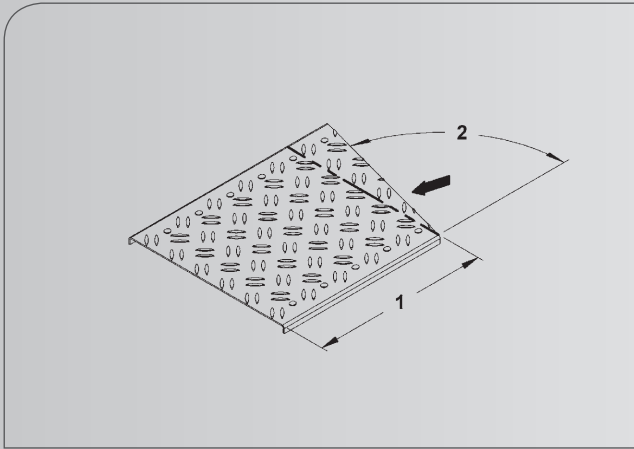

GENERAL INFORMATION

Installation Instructions

How to Install Skirting Panels to RSSTAA 108... and RSSTAU 108... Floorstands

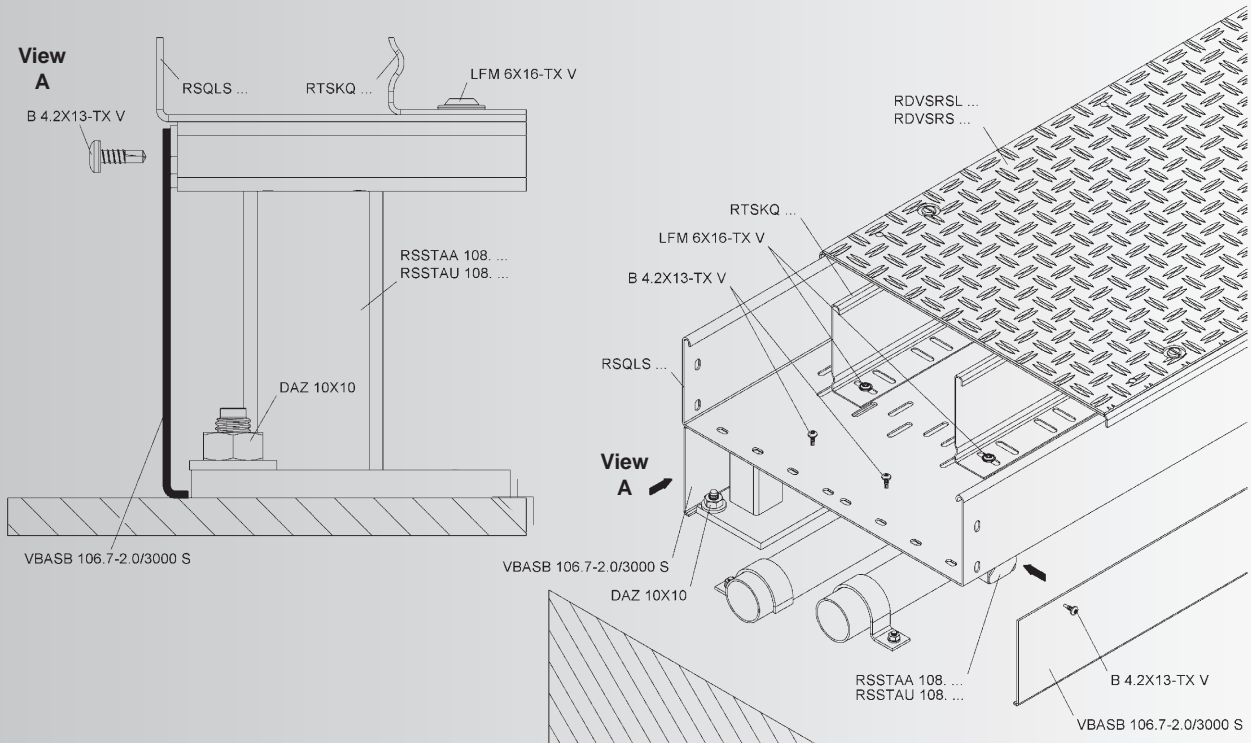

How to Install Skirting Panels to RDB 85... Floorstands

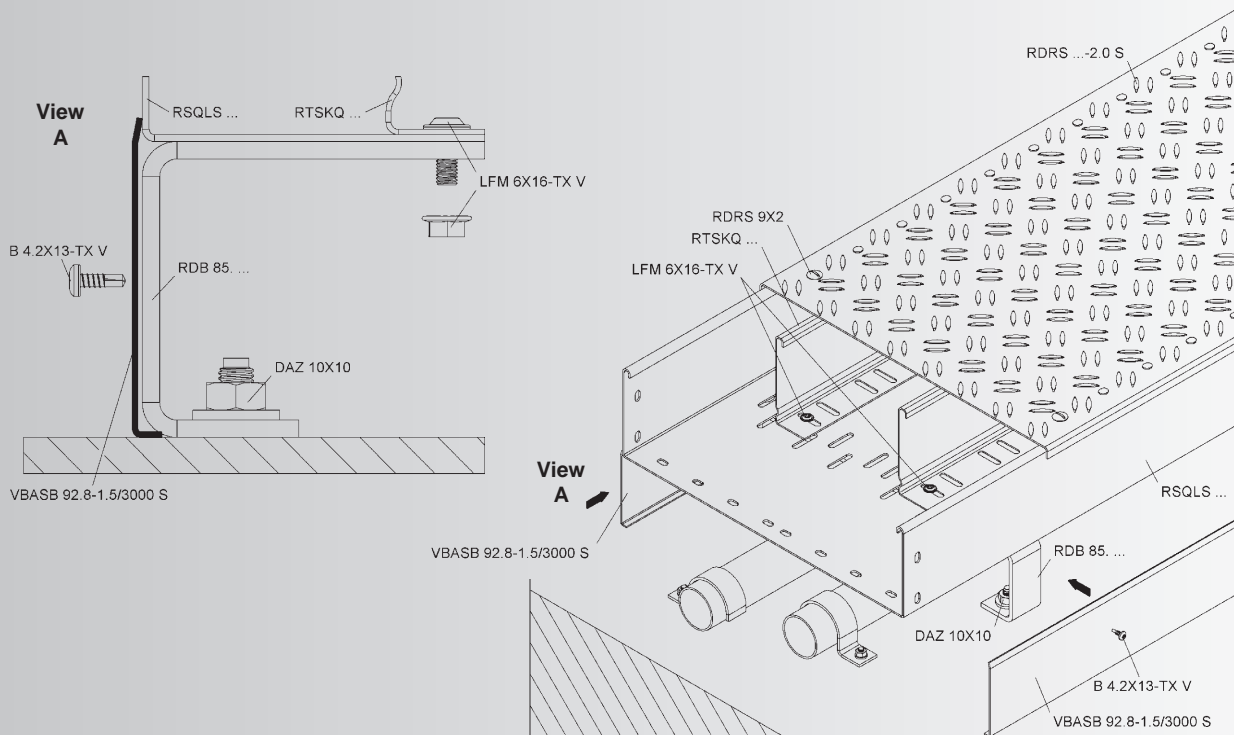

Installation Instructions

Long span ladder with horizontal fittings

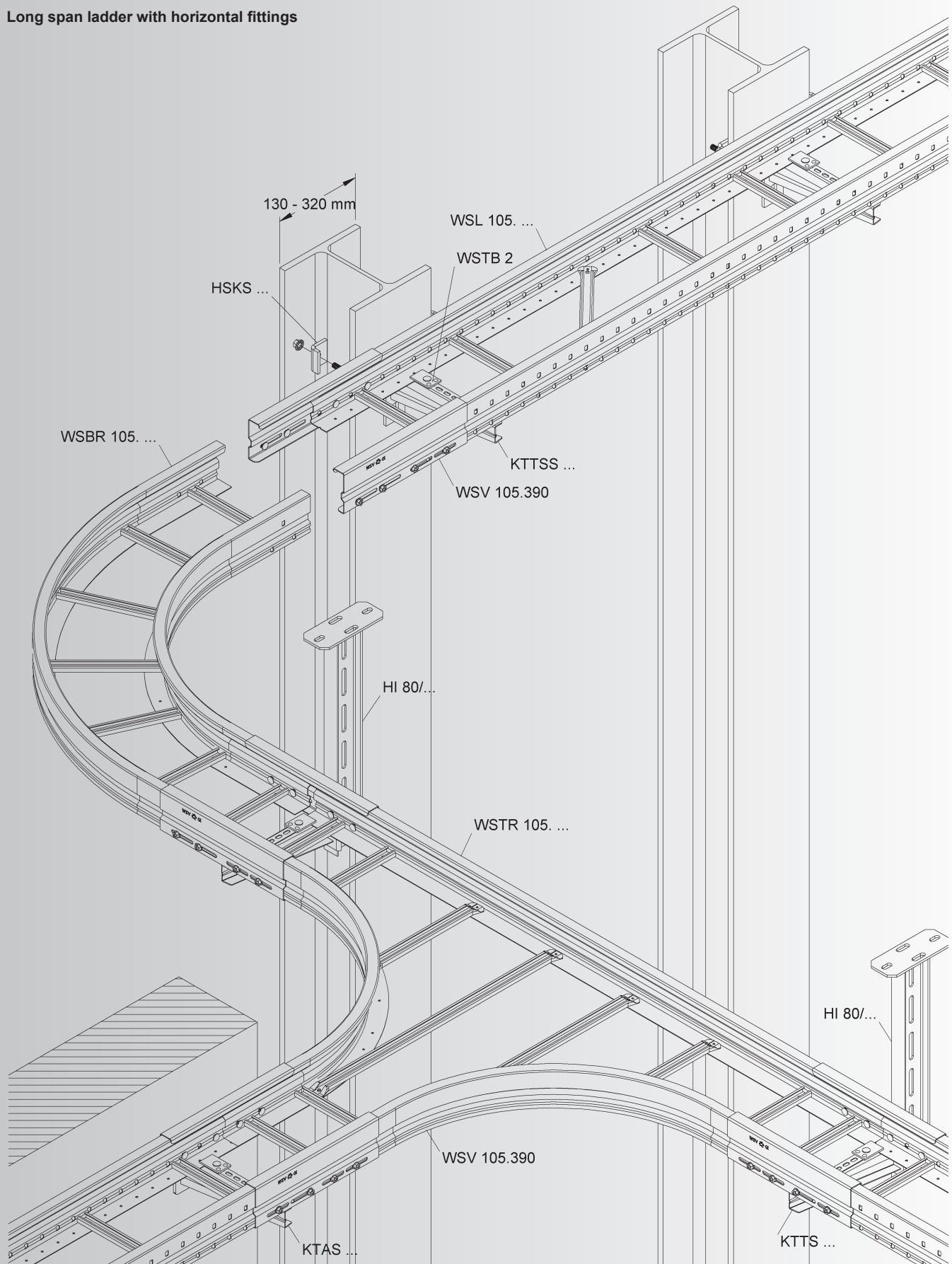

GENERAL INFORMATION

Installation Instructions

Long span ladder with vertical fittings

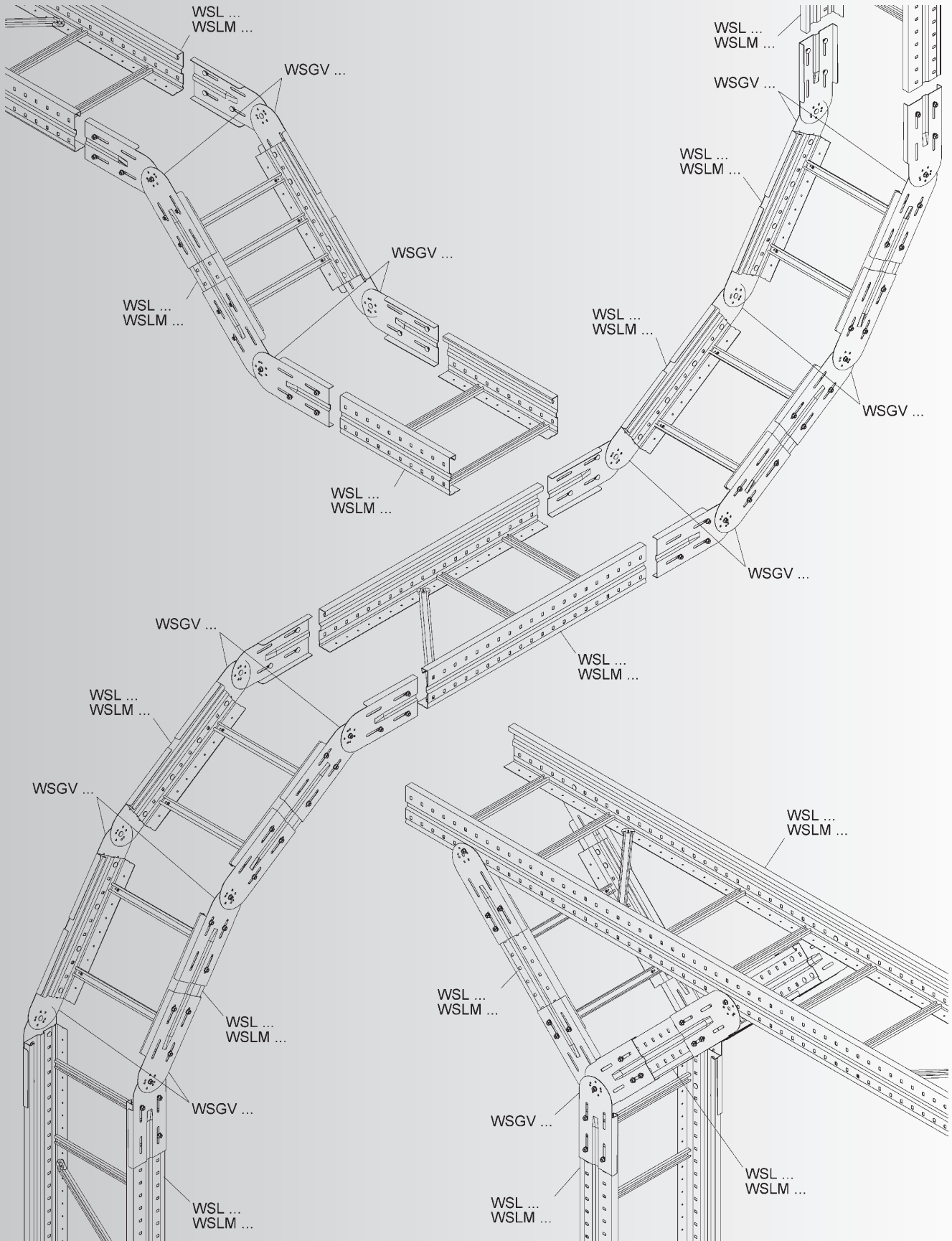

Installation Instructions

WRTAR...

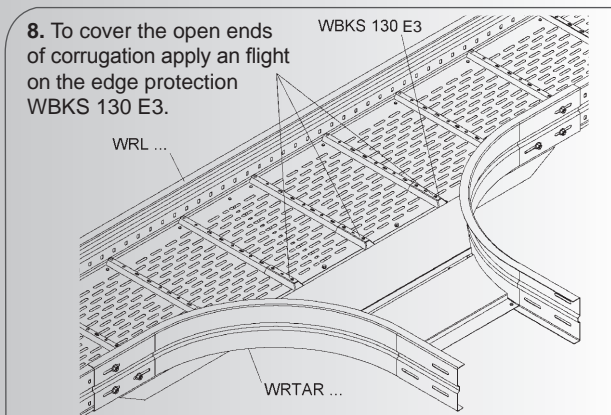
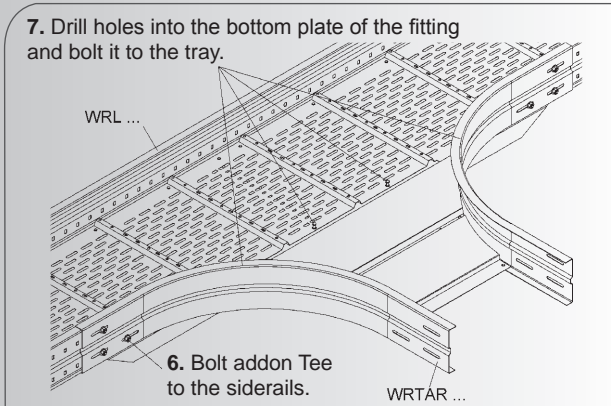
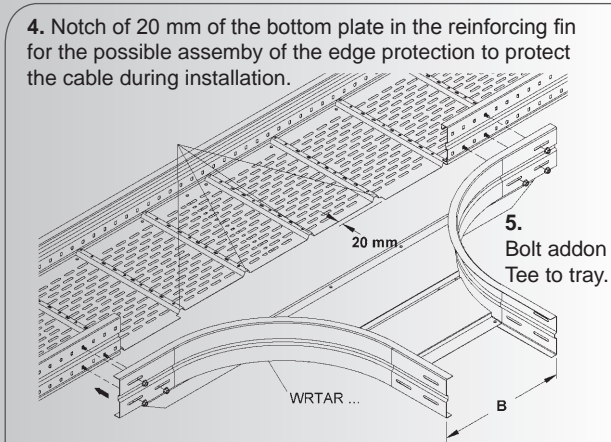
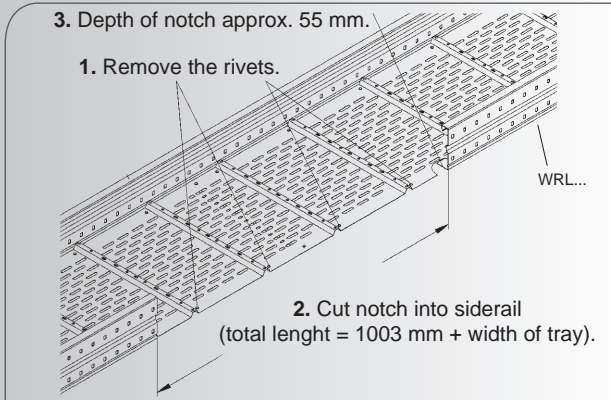

WSTAR...

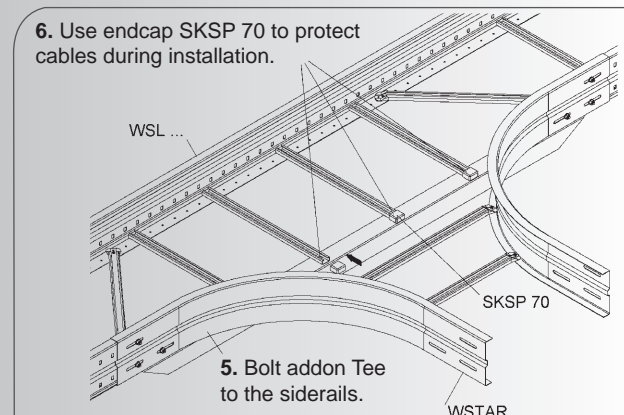
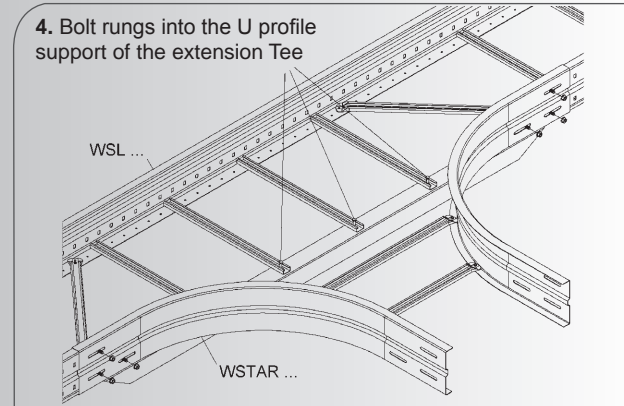
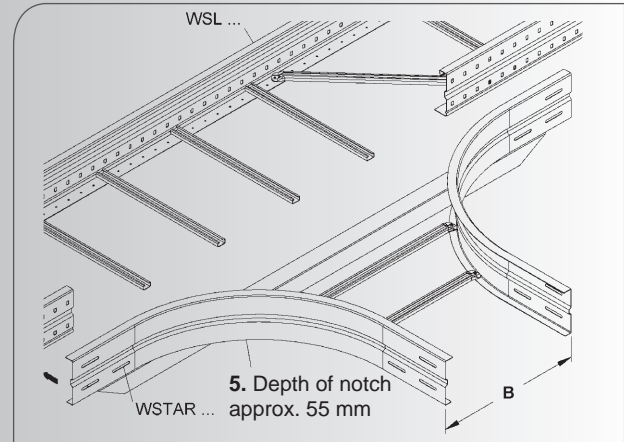
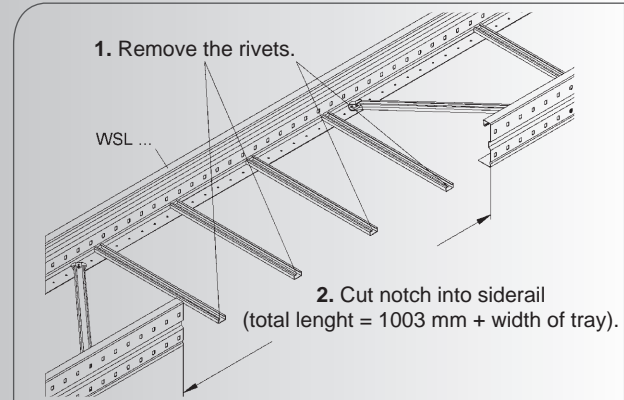

GENERAL INFORMATION

Installation Instructions

How to Build Long Span Reducers

Single Sided Reducer

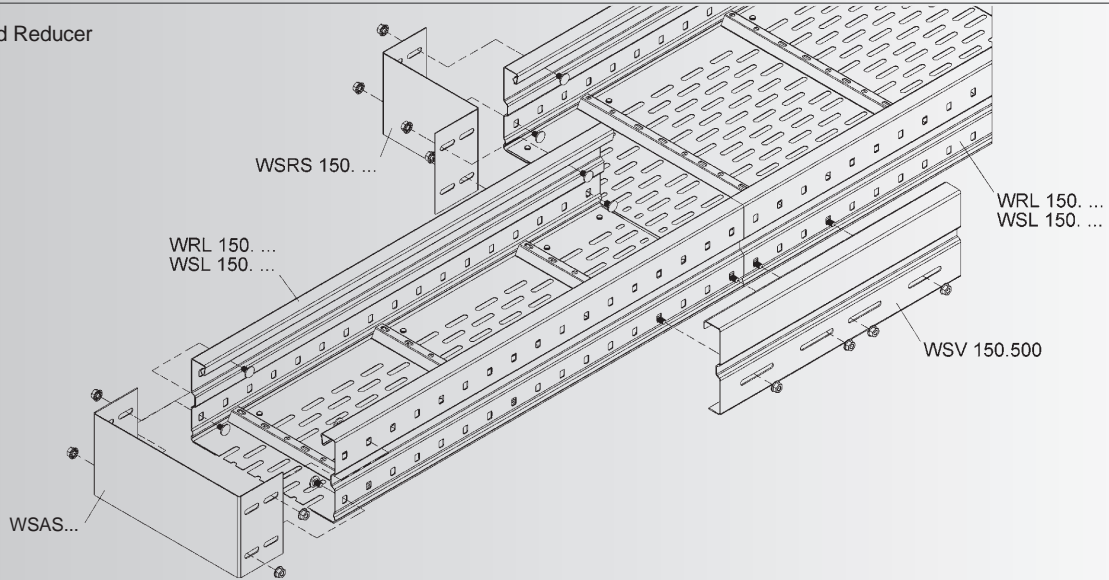

Asymmetrical Reducer

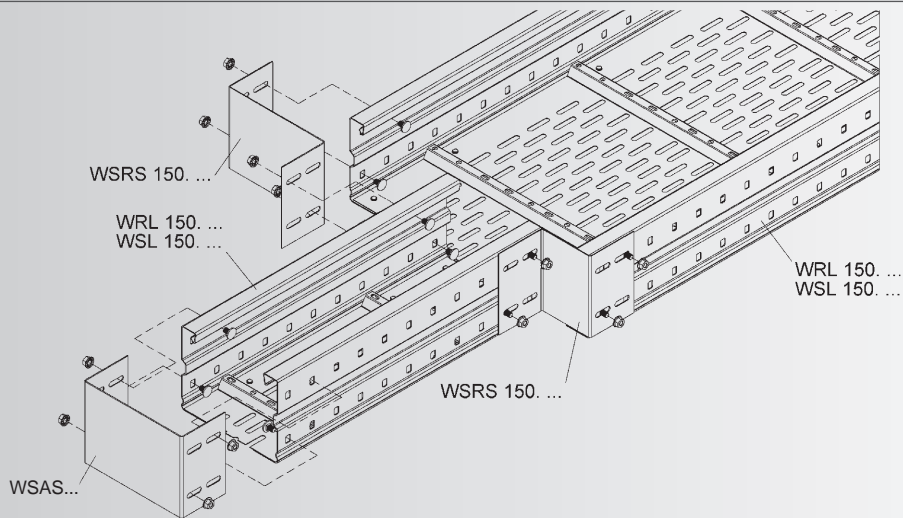

Symetrical Reducer

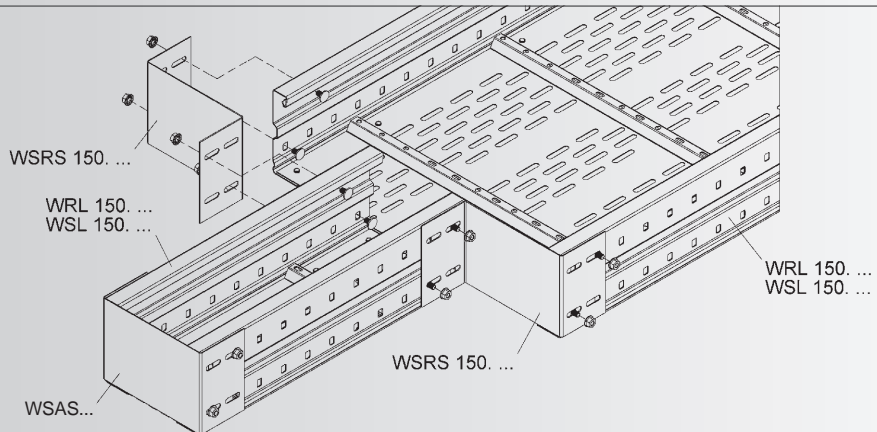

Installation Instructions

Installation of Divider using LZTP... mounting plate

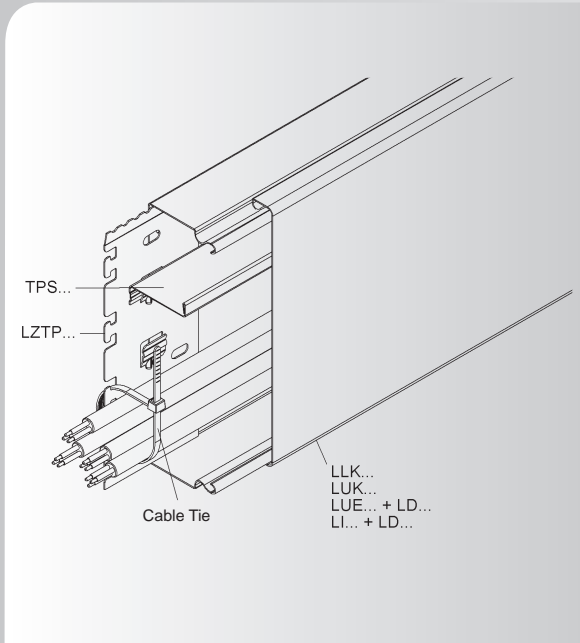

LZTP 100

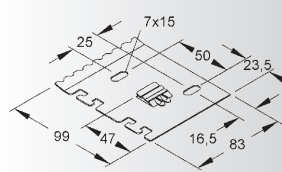

LZTP 150

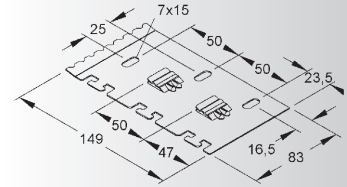

LZTP 200

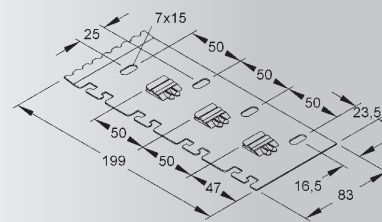

How to install channel cable tray LLK... and LUK... with Splice Plate LST...

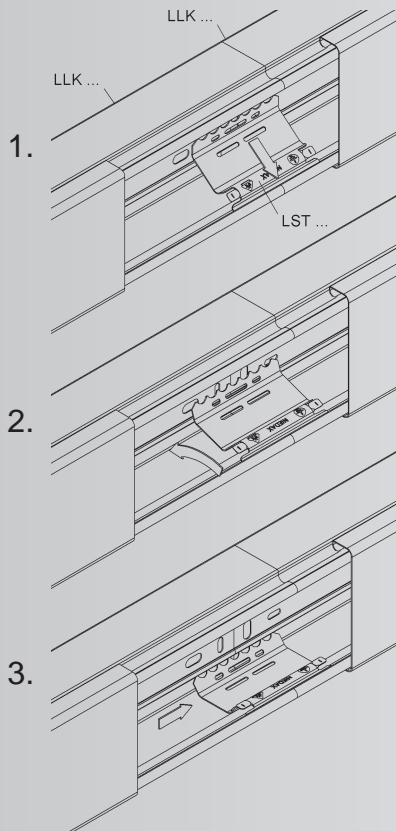

How to install the LSTA... splice plate

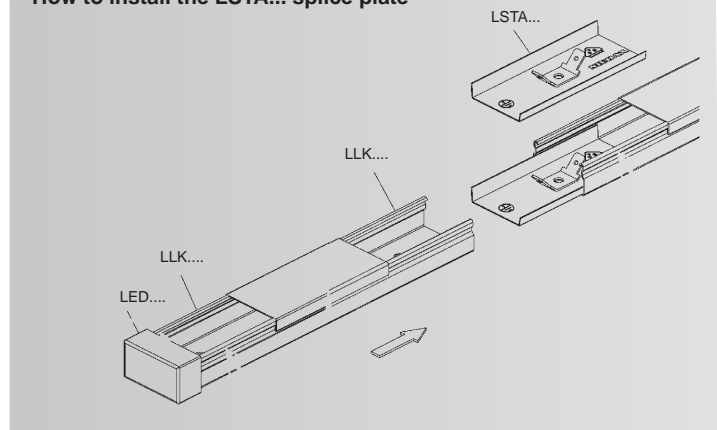

How to install the cable support clamp

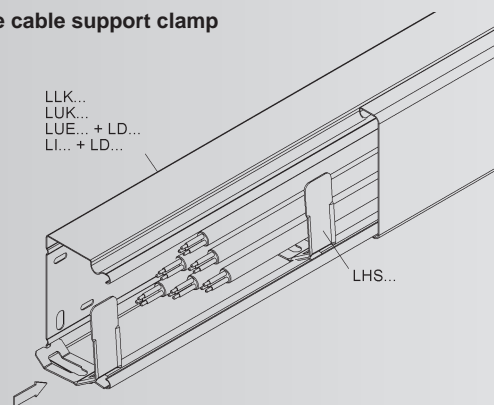

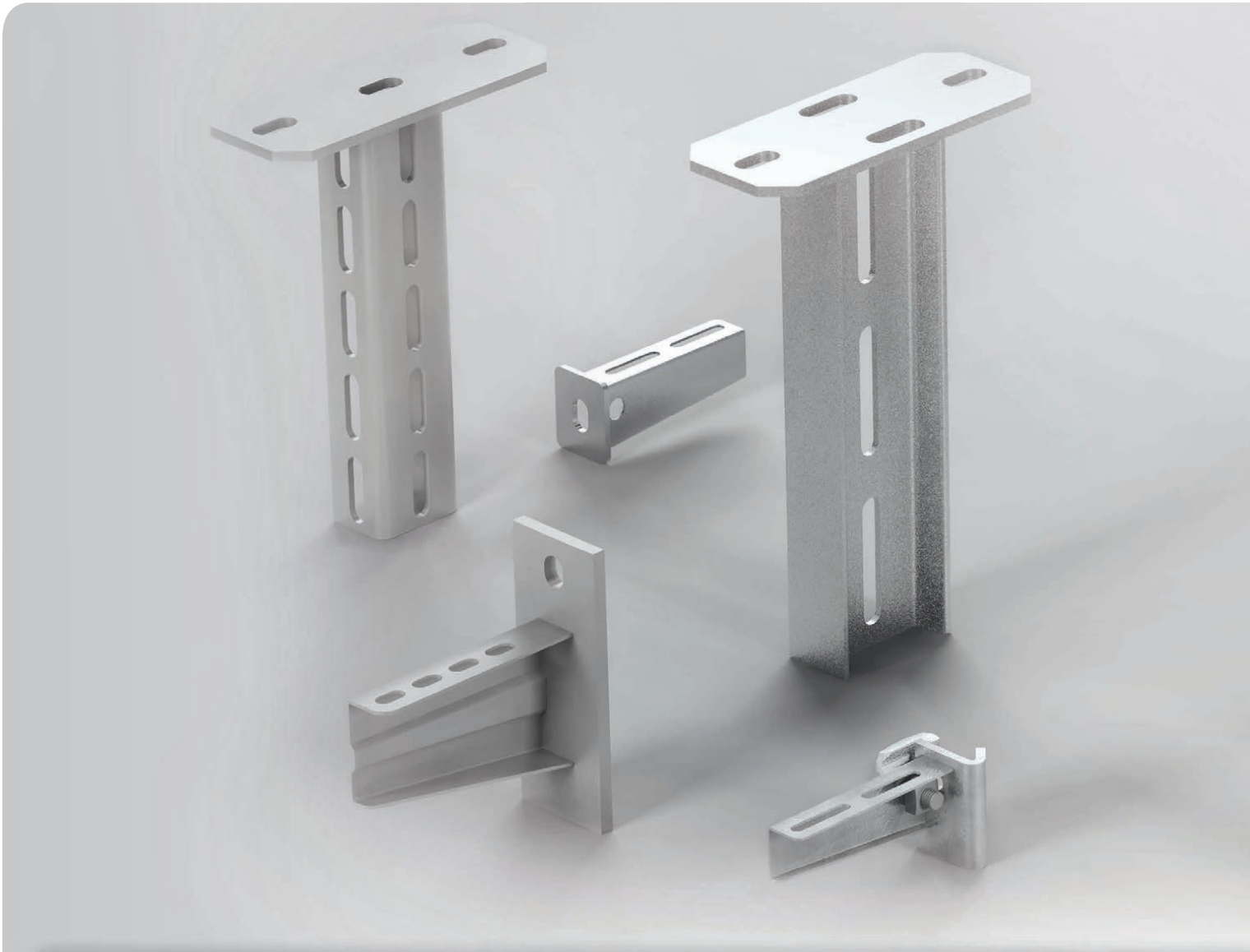

SUPPORT SYSTEM

- Overhead Hangers
- Brackets
- C-Profiles
- Head Plates





Niedax offers a wide variety of support systems for all kinds of applications. Light, medium and heavy duty versions of hangers and brackets for ceiling, floor and wall mount; clamping brackets and headplates for installing to steel structures; C- I- and U-profiles for metal framing; a wide range of accessories like serrated flange nuts, sliding nuts, threaded rod, anchor bolts, ...

Overview Brackets

SYSTEM	Overhead Hanger and Wall Bracket	KTCL...	Page 76
	Overhead Hanger and Wall Bracket	KTC...	Page 76
	Combination Bracket/Hanger	TKS...	Page 76
	Spacer	TKSD...	Page 77
	Wall/Ceiling Bracket	TKSU...	Page 78
	Protective End Cap	TKSK 30	Page 78
	Center Hanger/Trapeze Support	TW...	Page 79
	Bracket	KTAM...	Page 79
	Bracket	KTA...	Page 80
	Protective End Cap	KA 100-600	Page 80
★	Adjustable Wall Bracket	KTVW...	Page 80
	Clamping Adapter	KKAT 300	Page 81
	Clamping Adapter	KWAT 300	Page 82
	Beam Clamp	HSK...	Page 82
	Gripping Channel Nut	GMZF M10-18 F	Page 83
	Hexagonal Bolt	SK...	Page 83
	Hook Head Bolt	HK...	Page 83
	Bracket	KTAS...	Page 84
	Wall Bracket	KTASS...	Page 84
	Clamping Adapter	KKATS 400 F	Page 85
	Clamping Adapter	KWATS 300	Page 86
	Clamping Bracket	KTTSS...	Page 87
	Beam Clamp	HSKS...	Page 87
★	Hexagonal Bolt	SKM...	Page 87
	Box/Wall Connector	WA...	Page 88



admissible load F at $L/2 = kN$

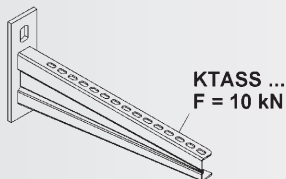
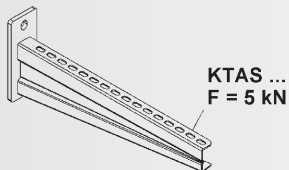
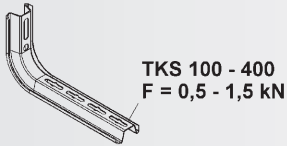
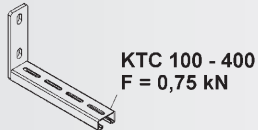
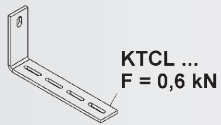
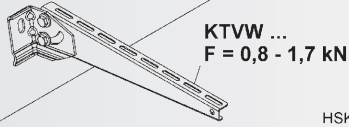

HSK ...
HK 610/...

HSK ...
GMZ M10
SK 10x...
(≥ 8.8)

HSKS ...
UGM 12
SKM 12x...
(10.9)

HSKS ...
UGM 12
SKM 12x...
(10.9)

HSKS ...
UGM 12
SKM 12x...
(10.9)

KWAT 300
F = F bracket

KTCL ...
KTC ...
KTAM ...
KTA ...

KKAT 300
F = F bracket

KTCL ...
KTC ...
KTAM ...
KTA ...

KKATS 400
F = F bracket

KTA ...
KTAS ...

KWATS 300
F = F bracket

KTAS ...
KTASS ...

KTSS ...
F = 5,7 - 10 kN

TW...

TKS 100 - 600
hanger
F = F bracket

TKS ...

TKSD ...

TKS ...

TKSK 30

TKS ...

TKSD ...

SKM 10x70

TKSU ...
F = 0,5 - 0,95 kN

WA ...

2986/...
GMZF M10-18...
F = F bracket

18

KTCL...
KTC...
KTAM...
KTA...

SUPPORT SYSTEM

Overhead Hanger and Wall Bracket

light

	model no.	height H		length A		thickness t mm	admissible load F at L/2 kN	Weight per 100 pc. kg	Pack/Box Qty
		mm	Inch	mm	Inch				
F	KTCL 100	106	4,2	110	4,3	4	0,6	26,9	20
F	KTCL 200	104	4,1	210	8,3	6	0,6	54,0	20

for mounting on walls or to overhead hangers

The load rating shown is valid only for proper anchorage to the building structure.

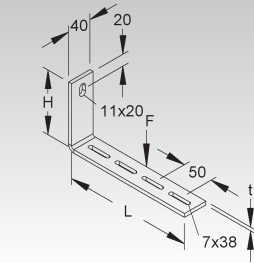

Overhead Hanger and Wall Bracket

standard

	model no.	height H		length A		admissible load F at L/2 kN	Weight per 100 pc. kg	Pack/Box Qty
		mm	Inch	mm	Inch			
F	KTC 100	114	4,5	104	4,1	0,75	44,9	20
F	KTC 200	114	4,5	204	8	0,75	61,5	20
F	KTC 300	114	4,5	304	12	0,75	78,1	20
F	KTC 400	114	4,5	404	15,9	0,75	94,7	20

for mounting cable tray in areas with little headroom

The load rating shown is valid only for proper anchorage to the building structure.

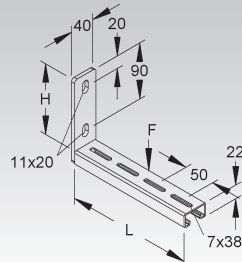

Combination Bracket/Hanger

	model no.	height H		length A		admissible load F at L/2 kN	Weight per 100 pc. kg	Pack/Box Qty
		mm	Inch	mm	Inch			
S	TKS 100	132	5,2	163	6,4	1,50	33,58	20
S	TKS 150	132	5,2	213	8,4	1,20	39,83	20
S	TKS 200	132	5,2	263	10,4	1,10	46,08	20
S	TKS 300	132	5,2	363	14,3	0,75	58,57	20
S	TKS 400	132	5,2	463	18,2	0,50	71,07	20
E3	TKS 100 E3	132	5,2	163	6,4	1,50	33,97	20
E3	TKS 200 E3	132	5,2	263	10,4	1,10	46,55	20
E3	TKS 300 E3	132	5,2	363	14,3	0,75	59,12	20
E3	TKS 400 E3	132	5,2	463	18,2	0,50	71,70	20

Always use TKSD 20 spacer to avoid deformation of TK type brackets when bolting to wall or ceiling.

1. for back to back mounting of hangers
2. for single sided mounting of hangers

The load rating shown is valid only for proper anchorage to the building structure.

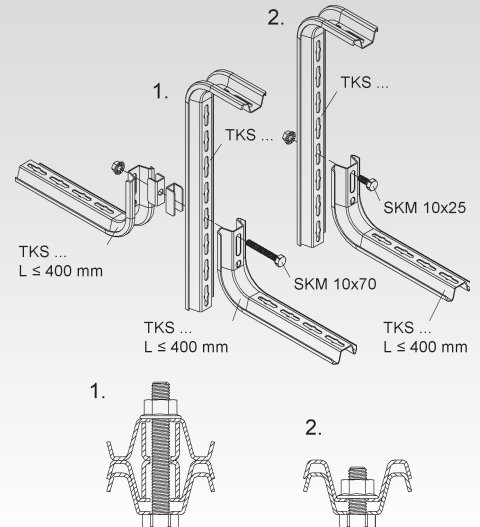
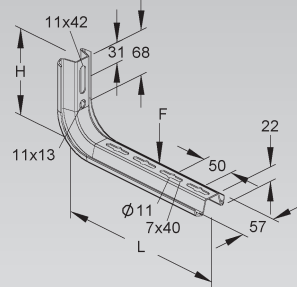

Spacer

model no.	Weight per 100 pc. kg	Pack/Box Qty
S TKSD 20	3,77	50

for secure wall and/or ceiling mount of TKS... type brackets/hangers

Suitable for: TKS... and TKSU... type hangers and brackets

1. wall and ceiling mount
2. for back to back mounting of hangers
3. for mounting TKSU brackets to wall or ceiling

Please order SKM... bolts separately.

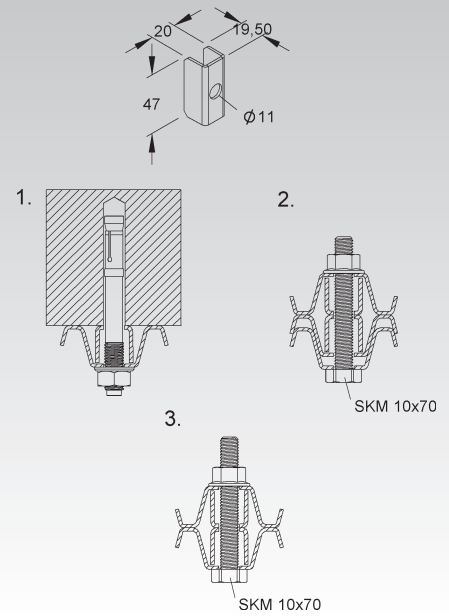

Spacer

model no.	Weight per 100 pc. kg	Pack/Box Qty
E3 TKSD 20 E3	2,9	50

for secure wall and/or ceiling mount of TKS... type brackets/hangers

1. wall and ceiling mount
2. for back to back mounting of hangers

Please order SKM... bolts separately.

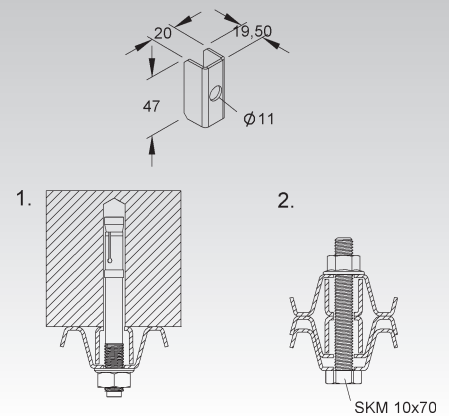

SUPPORT SYSTEM

Wall/Ceiling Bracket

	model no.	height H		length A		admissible load F at L/2 kN	Weight per 100 pc. kg	Pack/Box Qty
		mm	Inch	mm	Inch			
S	TKSU 100	172	6,8	161	6,3	0,95	50,83	20
S	TKSU 200	172	6,8	261	10,3	0,70	63,44	20
S	TKSU 300	172	6,8	361	14,2	0,50	76,05	20

for wall or ceiling mount

1. for back to back mounting of hangers
2. wall and ceiling mount

The load rating shown is valid only for proper anchorage to the building structure.

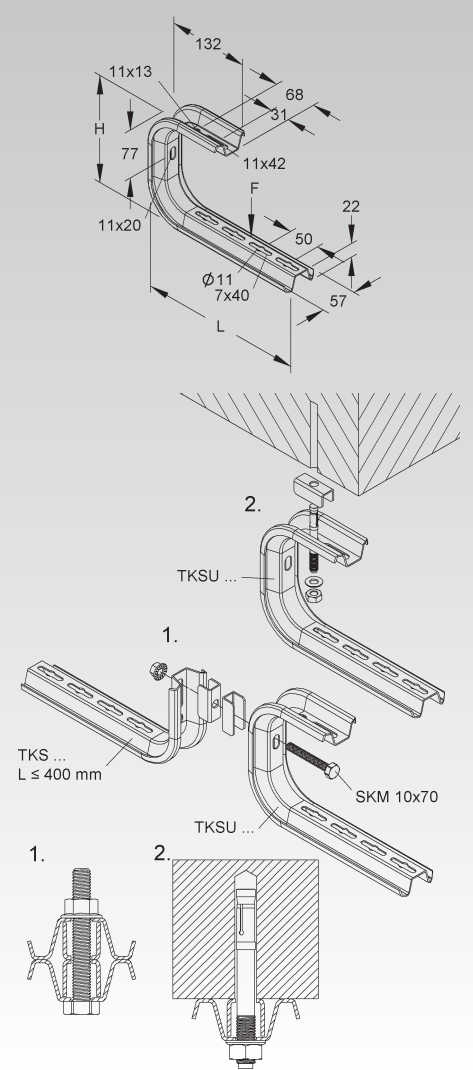

Protective End Cap

	model no.	color	Weight per 100 pc. kg	Pack/Box Qty

Suitable for: TKS... and TKSU... type hangers and brackets

Brackets have to be installed at least 50 mm above hangers end to allow an easy mounting of the protective end cap.

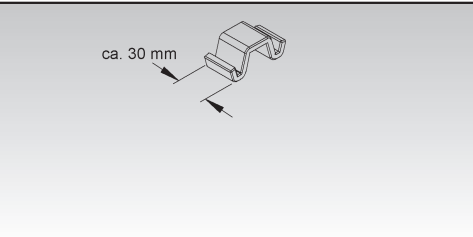

Center Hanger/Trapeze Support

model no.		width B	Weight per 100 pcs kg	Pack/ Box Qty
		mm Inch		
S	TW 100	98 3,9	10,65	10
S	TW 150	148 5,8	15,50	10
S	TW 200	190 7,5	18,99	10
S	TW 250	240 9,4	23,84	10
S	TW 300	290 11,4	28,11	10
S	TW 350	340 13,4	32,95	10
S	TW 400	470 18,5	45,55	10
S	TW 500	570 22,4	55,24	10
S	TW 600	670 26,4	64,93	10
F	TW 100 F	98 3,9	11,81	10
F	TW 200 F	190 7,5	20,98	10
F	TW 300 F	290 11,4	31,01	10
F	TW 400 F	470 18,5	50,20	10
F	TW 500 F	570 22,4	60,85	10
F	TW 600 F	670 26,4	71,51	10
E3	TW 100 E3	98 3,9	10,73	10
E3	TW 200 E3	190 7,5	19,12	10
E3	TW 300 E3	290 11,4	28,29	10
E3	TW 350 E3	340 13,4	33,17	10
E3	TW 400 E3	470 18,5	45,85	10
E3	TW 500 E3	570 22,4	55,60	10
E3	TW 600 E3	670 26,4	65,35	10

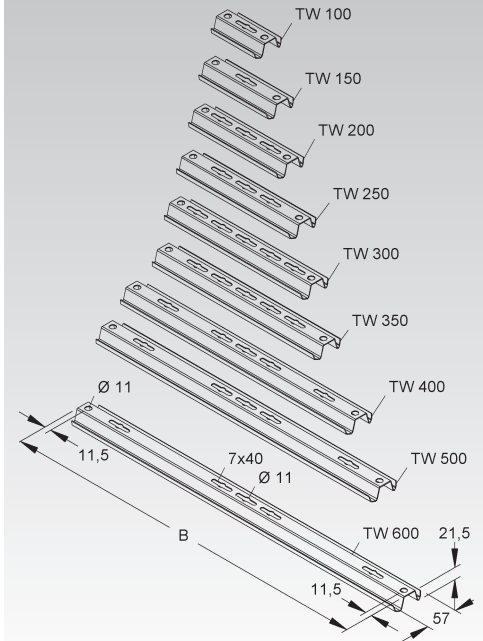

Suitable for: all ventilated cable trays and wire mesh basket

Bracket

medium duty

model no.		height H	length A	admissible load F at L/2 kN	Weight per 100 pcs kg	Pack/ Box Qty
		mm Inch	mm Inch			
S	KTAM 100	60 2,4	110 4,3	1,2	16,41	20
S	KTAM 200	80 3,1	210 8,3	1,2	30,27	20
S	KTAM 300	82 3,2	320 12,6	1,5	44,20	20
S	KTAM 400	82 3,2	420 16,5	1,5	50,28	20
F	KTAM 100 F	60 2,4	110 4,3	1,2	17,76	20
F	KTAM 200 F	80 3,1	210 8,3	1,2	33,01	20
F	KTAM 300 F	82 3,2	320 12,6	1,5	48,38	20
F	KTAM 400 F	82 3,2	420 16,5	1,5	55,27	20
E3	KTAM 100 E3	60 2,4	110 4,3	1,2	16,37	20
E3	KTAM 200 E3	80 3,1	210 8,3	1,2	30,32	20
E3	KTAM 300 E3	85 3,3	310 12,2	1,2	50,78	20

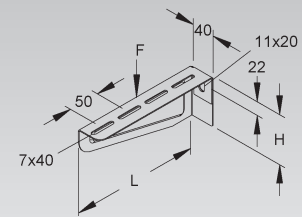

for mounting to overhead hangers or for direct wall mount

The load rating shown is valid only for proper anchorage to the building structure.

SUPPORT SYSTEM

Bracket

medium-duty

	model no.	height H		width B		length A		admissible load F at L/2 kN	Weight per 100 pcs kg	Pack/Box Qty
		mm	Inch	mm	Inch	mm	Inch			
F	KTA 100	45	1,8	40	1,6	110	4,3	2,5	15,66	20
F	KTA 150	45	1,8	40	1,6	160	6,3	2,5	19,05	20
F	KTA 200	55	2,2	40	1,6	210	8,3	2,5	27,55	20
F	KTA 250	55	2,2	40	1,6	260	10,2	2,5	32,21	20
F	KTA 300	65	2,6	50	2	310	12,2	2,5	59,17	20
F	KTA 350	65	2,6	50	2	360	14,2	2,5	66,35	20
F	KTA 400	75	3	50	2	410	16,1	2,5	79,17	20
F	KTA 450	75	3	50	2	460	18,1	2,5	88,02	10
F	KTA 500	90	3,5	50	2	510	20,1	2,5	111,06	10
F	KTA 550	90	3,5	50	2	560	22	2,5	134,20	10
F	KTA 600	90	3,5	50	2	610	24	2,5	127,48	10
E3	KTA 100 E3	45	1,8	40	1,6	110	4,3	2,5	14,63	20
E3	KTA 200 E3	55	2,2	40	1,6	210	8,3	2,5	25,46	20
E3	KTA 300 E3	65	2,6	50	2	310	12,2	2,5	55,52	20
E3	KTA 400 E3	90	3,5	50	2	410	16,1	2,5	73,51	20
E3	KTA 500 E3	110	4,3	50	2	510	20,1	2,5	112,96	10
E3	KTA 600 E3	110	4,3	50	2	610	24	2,5	130,67	10

for mounting to overhead hangers or for direct wall mount

The load rating shown is valid only for proper anchorage to the building structure. Please consult structural engineering for details and local regulations.

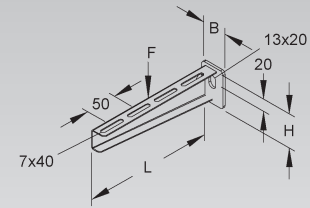

Protective End Cap

	model no.	color	Weight per 100 pcs kg	Pack/Box Qty
K10	KA 100-600	yellow	1,4	10

protective end cap for cable tray brackets

Suitable for: KTA..., KTT... and KTU... brackets

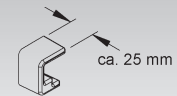

Adjustable Wall Bracket

	model no.	support length L1 mm	Total length L1 mm	admissible load F at L/2 kN	Weight per 100 kg	Pack/Box Qty
★ F	KTWV 150 F	165	190	1,70	75,15	10
★ F	KTWV 200 F	215	240	1,65	82,04	10
★ F	KTWV 250 F	265	290	1,60	88,93	10
★ F	KTWV 300 F	315	340	1,55	95,84	10
★ F	KTWV 350 F	365	390	1,50	102,75	10
★ F	KTWV 400 F	415	440	1,40	109,66	10
★ F	KTWV 450 F	465	490	1,30	116,58	10
★ F	KTWV 500 F	515	540	1,20	139,85	10
★ F	KTWV 550 F	565	590	1,10	148,36	10
★ F	KTWV 600 F	615	640	1,00	156,89	10
★ F	KTWV 650 F	665	690	0,90	185,86	10
★ F	KTWV 700 F	715	740	0,80	195,93	1

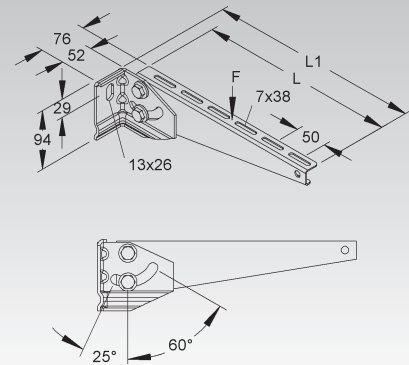

Clamping Adapter

model no.	slot width mm Inch	admissible load F at L/2 kN	Weight per 100 pc. kg	Pack/ Box Qty
F KKAT 300	22 0,9	1,5	140,73	10

for installing support brackets in a 90° angle to the I-beam, flange width ≤ 300 mm

Suitable for: KTAL..., KTAM..., KTA..., KTCL... and KTC... type brackets

First install the bracket to the adaptor.

The clamping should be done symmetrical and the bolts should be fixed as close as possible to the flange.

Hardware has to be ordered separately:

2 x HK 610/..., 2 x HSK...

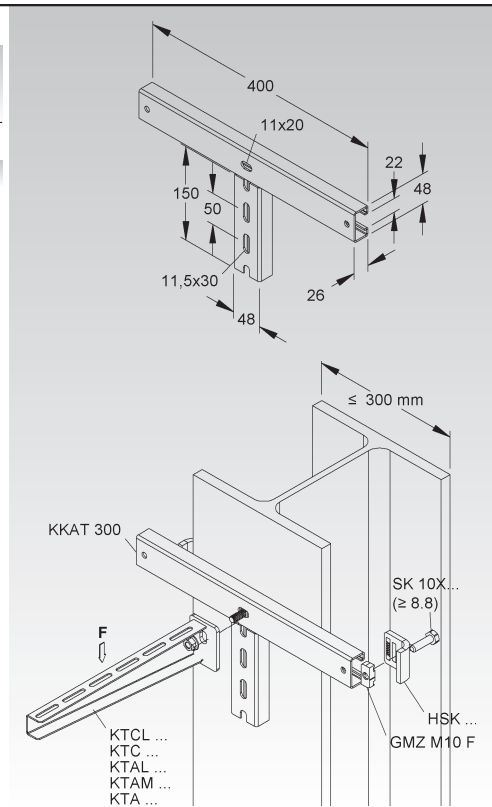

SUPPORT SYSTEM

Clamping Adapter

model no.	slot width mm Inch	Weight per 100 pc. kg	Pack/ Box Qty
F KWAT 300	22 0,9	257,38	1

for installing support brackets in a 45° angle to the I-beam, flange width ≤ 300 mm

Suitable for: KTAM..., KTA..., KTCL... and KTC...type brackets

First install the bracket to the adaptor. When using a 45° adaptor the required length of the bracket depends on the fitting used.

The clamping should be done symmetrical and the bolts should be fixed as close as possible to the flange.

hardware has to be ordered separately:
4x HK 610/..., 4x HSK...

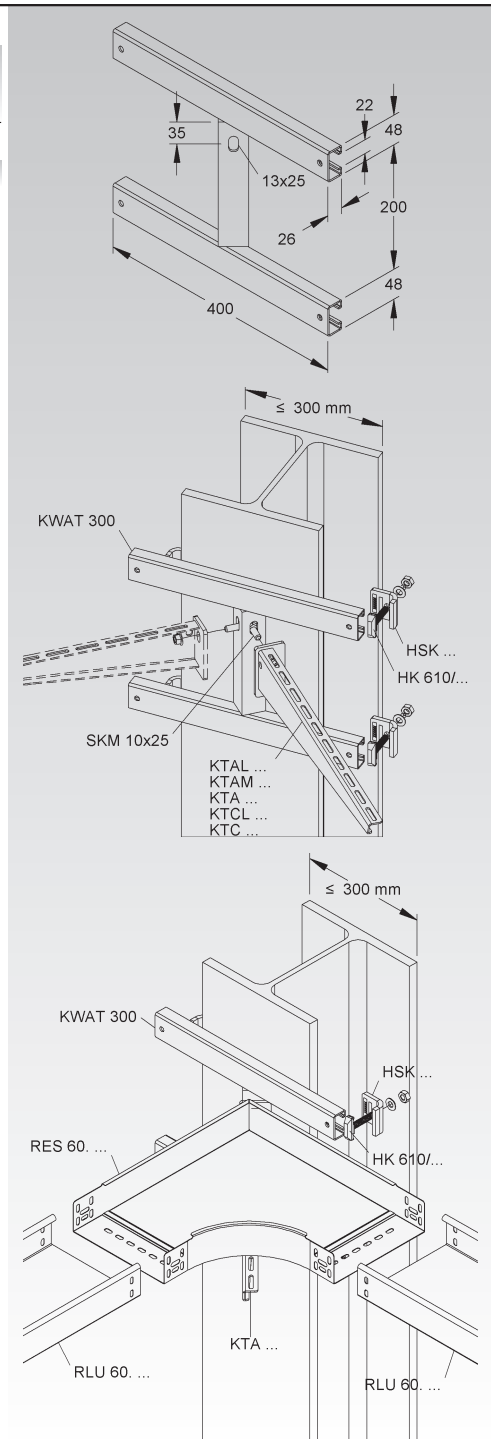

Beam Clamp

model no.	height H mm Inch	thick- ness t mm	flange thickness t mm	Weight per 100 pcs kg	Pack/ Box Qty
F HSK 10	10 0,4	7	5 - 9	15,44	50
F HSK 15	15 0,6	7	10 - 14	16,92	50
F HSK 20	20 0,8	7	15 - 19	18,43	50
F HSK 25	25 1	7	20 - 24	19,95	50
F HSK 30	30 1,2	7	25 - 29	21,46	50
F HSK 35	35 1,4	7	30 - 34	22,97	50
F HSK 40	40 1,6	7	35 - 39	24,48	50

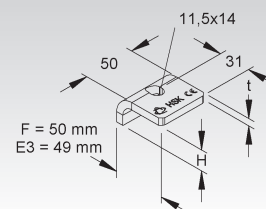

Gripping Channel Nut

model no.	thread M	strength category	Weight per 100 pcs kg	Pack/ Box Qty
F GMZF M10-18 F	10	8	3,36	100

Suitable for: 2986... and 2988... framing channel (18 mm slotwidth)

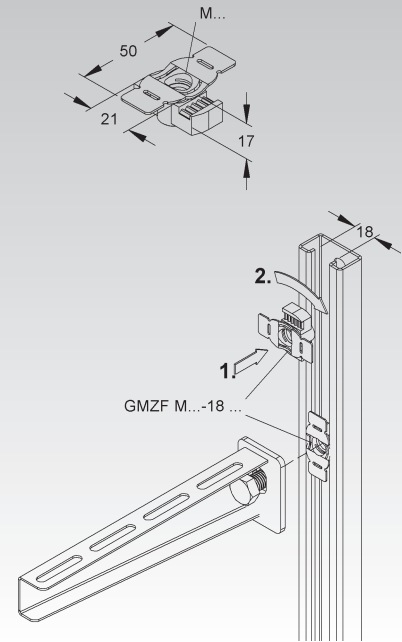

Hexagonal Bolt

model no.	length A		strength category	wrench size	Weight per 100 kg	Pack/ Box Qty
	mm	Inch				
F SK 10X25 F	25	1	8.8	17	2,55	100
F SK 10X35 F	35	1,4	8.8	17	2,87	100
F SK 10X50 F	50	2	8.8	17	3,82	100
F SK 10X60 F	60	2,4	8.8	17	4,44	100

SK10..., tightening torque 48 Nm, 17 mm metric wrench



Hook Head Bolt, size M10

nut and washer included

model no.	length A		strength category	Weight per 100 pcs kg	Pack/ Box Qty
	mm	Inch			
F HK 610/30 F	30	1,2	4.6	5,6	100
F HK 610/50 F	50	2	4.6	6,5	50

Suitable for: 2991... framing channel (22 mm slotwidth)

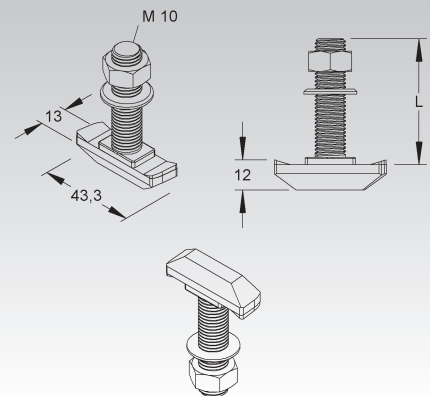

SUPPORT SYSTEM

Bracket

heavy-duty

model no.	height H		length A		admissible load F at L/2 kN	Weight per 100 pcs kg	Pack/Box Qty
	mm	Inch	mm	Inch			
F KTAS 100	113	4,4	130	5,1	5	90,05	1
F KTAS 200	113	4,4	230	9,1	5	108,56	1
F KTAS 300	113	4,4	330	13	5	130,86	1
F KTAS 400	113	4,4	430	16,9	5	155,49	1
F KTAS 500	150	5,9	530	20,9	5	197,79	1
F KTAS 600	150	5,9	630	24,8	5	227,10	1
F KTAS 700	150	5,9	730	28,7	5	303,33	1
F KTAS 800	195	7,7	830	32,7	5	364,47	1
F KTAS 900	195	7,7	930	36,6	5	409,88	1
F KTAS 1000	195	7,7	1030	40,6	5	458,21	1
E3 KTAS 200 E3	113	4,4	230	9,1	5	99,32	1
E3 KTAS 300 E3	113	4,4	330	13	5	119,72	1
E3 KTAS 400 E3	113	4,4	430	16,9	5	142,25	1
E3 KTAS 500 E3	150	5,9	530	20,9	5	181,00	1
E3 KTAS 600 E3	150	5,9	630	24,8	5	207,76	1

for mounting to overhead hangers or for direct wall mount

The load rating shown is valid only for proper anchorage to the building structure. Please consult structural engineering for details and local regulations.

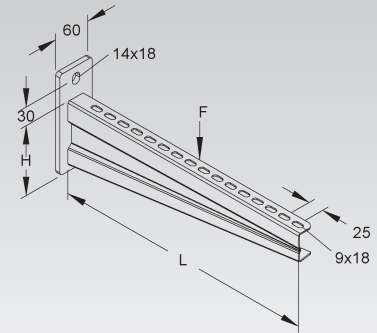
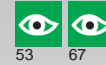

Wall Bracket

extra heavy-duty version

model no.	height H		height E	length A		admissible load F at L/2 kN	admissible load F2 at L/2 kN	Weight per 100 pcs kg	Pack/Box Qty	
	mm	Inch		mm	Inch					
F KTASS 200	83	3,3	115	4,5	230	9,1	10	10,0	112,31	1
F KTASS 300	108	4,3	140	5,5	330	13	10	10,0	150,58	1
F KTASS 400	133	5,2	165	6,5	430	16,9	10	10,0	191,76	1
F KTASS 500	133	5,2	165	6,5	530	20,9	10	9,5	225,51	1
F KTASS 600	158	6,2	190	7,5	630	24,8	10	9,5	309,34	1
F KTASS 700	158	6,2	190	7,5	730	28,7	10	8,5	356,87	1
F KTASS 800	183	7,2	215	8,5	830	32,7	10	8,5	418,26	1
F KTASS 900	183	7,2	215	8,5	930	36,6	10	7,5	472,79	1
F KTASS 1000	208	8,2	240	9,4	1030	40,6	10	7,5	541,19	1

for wall mount

The load rating shown is valid only for proper anchorage to the building structure. Please consult structural engineering for details and local regulations.

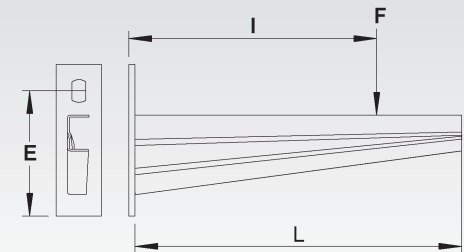
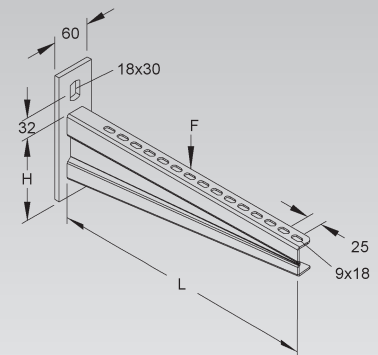

$$F = \sqrt{\frac{R^2}{1 + (l/E)^2}}$$



Clamping Adapter

model no.	Weight per 100 kg	Pack/Box Qty
F KKATS 400 F	386,75	1

for installing KTA/KTAS brackets to I-beams or concrete walls

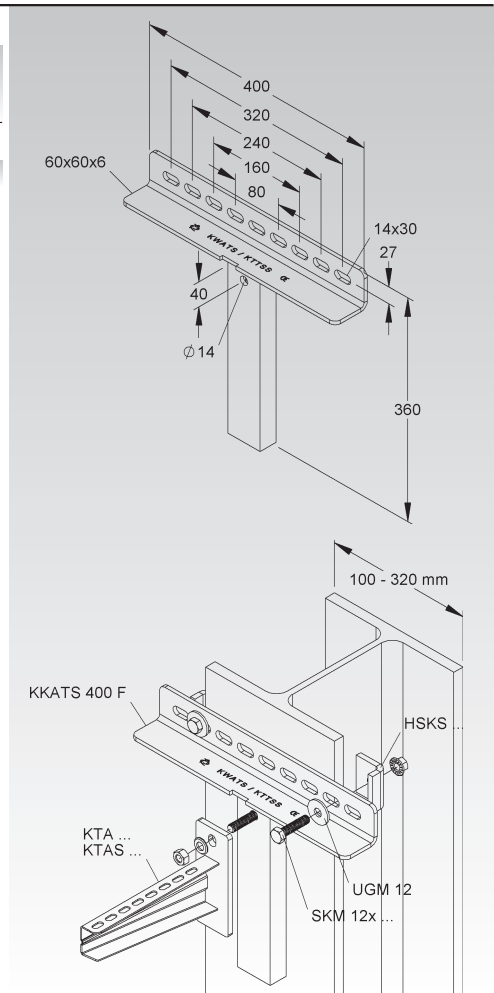

SUPPORT SYSTEM

Clamping Adapter

model no.	Weight per 100 pc. kg	Pack/Box Qty
F KWATS 300	676,77	1

for installing support brackets in a 45° angle to the I-beam

Suitable for: KTAS... and KTASS... type brackets

First install the bracket to the adaptor. When using a 45° adaptor the required length of the bracket depends on the fitting used.

The clamping should be done symmetrical and the bolts should be fixed as close as possible to the flange.

hardware has to be ordered separately: 4x HSKS..., 4x SKM 12x70

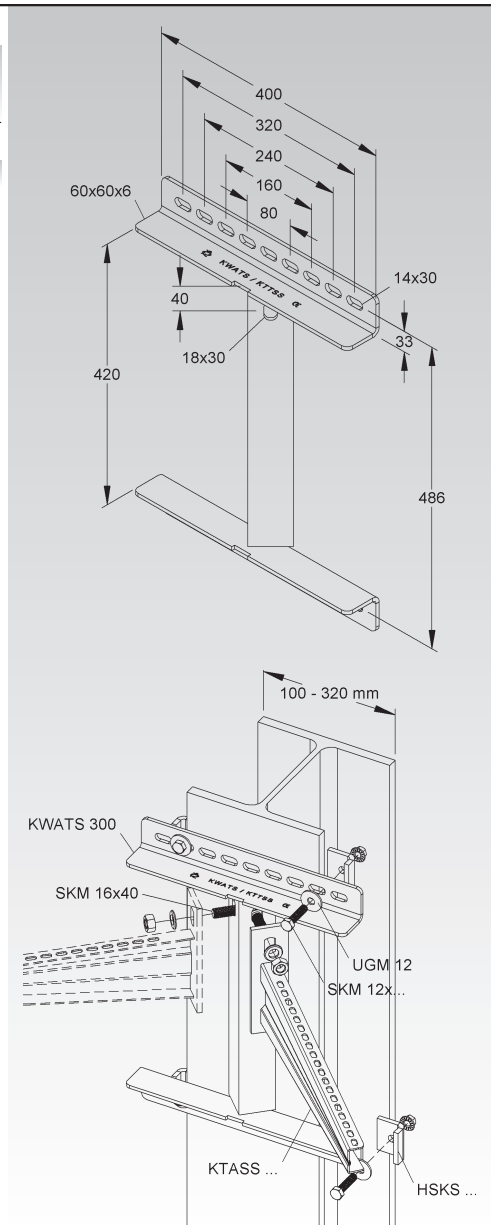

Clamping Bracket

extra heavy-duty version

	model no.	height H		length A		admissible load F at L/2 kN	admissible load F2 at L/2 kN	Weight per 100 pcs kg	Pack/Box Qty
		mm	Inch	mm	Inch				
F	KTTSS 200	156	6,1	230	9,1	10,00	10,0	318,22	1
F	KTTSS 300	156	6,1	330	13	10,00	10,0	346,13	1
F	KTTSS 400	181	7,1	430	16,9	9,36	10,0	387,32	1
F	KTTSS 500	181	7,1	530	20,9	8,89	10,0	421,06	1
F	KTTSS 600	206	8,1	630	24,8	8,53	10,0	504,28	1
F	KTTSS 700	206	8,1	730	28,7	7,37	8,0	551,82	1
F	KTTSS 800	231	9,1	830	32,7	6,55	7,0	613,21	1
F	KTTSS 900	231	9,1	930	36,6	6,28	6,5	667,74	1
F	KTTSS 1000	256	10,1	1030	40,6	5,69	6,0	736,13	1

for clamping to beams or for direct wall mount

The load rating shown is valid only when using HSKS... beam clamps with 8.8 grade M12 bolts.

Hardware not included. Please order beam clamps and bolts separately.

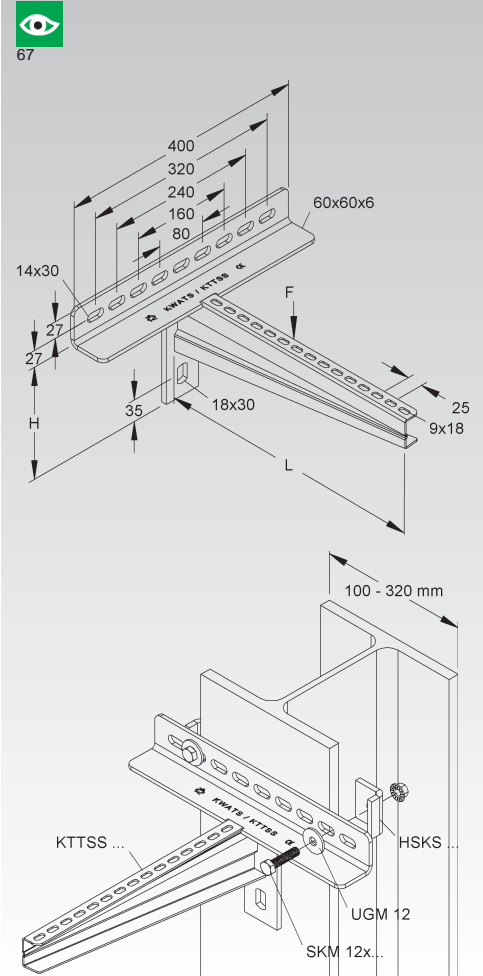

Beam Clamp

heavy-duty version

	model no.	height H		flange thickness t mm	Weight per 100 pcs kg	Pack/Box Qty
		mm	Inch			
F	HSKS 10	10	0,4	5 - 9	21	25
F	HSKS 15	15	0,6	10 - 14	25	25
F	HSKS 20	20	0,8	15 - 19	27	25
F	HSKS 25	25	1	20 - 24	33	25
F	HSKS 30	30	1,2	25 - 29	41	25
F	HSKS 35	35	1,4	30 - 34	49	25
F	HSKS 40	40	1,6	35 - 39	60	25

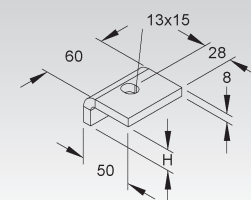
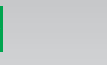

Hexagonal Bolt

serrated flange nut included

	model no.	thread M	length A		strength category	Weight per 100 pcs./pc. kg	Pack/Box Qty
			mm	Inch			
★	V SKM 12X50 V	12	50	2	10.9	7,00	20
★	V SKM 12X70 V	12	70	2,8	10.9	8,44	20
★	F SKM 12X50 F	12	50	2	10.9	8,27	20
★	F SKM 12X70 F	12	70	2,8	10.9	9,85	20

SKM 12..., tightening torque 123 Nm, 19 mm metric wrench



SUPPORT SYSTEM

Box/Wall Connector

	model no.	width B		Weight per 100 pcs kg	Pack/Box Qty
		mm	Inch		
S	WA 100	110	4,3	17,80	10
S	WA 150	160	6,3	25,71	10
S	WA 200	210	8,3	33,62	10
S	WA 250	260	10,2	41,52	10
S	WA 300	310	12,2	49,43	10
S	WA 400	410	16,1	64,61	10
S	WA 500	510	20,1	80,42	10
S	WA 600	610	24	96,24	10

for attaching cable tray to a box or a wall

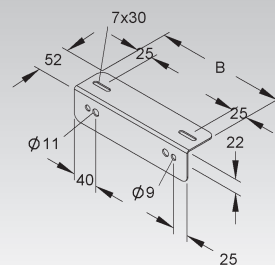

NOTES

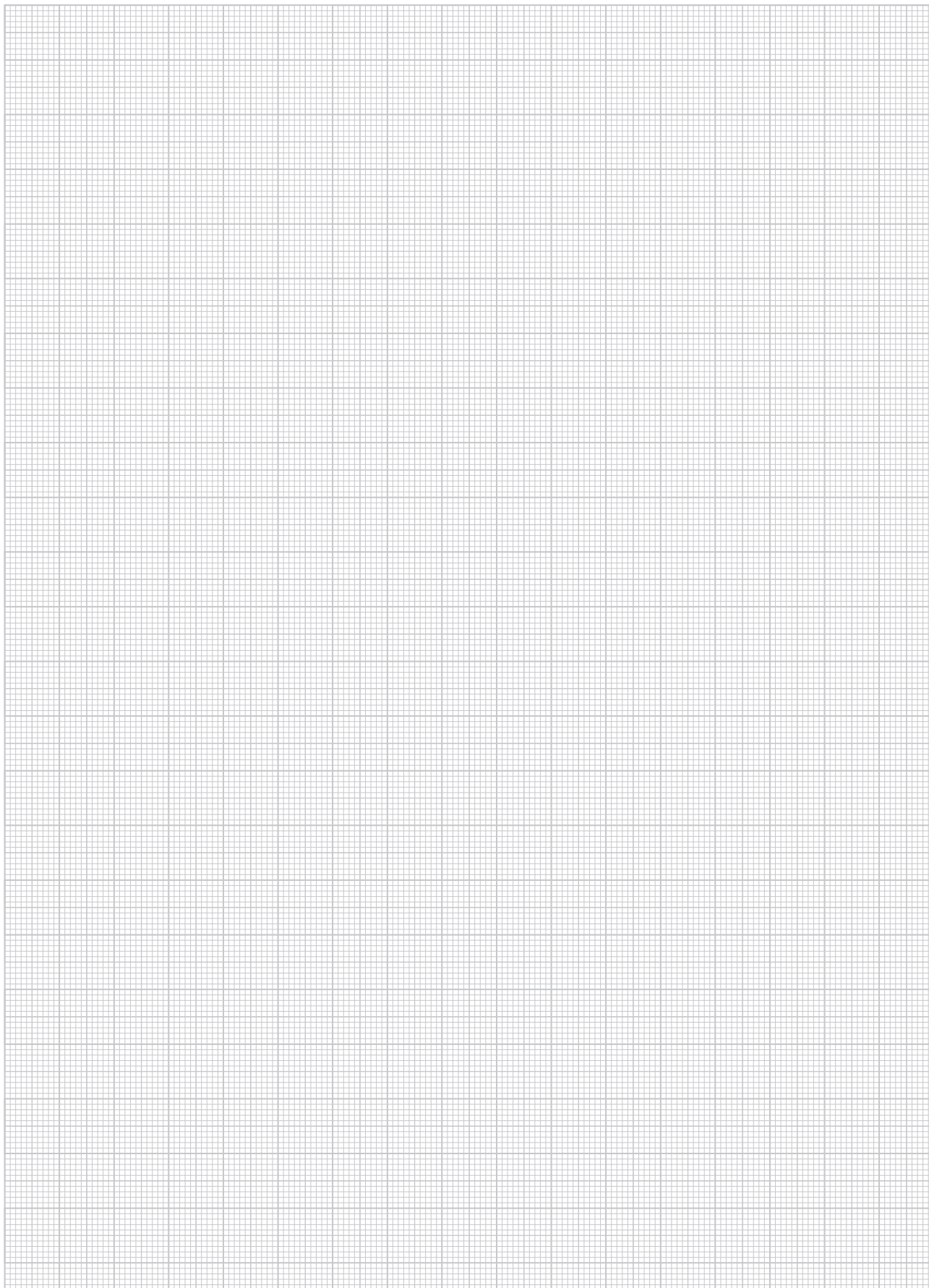
A large rectangular area filled with a fine grid of light gray lines, intended for taking notes. The grid consists of small squares, with a slightly larger square grid pattern overlaid on top.

System Overview Overhead Hanger HUF 50/...

SYSTEM	Overhead Hanger	HUF 50/...	Page 92
	Protective End Cap	K 50	Page 92
	Profile U 50	U 50/...	Page 93
	Straight Splice Plate	VB 50...	Page 93
	Head Plate	KU 50...	Page 93
	Head Plate	KUD 50...	Page 93
	Head Plate	KUGV 50...	Page 94
	Head Plate	KUGH 50...	Page 94
	Clamping Head Plate	KUDK 50...	Page 94
	Clamping Head Plate	KUGK 50...	Page 95
	Spacer	UD 24...	Page 95
	Bracket	KTUM...	Page 96
	Bracket	KTU...	Page 96

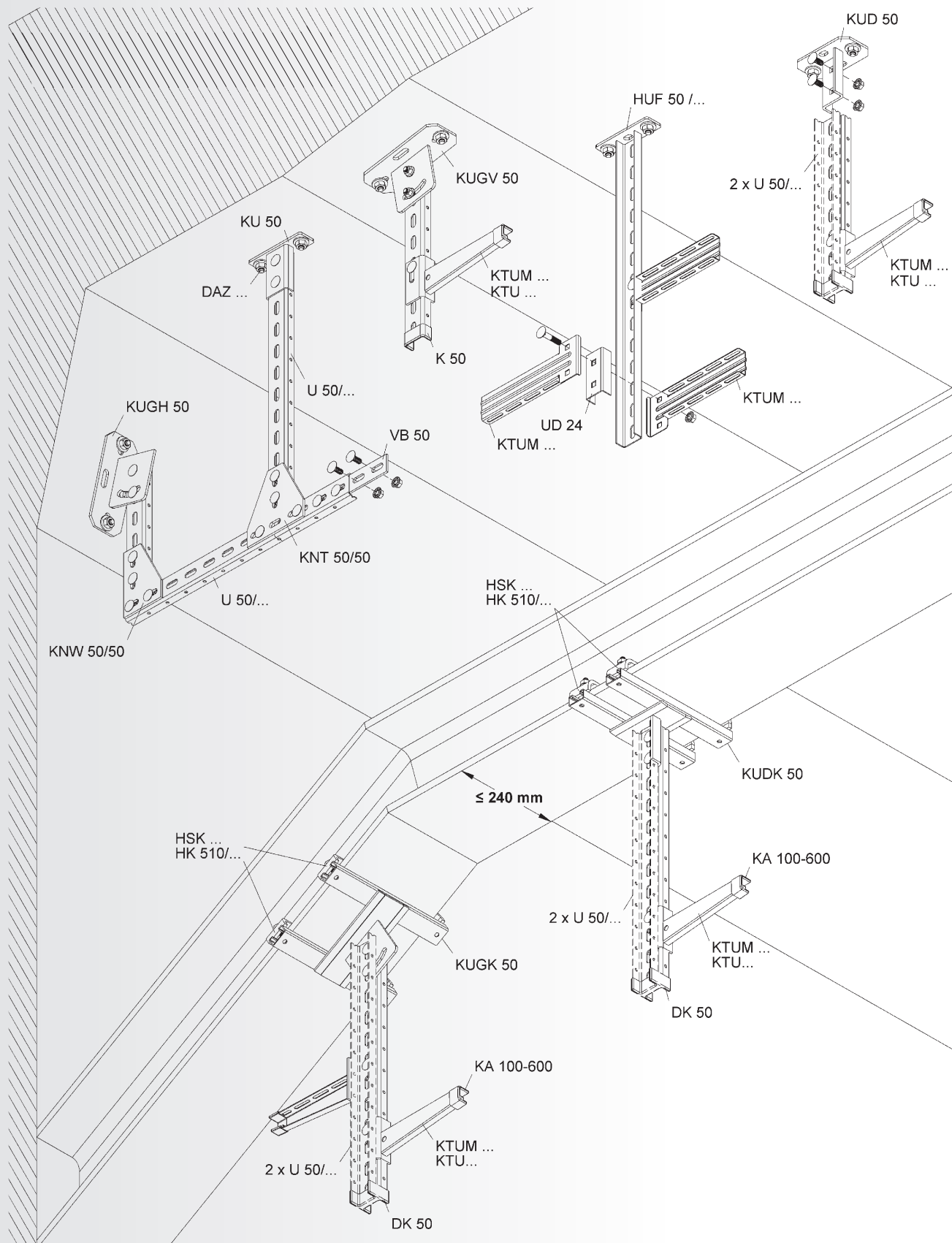

SUPPORT SYSTEM

Overhead Hanger

U-Profile

	model no.	Total length L		Weight per 100 pcs kg	Pack/Box Qty
		mm	Inch		
F	HUF 50/200	201	7,9	48,18	20
F	HUF 50/250	255	10	55,68	20
F	HUF 50/300	301	11,9	61,97	20
F	HUF 50/400	401	15,8	75,78	20
F	HUF 50/500	501	19,7	89,57	20
F	HUF 50/600	601	23,7	103,96	10
F	HUF 50/700	705	27,8	117,76	1
F	HUF 50/800	805	31,7	131,56	1
F	HUF 50/900	905	35,6	145,35	1
F	HUF 50/1000	1005	39,6	159,15	1
E3	HUF 50/200 E3	204	8	40,82	20
E3	HUF 50/300 E3	304	12	53,44	20
E3	HUF 50/400 E3	404	15,9	66,06	20
E3	HUF 50/500 E3	504	19,8	78,68	20
E3	HUF 50/600 E3	604	23,8	91,31	10
E3	HUF 50/700 E3	704	27,7	103,93	1
E3	HUF 50/800 E3	804	31,7	116,55	1
E3	HUF 50/900 E3	904	35,6	129,17	1
E3	HUF 50/1000 E3	1004	39,5	141,79	1

Suitable for: KTUM... and KTU... type brackets

The load rating shown is valid only for proper anchorage to the building structure. Please consult structural engineering for details and local regulations.

Load Chart: Deflection of Overhead Hanger (onesided load)

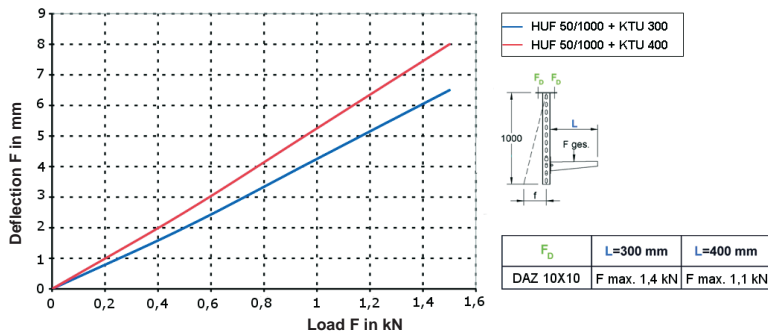

There is no noticeable deflection of the hanger for balanced (twosided) loading.



52

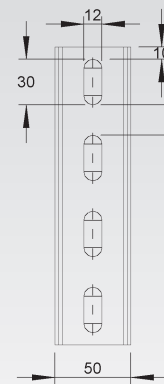
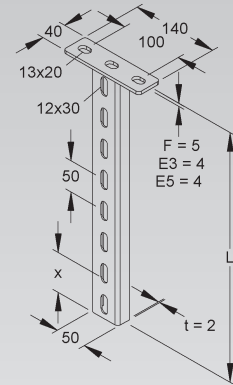

$I_x = 6,66 \text{ cm}^4$
 $I_y = 0,74 \text{ cm}^4$
 $W_x = 2,66 \text{ cm}^3$
 $W_y = 0,48 \text{ cm}^3$

Protective End Cap

model no.	color	Weight per 100 pcs kg	Pack/Box Qty	
K10	K 50	yellow	0,98	10

protective end cap

Suitable for: profile U 50/... and overhead hanger HUF 50/...



52

ca. 27 mm



Profile U 50

model no.	length A	Weight per 100 m kg	Pack/ Box Qty
	mm Inch		
S U 50/3000	3000 118,1	123,40	3 m
F U 50/3000 F	3000 118,1	135,74	3 m
E3 U 50/3000 E3	3000 118,1	126,22	3 m

for building customized overhead hangers, floorstands or support frames

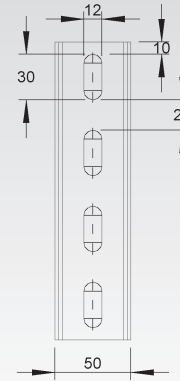
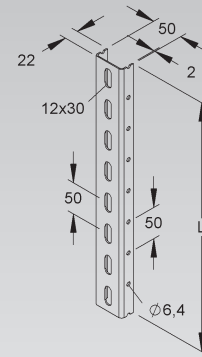

$$I_x = 6,66 \text{ cm}^4$$

$$I_y = 0,74 \text{ cm}^4$$

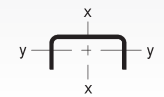

$$W_x = 2,66 \text{ cm}^3$$

$$W_y = 0,48 \text{ cm}^3$$

Straight Splice Plate

model no.	thick- ness t mm	Weight per 100 pcs kg	Pack/ Box Qty
F VB 50	4	22,0	20
E3 VB 50 E3	4	36,5	20

Suitable for: profile U 50/..., U 5050/... and overhead hanger HU 5050/...

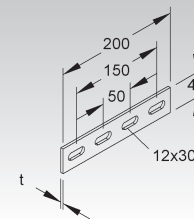

Head Plate

model no.	Total length L	thickness of the head plate t	Weight per 100 pcs kg	Pack/ Box Qty
	mm Inch	mm Inch		
F KU 50	105 4,1	5 0,2	41,90	20
E3 KU 50 E3	104 4,1	4 0,2	43,33	20

for mounting on horizontal ceilings

Suitable for: profile U 50/...

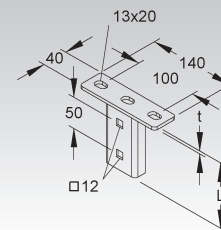

Head Plate

model no.	Total length L	thickness of the head plate t	Weight per 100 pcs kg	Pack/ Box Qty
	mm Inch	mm Inch		
F KUD 50	105 4,1	5 0,2	82,30	10
E3 KUD 50 E3	105 4,1	5 0,2	85,04	10

for mounting on horizontal ceilings

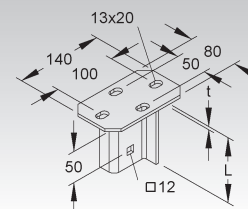

SUPPORT SYSTEM

Head Plate

vertical, adjustable from -30° to +30°

model no.	Total length L		thickness of the head plate t		Weight per 100 pcs kg	Pack/Box Qty
	mm	Inch	mm	Inch		
F KUGV 50	111	4,4	6	0,2	110,80	10
E3 KUGV 50 E3	111	4,4	6	0,2	111,73	10

for mounting on inclined ceilings

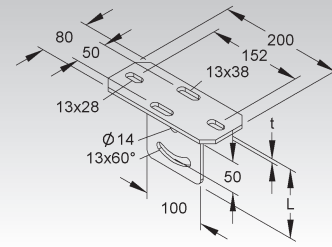

Head Plate

horizontal, adjustable from -30° to +30°

model no.	Total length L		thickness of the head plate t		Weight per 100 pc. kg	Pack/Box Qty
	mm	Inch	mm	Inch		
F KUGH 50	106	4,2	6	0,2	110,80	10
E3 KUGH 50 E3	106	4,2	6	0,2	111,73	10

for mounting on inclined ceilings

Suitable for: U 50/... Profile

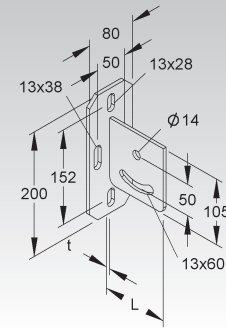

Clamping Head Plate

model no.	slot width	Total length L		thickness of the head plate t		Weight per 100 pcs kg	Pack/Box Qty
		mm	Inch	mm	Inch		
F KUDK 50	18	107	4,2	7	0,3	202,94	1
E3 KUDK 50 E3	18	107	4,2	7	0,3	186,80	1

for clamping to horizontal support beams (max. width 240 mm)

Suitable for: profile U 50/...

Installation mode: crosswise to the support beam

Hardware not included. Please order beam clamps and bolts separately.

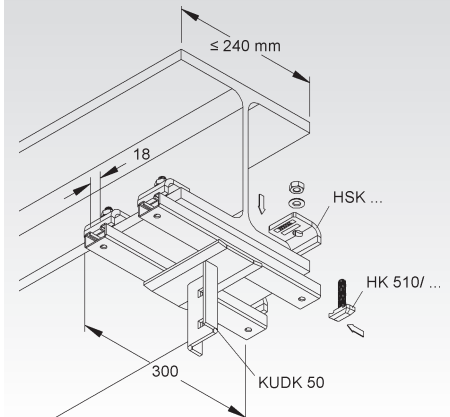
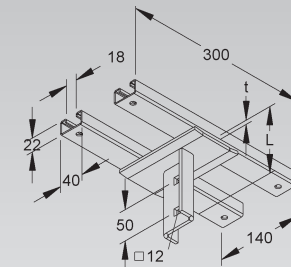

Clamping Head Plate

adjustable from -30° to +30°

model no.	slot width	Total length L	thickness of the head plate t		Weight per 100 pcs kg	Pack/Box Qty
	mm Inch		mm Inch	mm Inch		
F KUGK 50	18 0,7	113 4,4	8 0,3	8 0,3	237,21	1
E3 KUGK 50 E3	18 0,7	113 4,4	8 0,3	8 0,3	218,10	1

for clamping U-profiles to support beams (max. width 240 mm), horizontally adjustable

Suitable for: profile U 50/...

Installation mode: crosswise to the support beam

Hardware not included. Please order beam clamps and bolts separately.

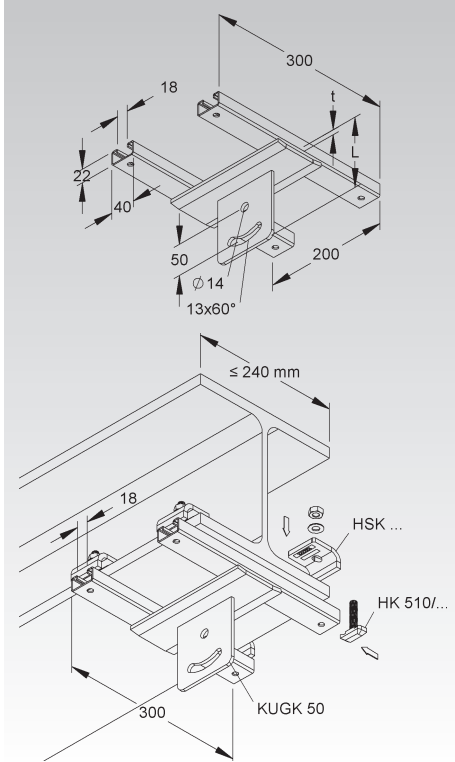

Spacer

model no.	Weight per 100 kg	Pack/Box Qty
E3 UD 24 E3	18,48	20

Suitable for: making a double sided bracket from two KTUM... brackets on an HUF 50/... hanger

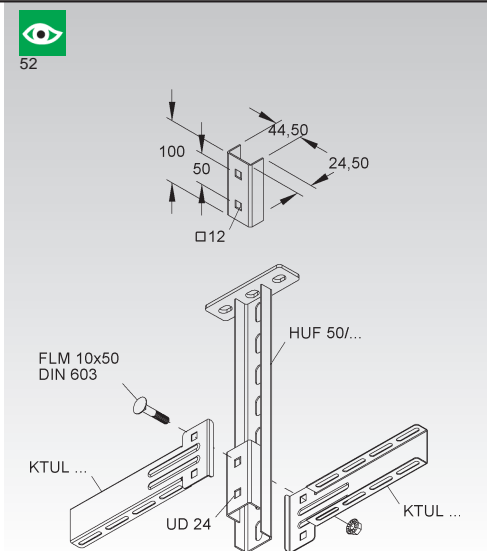

SUPPORT SYSTEM

Bracket

medium duty

model no.	height H		length A		admissible load F at L/2 kN	Weight per 100 pcs kg	Pack/Box Qty
	mm	Inch	mm	Inch			
S KTUM 100	73	2,9	105	4,1	1,2	21,45	20
S KTUM 150	73	2,9	155	6,1	1,2	26,27	20
S KTUM 200	73	2,9	205	8,1	1,2	31,08	20
S KTUM 300	73	2,9	305	12	1,2	46,86	20
S KTUM 400	83	3,3	405	15,9	1,2	73,28	20
F KTUM 100 F	73	2,9	105	4,1	1,2	22,93	20
F KTUM 150 F	73	2,9	155	6,1	1,2	28,23	20
F KTUM 200 F	73	2,9	205	8,1	1,2	33,52	20
F KTUM 300 F	73	2,9	305	12	1,2	50,88	20
F KTUM 400 F	83	3,3	405	15,9	1,2	79,94	20
E3 KTUM 100 E3	73	2,9	105	4,1	1,2	21,51	20
E3 KTUM 200 E3	73	2,9	205	8,1	1,2	31,20	20
E3 KTUM 300 E3	83	3,3	305	12	1,2	59,58	20
E3 KTUM 400 E3	83	3,3	405	15,9	1,2	73,67	20

Suitable for: overhead hanger HUF 50/...

The load rating shown is valid only for proper anchorage to the building structure.



52

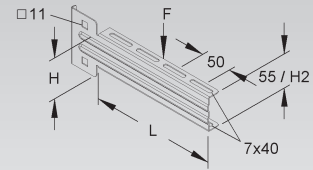

Bracket for HUF Profiles and Square Tubes

heavy duty

model no.	height H		length A		admissible load F at L/2 kN	Weight per 100 kg	Pack/Box Qty
	mm	Inch	mm	Inch			
F KTU 100	50	2	110	4,3	2,5	32,40	20
F KTU 150	50	2	160	6,3	2,5	35,79	20
F KTU 200	60	2,4	210	8,3	2,5	45,34	20
F KTU 250	60	2,4	260	10,2	2,5	50,00	20
F KTU 300	75	3	310	12,2	2,5	74,00	20
F KTU 400	75	3	410	16,1	2,5	88,60	20
F KTU 500	90	3,5	510	20,1	2,5	124,57	10
F KTU 600	90	3,5	610	24	2,5	140,99	10

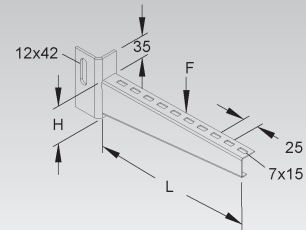

NOTES

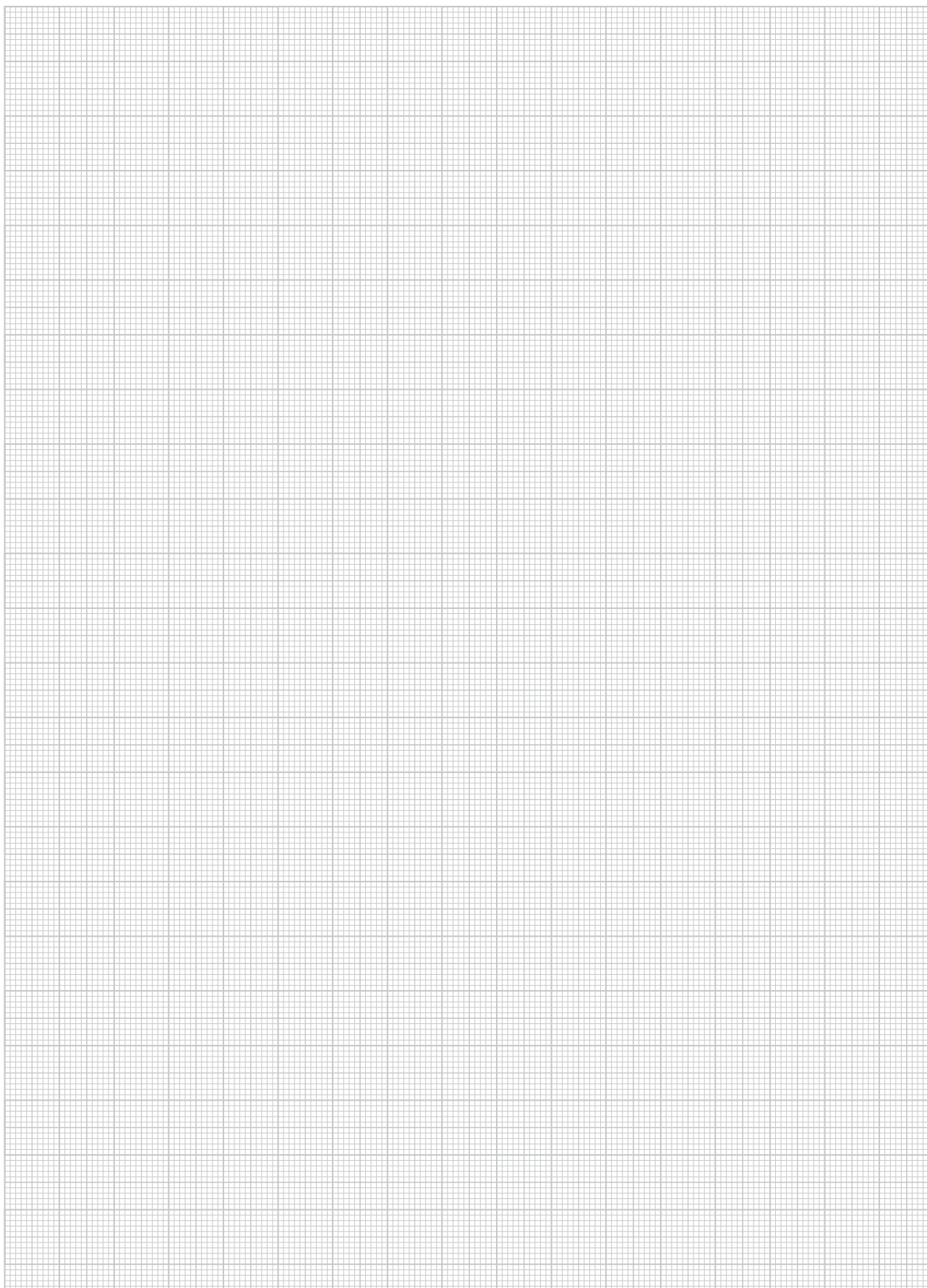
A large rectangular area filled with a fine grid of small squares, intended for taking notes. The grid lines are light gray and form a consistent pattern across the page.

System Overview Overhead Hanger HU 5050/...

SYSTEM	Overhead Hanger	HU 5050/...	Page 100
	Protective End Cap	K 5050	Page 100
	Profile U 5050	U 5050/...	Page 101
	Straight Splice Plate	VB 50...	Page 101
	Spacer for Overhead Hanger	HDS 50.50 F	Page 101
	Head Plate	KU 5050	Page 102
	Head Plate	KUGV 5050	Page 102
	Clamping Head Plate	KUDK 5050	Page 102
	Clamping Head Plate	KUGPK 5050	Page 103
	Bracket	KTAM...	Page 103
	Bracket	KTA...	Page 103

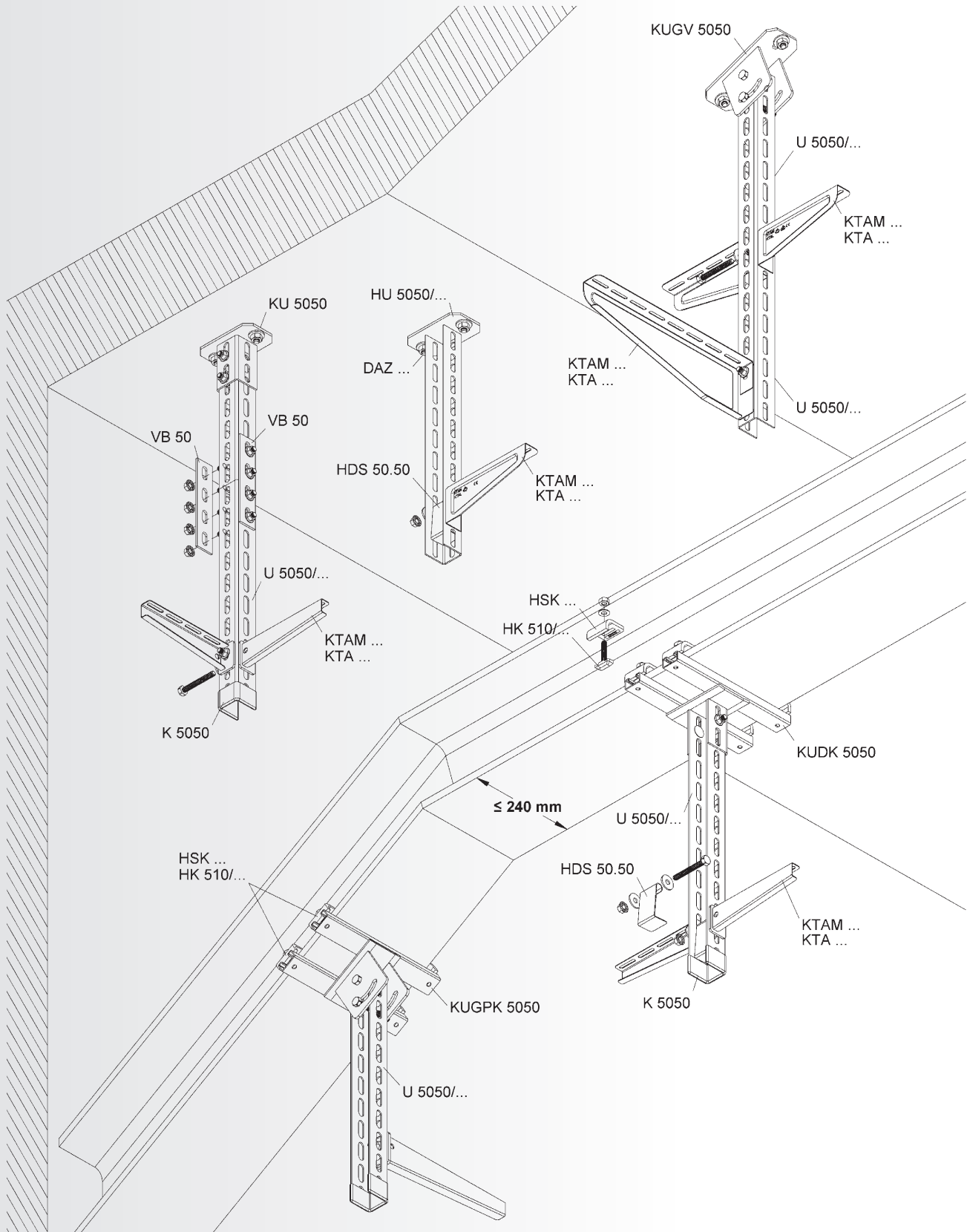

SUPPORT SYSTEM

Overhead Hanger

U-Profile

	model no.	Total length L		Weight per 100 pcs kg	Pack/Box Qty
		mm	Inch		
F	HU 5050/200	205	8,1	93,08	1
F	HU 5050/250	255	10	105,23	1
F	HU 5050/300	305	12	117,38	1
F	HU 5050/400	405	15,9	141,68	1
F	HU 5050/500	505	19,9	165,97	1
F	HU 5050/600	605	23,8	190,27	1
F	HU 5050/700	705	27,8	214,57	1
F	HU 5050/800	805	31,7	238,87	1
F	HU 5050/900	905	35,6	263,17	1
F	HU 5050/1000	1005	39,6	287,46	1
F	HU 5050/1200	1205	47,4	336,06	1
F	HU 5050/1500	1505	59,3	408,95	1
F	HU 5050/2000	2005	78,9	530,44	1

Please use the HDS... spacer kit to avoid deformation of the U-profile when installing KTA... brackets. Slotted hole size 13x40 mm, 50 mm pitch. The load rating shown is valid only for proper anchorage to the building structure. Please consult structural engineering for details and local regulations.

Load Chart: Deflection of Overhead Hanger (onesided load)

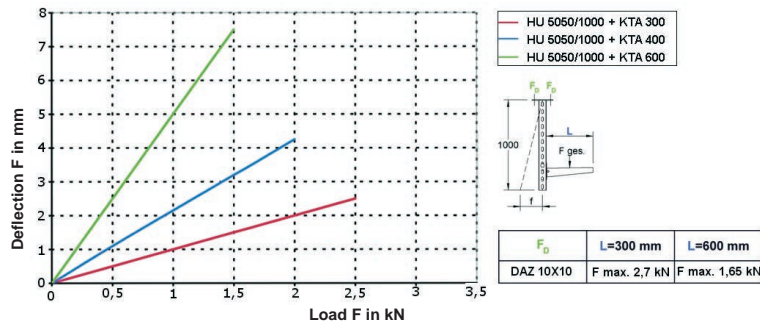

There is no noticeable deflection of the hanger for balanced (twosided) loading.

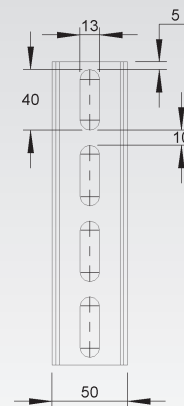
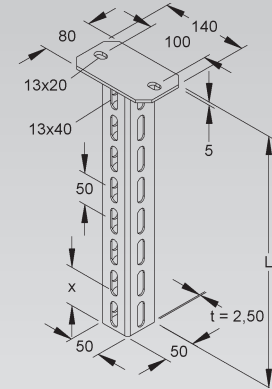
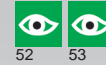

$$\begin{aligned}
 I_x &= 12,10 \text{ cm}^4 & I_y &= 8,14 \text{ cm}^4 & W_x &= 4,84 \text{ cm}^3 & W_y &= 2,57 \text{ cm}^3
 \end{aligned}$$

Protective End Cap

model no.	color	Weight per 100 pcs kg	Pack/Box Qty
K10	K 5050 yellow	3	10

protective end cap

Suitable for: profile U 5050/... and overhead hanger HU 5050/...

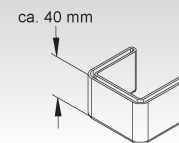

Profile U 5050

	model no.	length A		Weight per 100 pcs/m kg	Pack/ Box Qty
		mm	Inch		
F	U 5050/1000 F	1000	39,4	242,98	1
F	U 5050/1500 F	1500	59,1	364,47	1
F	U 5050/2000 F	2000	78,7	242,98	2 m
F	U 5050/3000 F	3000	118,1	242,98	3 m
F	U 5050/6000 F	6000	236,2	242,98	6 m

for building customized overhead hangers, floorstands or support frames
Slotted hole size 13x40 mm, 50 mm pitch.

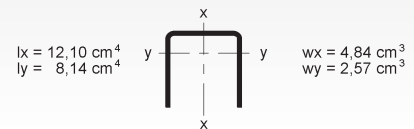
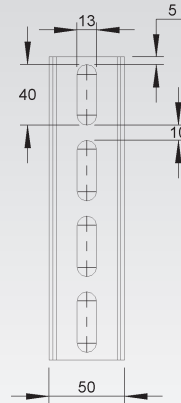
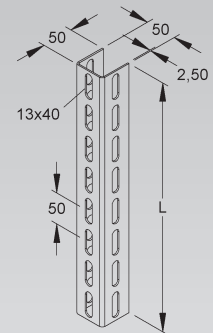

Straight Splice Plate

	model no.	thick- ness t mm	Weight per 100 pcs kg	Pack/ Box Qty
F	VB 50	4	22,0	20
E3	VB 50 E3	4	36,5	20
E5	VB 50 E5	4	36,3	20

Suitable for: profile U 50/..., U 5050/... and overhead hanger HU 5050/...

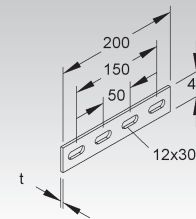

Spacer for Overhead Hanger

	model no.	Weight per 100 pcs kg	Pack/ Box Qty
F	HDS 50.50 F	16,52	50

Suitable for: profile U 5050/... and overhead hanger HU 5050/...
Please use the HDS... spacer kit to avoid deformation of the U-profile when installing KTA... brackets.

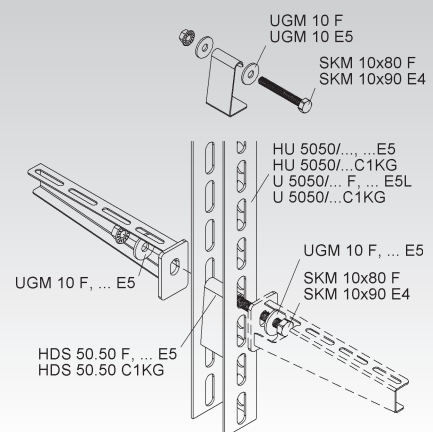

SUPPORT SYSTEM

Head Plate

model no.	Total length L mm Inch	thickness of the head plate t mm Inch	Weight per 100 pcs kg	Pack/Box Qty
F KU 5050	105 4,1	5 0,2	84,56	1

for mounting on horizontal ceilings

Suitable for: profile U 5050/...

Slotted hole size 13x40 mm, 50 mm pitch.



52

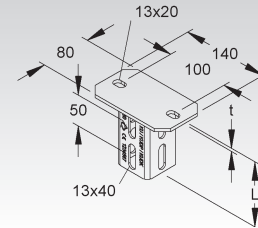

Head Plate

vertical, adjustable from -30° to +30°

model no.	Total length L mm Inch	thickness of the head plate t mm Inch	Weight per 100 pcs kg	Pack/Box Qty
F KUGV 5050	111 4,4	6 0,2	155,5	1

for mounting on inclined ceilings

Suitable for: profile U 5050/...

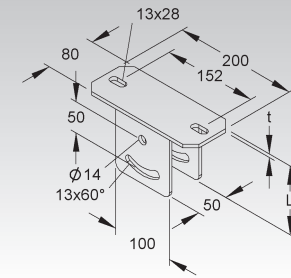

Clamping Head Plate

model no.	slot width mm Inch	Total length L mm Inch	thickness of the head plate t mm Inch	Weight per 100 pcs kg	Pack/Box Qty
F KUDK 5050	18 0,7	107 4,2	7 0,3	193,35	1

for clamping to horizontal support beams (max. width 240 mm)

Suitable for: profile U 5050/...

Slotted hole size 12x40 mm, 50 mm pitch.

Installation mode: crosswise to the support beam

Hardware not included. Please order beam clamps and bolts separately.

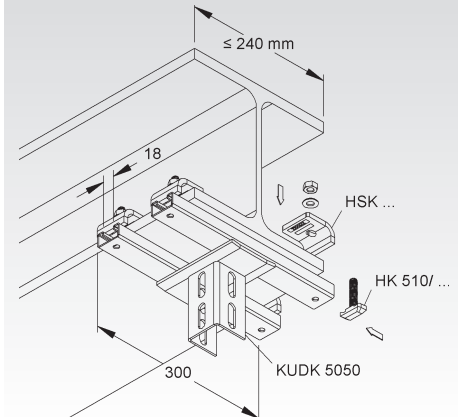
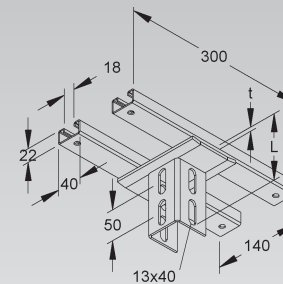

Clamping Head Plate

adjustable from -30° to +30°

model no.	slot width		Total length L		thickness of the head plate t		Weight per 100 pcs kg	Pack/Box Qty
	mm	Inch	mm	Inch	mm	Inch		
F KUGPK 5050	18	0,7	112	4,4	7	0,3	247,21	1

for clamping U-profiles to support beams (max. width 240 mm), horizontally adjustable

Suitable for: profile U 5050/...

Installation mode: crosswise to the support beam

Hardware not included. Please order beam clamps and bolts separately.

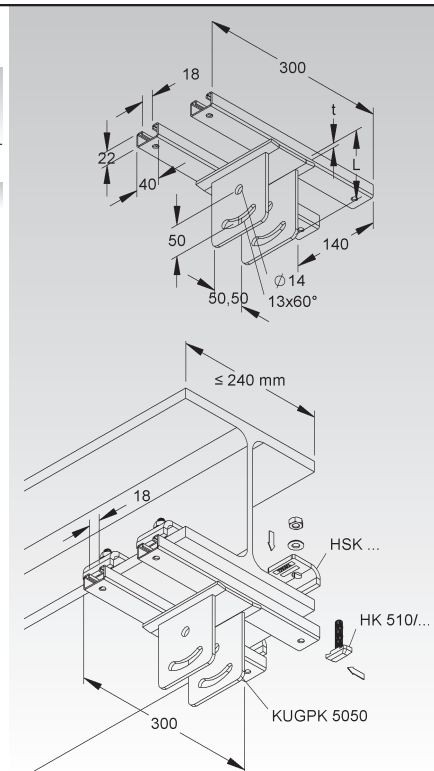

Bracket

medium duty

model no.	height H		length A		admissible load F at L/2 kN	Weight per 100 pcs/kg	Pack/Box Qty
	mm	Inch	mm	Inch			
S KTAM 100	60	2,4	110	4,3	1,2	16,41	20
S KTAM 150	60	2,4	160	6,3	1,2	21,94	20
S KTAM 200	80	3,1	210	8,3	1,2	30,27	20
S KTAM 250	80	3,1	260	10,2	1,2	36,98	20
S KTAM 300	82	3,2	320	12,6	1,5	44,20	20
S KTAM 400	82	3,2	420	16,5	1,5	50,28	20
F KTAM 100 F	60	2,4	110	4,3	1,2	17,76	20
F KTAM 150 F	60	2,4	160	6,3	1,2	23,84	20
F KTAM 200 F	80	3,1	210	8,3	1,2	33,01	20
F KTAM 250 F	80	3,1	260	10,2	1,2	40,39	20
F KTAM 300 F	82	3,2	320	12,6	1,5	48,38	20
F KTAM 400 F	82	3,2	420	16,5	1,5	55,27	20

for mounting to overhead hangers or for direct wall mount

The load rating shown is valid only for proper anchorage to the building structure.

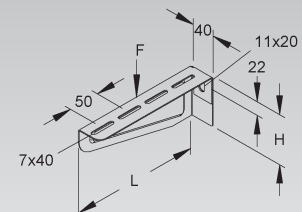

Bracket

medium-duty

model no.	height H		width B		length A		admissible load F at L/2 kN	Weight per 100 pcs kg	Pack/Box Qty
	mm	Inch	mm	Inch	mm	Inch			
F KTA 100	45	1,8	40	1,6	110	4,3	2,5	15,66	20
F KTA 150	45	1,8	40	1,6	160	6,3	2,5	19,05	20
F KTA 200	55	2,2	40	1,6	210	8,3	2,5	27,55	20
F KTA 250	55	2,2	40	1,6	260	10,2	2,5	32,21	20
F KTA 300	65	2,6	50	2	310	12,2	2,5	59,17	20
F KTA 350	65	2,6	50	2	360	14,2	2,5	66,35	20
F KTA 400	75	3	50	2	410	16,1	2,5	79,17	20
F KTA 450	75	3	50	2	460	18,1	2,5	88,02	10
F KTA 500	90	3,5	50	2	510	20,1	2,5	111,06	10
F KTA 550	90	3,5	50	2	560	22	2,5	134,20	10
F KTA 600	90	3,5	50	2	610	24	2,5	127,48	10

The load rating shown is valid only for proper anchorage to the building structure. Please consult structural engineering for details and local regulations.

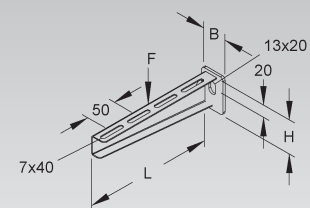

System Overview Overhead Hanger HU 6040/...

SYSTEM	Overhead Hanger	HU 6040/...	Page 106
	Protective End Cap	SKU 6040	Page 106
	Profile U 6040	U 6040/...	Page 107
	Straight Splice Plate	VB 6040...	Page 107
	Spacer for Overhead Hanger	HDS 60.40...	Page 108
	Head Plate	KU 6040...	Page 108
	Clamping Head Plate	KUDK 6040	Page 108
	Clamping Head Plate	KUGPK 6040	Page 109
	Bracket	KTAS...	Page 109

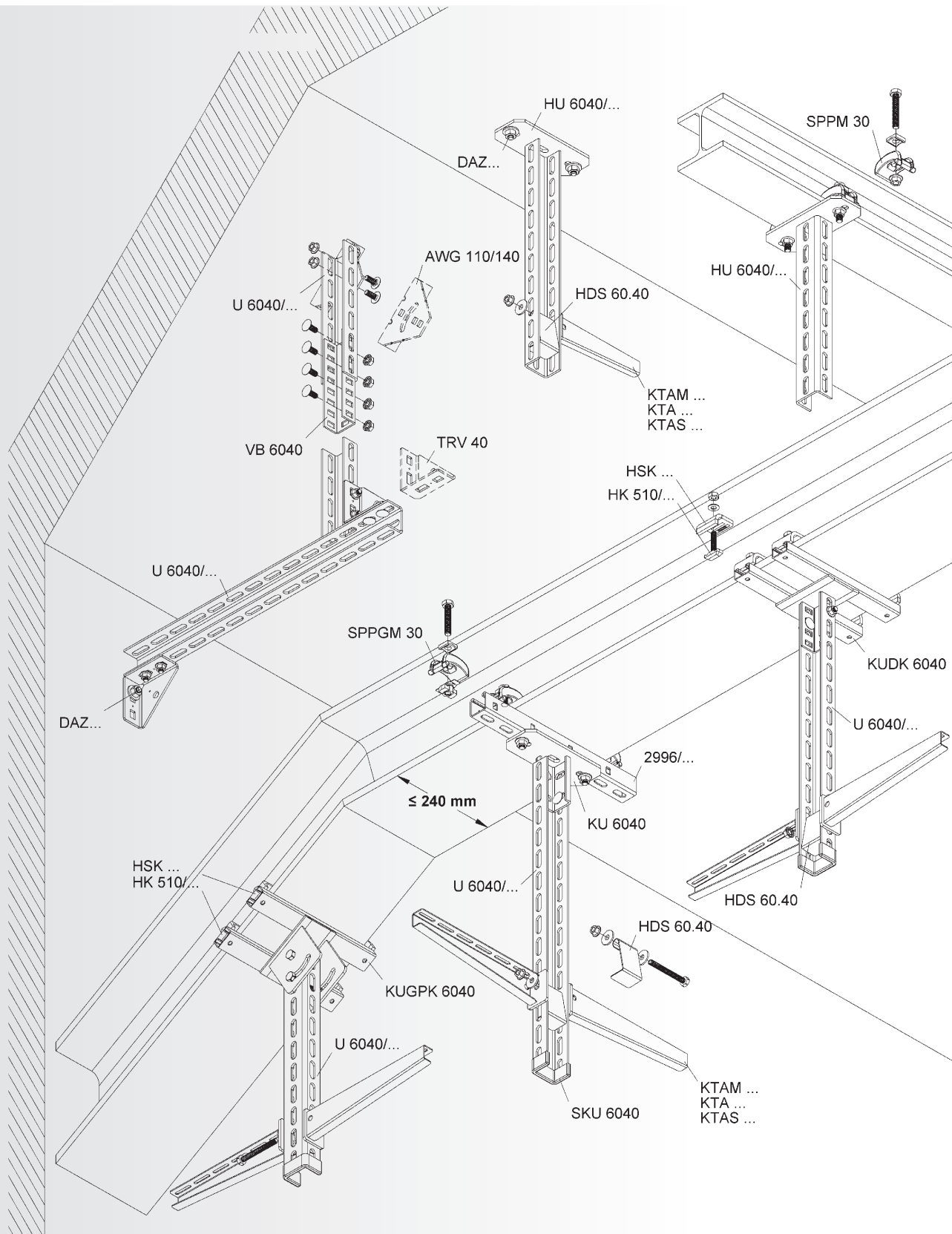

SUPPORT SYSTEM

Overhead Hanger

U-Profile

	model no.	Total length L		Weight per 100 pcs kg	Pack/Box Qty
		mm	Inch		
F	HU 6040/200	206	8,1	143,21	1
F	HU 6040/250	256	10,1	160,14	1
F	HU 6040/300	306	12	177,08	1
F	HU 6040/400	406	16	210,95	1
F	HU 6040/500	506	19,9	244,82	1
F	HU 6040/600	606	23,9	278,67	1
F	HU 6040/700	706	27,8	312,54	1
F	HU 6040/800	806	31,7	346,41	1
F	HU 6040/900	906	35,7	380,28	1
F	HU 6040/1000	1006	39,6	414,15	1
F	HU 6040/1200	1206	47,5	481,89	1
F	HU 6040/1500	1506	59,3	583,50	1
F	HU 6040/2000	2006	79	752,83	1
E3	HU 6040/200 E3	206	8,1	131,02	1
E3	HU 6040/250 E3	256	10,1	146,51	1
E3	HU 6040/300 E3	306	12	162,00	1
E3	HU 6040/400 E3	406	16	192,99	1
E3	HU 6040/500 E3	506	19,9	223,97	1
E3	HU 6040/600 E3	606	23,9	254,96	1
E3	HU 6040/700 E3	706	27,8	285,94	1
E3	HU 6040/800 E3	806	31,7	316,93	1
E3	HU 6040/900 E3	906	35,7	347,91	1
E3	HU 6040/1000 E3	1006	39,6	378,90	1
E3	HU 6040/1200 E3	1206	47,5	440,87	1
E3	HU 6040/1500 E3	1506	59,3	533,83	1
E3	HU 6040/2000 E3	2006	79	688,75	1

Suitable for: KTAM... and KTA... brackets

Please use the HDS... spacer kit to avoid deformation of the U-profile when installing KTA... brackets.

Slotted hole size 13x40 mm, 50 mm pitch.

The load rating shown is valid only for proper anchorage to the building structure. Please consult structural engineering for details and local regulations.

Load Chart: Deflection of Overhead Hanger (onesided load)

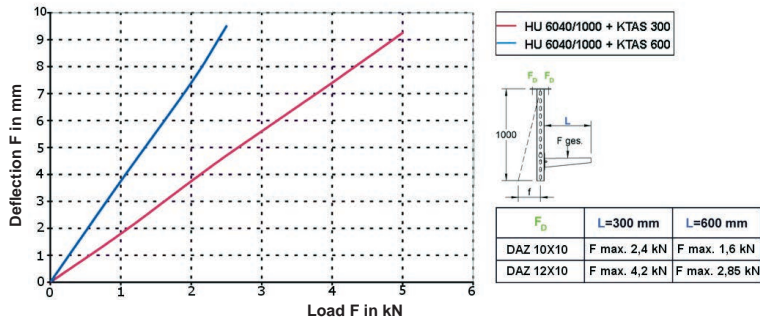

There is no noticeable deflection of the hanger for balanced (twosided) loading.



53

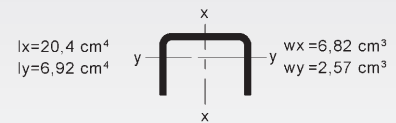
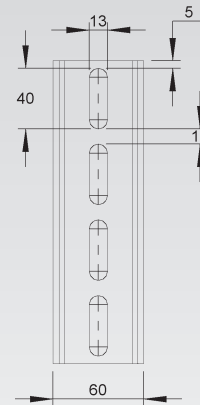
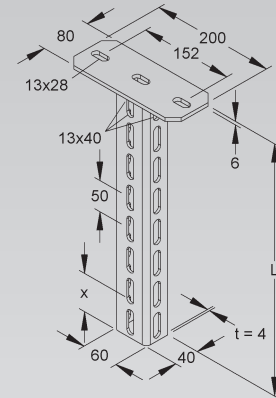

Protective End Cap

model no.	color	Weight per 100 pcs kg	Pack/Box Qty
K03 SKU 6040	yellow	1,32	20

protective end cap

Suitable for: profile U 6040/... and overhead hanger HU 6040/...

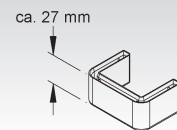

Profile U 6040

model no.		length A	Weight per 100 pcs/m kg	Pack/ Box Qty
		mm Inch		
F	U 6040/1000 F	1000 39,4	338,68	1
F	U 6040/1500 F	1500 59,1	508,02	1
F	U 6040/2000 F	2000 78,7	338,68	2 m
F	U 6040/3000 F	3000 118,1	338,68	3 m
F	U 6040/6000 F	6000 236,2	338,68	6 m
E3	U 6040/1000 E3	1000 39,4	309,85	1
E3	U 6040/1500 E3	1500 59,1	464,78	1
E3	U 6040/2000 E3	2000 78,7	309,86	2 m
E3	U 6040/3000 E3	3000 118,1	309,85	3 m
E3	U 6040/6000 E3	6000 236,2	309,85	6 m

for building customized overhead hangers, floorstands or support frames



52

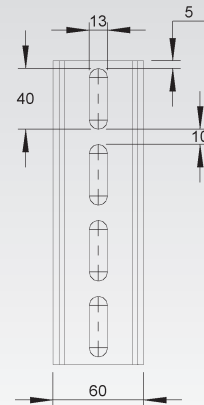
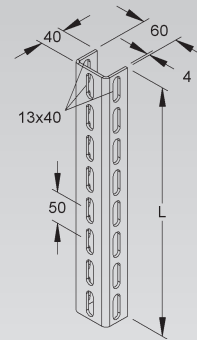

$$\begin{aligned}
 I_x &= 20,4 \text{ cm}^4 & w_x &= 6,82 \text{ cm}^3 \\
 I_y &= 6,92 \text{ cm}^4 & w_y &= 2,57 \text{ cm}^3
 \end{aligned}$$

Straight Splice Plate

model no.	Weight per 100 pcs kg	Pack/ Box Qty
F VB 6040	61,20	10
E3 VB 6040 E3	57,63	10

Suitable for: profile U 6040/...
Slotted hole size 11x18 mm, 50 mm pitch.

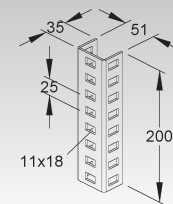

Spacer for Overhead Hanger

model no.	Weight per 100 pcs kg	Pack/Box Qty
F HDS 60.40 F	18,59	50
E3 HDS 60.40 E3	17,25	50

Suitable for: profile U 6040/... and overhead hanger HU 6040/...
Please use the HDS... spacer kit to avoid deformation of the U-profile when installing KTA... brackets.

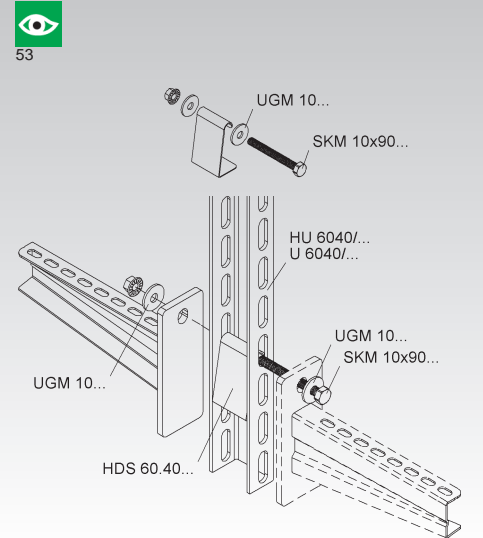

Head Plate

model no.	Total length L mm Inch	thickness of the head plate t mm Inch	Weight per 100 pcs kg	Pack/Box Qty
F KU 6040	106 4,2	6 0,2	118,01	1
E3 KU 6040 E3	106 4,2	6 0,2	108,63	1

for mounting on horizontal ceilings

Suitable for: profile U 6040/...

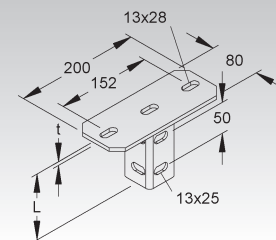

Clamping Head Plate

model no.	slot width mm Inch	Total length L mm Inch	thickness of the head plate t mm Inch	Weight per 100 pcs kg	Pack/Box Qty
F KUDK 6040	18 0,7	107 4,2	7 0,3	184,34	1

for clamping to horizontal support beams (max. width 240 mm)

Suitable for: profile U 6040/...

Slotted hole size 11x18 mm, 50 mm pitch.

Installation mode: crosswise to the support beam

Hardware not included. Please order beam clamps and bolts separately.

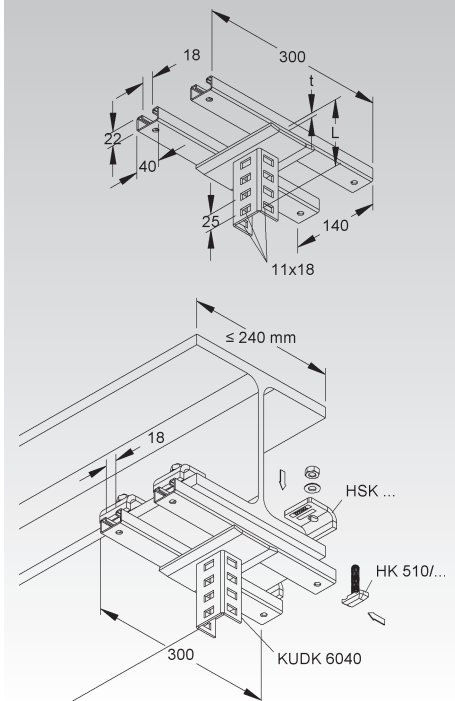

Clamping Head Plate

adjustable from -30° to +30°

model no.	slot width		Total length L		thickness of the head plate t mm Inch	Weight per 100 pcs kg	Pack/Box Qty	
	mm	Inch	mm	Inch				
F KUGPK 6040	18	0,7	112	4,4	7	0,3	248,71	1

for clamping U-profiles to support beams (max. width 240 mm), horizontally adjustable

Suitable for: profile U 6040/...

Installation mode: crosswise to the support beam

Hardware not included. Please order beam clamps and bolts separately.

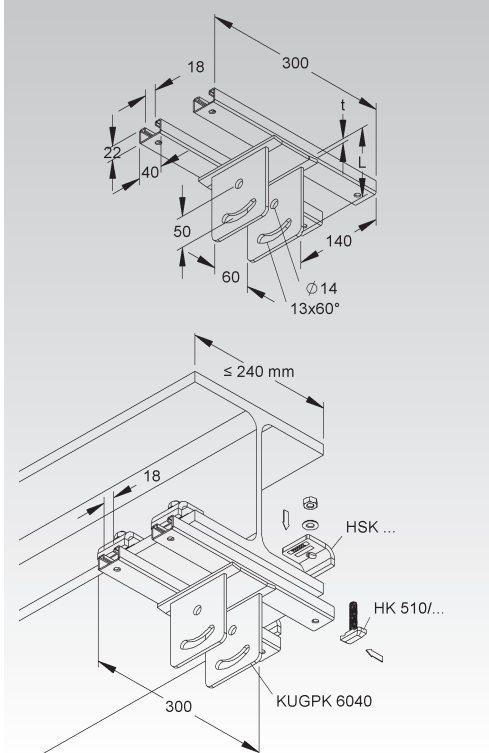

Bracket

heavy-duty

model no.	height H		length A		admissible load F at L/2 kN	Weight per 100 pcs kg	Pack/Box Qty
	mm	Inch	mm	Inch			
F KTAS 100	113	4,4	130	5,1	5	90,05	1
F KTAS 200	113	4,4	230	9,1	5	108,56	1
F KTAS 300	113	4,4	330	13	5	130,86	1
F KTAS 400	113	4,4	430	16,9	5	155,49	1
F KTAS 500	150	5,9	530	20,9	5	197,79	1
F KTAS 600	150	5,9	630	24,8	5	227,10	1
F KTAS 700	150	5,9	730	28,7	5	303,33	1
F KTAS 800	195	7,7	830	32,7	5	364,47	1
F KTAS 900	195	7,7	930	36,6	5	409,88	1
F KTAS 1000	195	7,7	1030	40,6	5	458,21	1
E3 KTAS 200 E3	113	4,4	230	9,1	5	99,32	1
E3 KTAS 300 E3	113	4,4	330	13	5	119,72	1
E3 KTAS 400 E3	113	4,4	430	16,9	5	142,25	1
E3 KTAS 500 E3	150	5,9	530	20,9	5	181,00	1
E3 KTAS 600 E3	150	5,9	630	24,8	5	207,76	1

for mounting to overhead hangers or for direct wall mount

The load rating shown is valid only for proper anchorage to the building structure. Please consult structural engineering for details and local regulations.

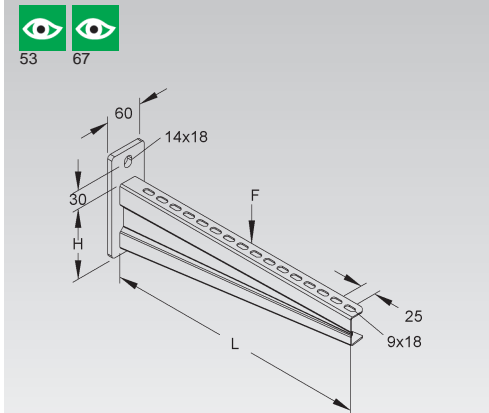

System Overview Overhead Hanger HI 80/...

SYSTEM	Overhead Hanger	HI 80/...	Page 112
	Protective End Cap	SKI 80	Page 112
	Profile I 80	I 80/...	Page 113
	Straight Spice Plate	VBI 80	Page 113
	Tee Connector	VBIQ 80/140	Page 113
	Two Hole Corner Angle for I 80	WWI 80	Page 114
	Head Plate	KI 80	Page 114
	Head Plate Extender Device	KIA 80	Page 114
	Head Plate	KIQ 80	Page 114
	Head Plate	KIGV 80	Page 114
	Head Plate	KIGVQ 80	Page 115
	Clamping Head Plate	KIDK 80	Page 115
	Clamping Head Plate	KIDP 80	Page 116
	Bracket	KTT...	Page 116
	Protective End Cap	KA 100-600	Page 116
	Bracket	KTTS...	Page 117



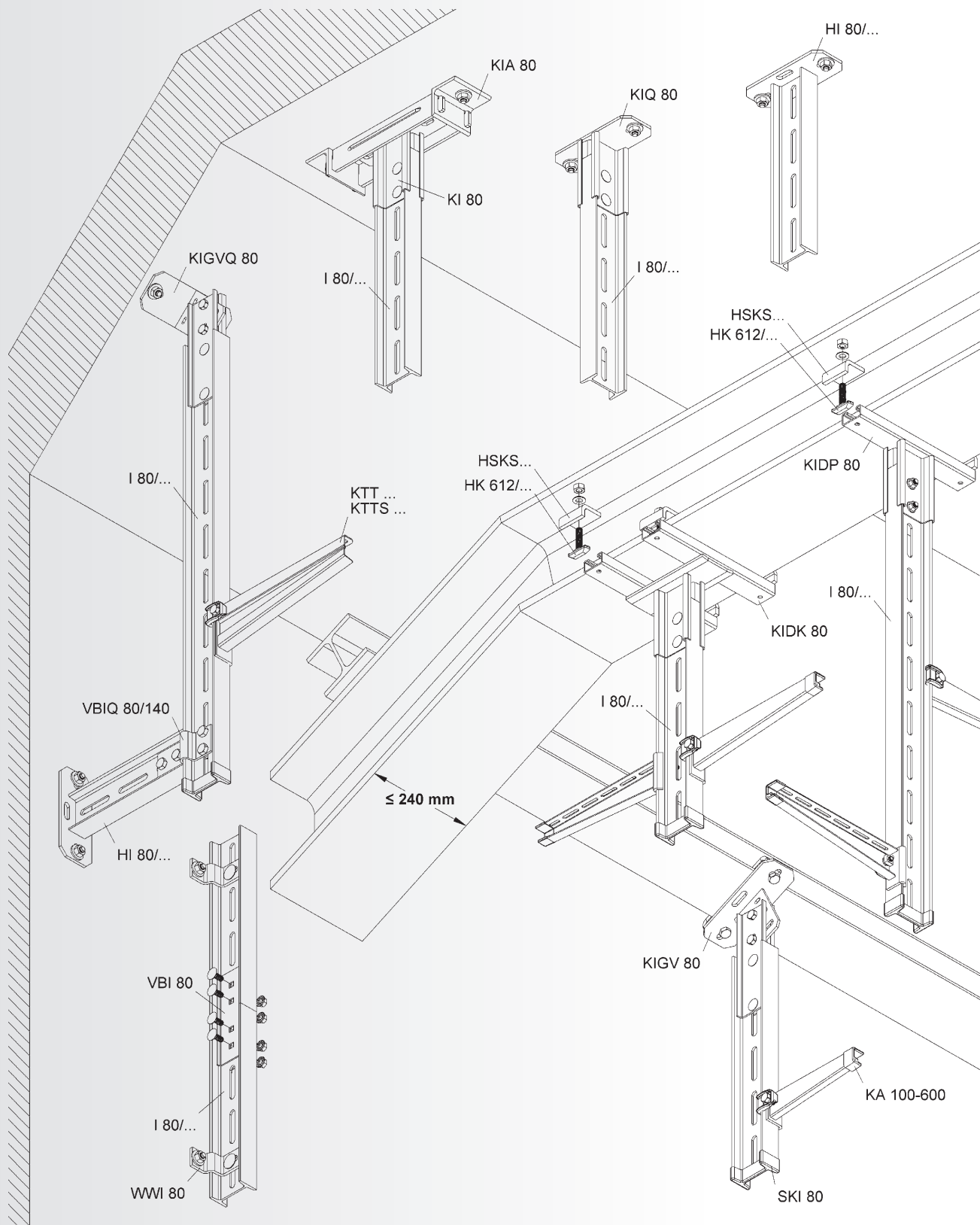

SUPPORT SYSTEM

Overhead Hanger

I 80 profile

	model no.	Total length L		Weight per 100 pcs kg	Pack/Box Qty
		mm	Inch		
F	HI 80/200	206	8,1	196,89	1
F	HI 80/300	306	12	259,12	1
F	HI 80/400	406	16	321,35	1
F	HI 80/500	506	19,9	383,58	1
F	HI 80/600	606	23,9	445,81	1
F	HI 80/700	706	27,8	508,04	1
F	HI 80/800	806	31,7	570,27	1
F	HI 80/900	906	35,7	632,50	1
F	HI 80/1000	1006	39,6	694,73	1
F	HI 80/1100	1106	43,5	756,96	1
F	HI 80/1200	1206	47,5	819,19	1
F	HI 80/1300	1306	51,4	881,42	1
F	HI 80/1400	1406	55,4	943,65	1
F	HI 80/1500	1506	59,3	1.005,88	1
F	HI 80/1600	1606	63,2	1.068,11	1
F	HI 80/1700	1706	67,2	1.130,34	1
F	HI 80/1800	1806	71,1	1.192,57	1
F	HI 80/1900	1906	75	1.254,80	1
F	HI 80/2000	2006	79	1.317,03	1

Suitable for: KTT... and KTTS... type brackets

The load rating shown is valid only for proper anchorage to the building structure. Please consult structural engineering for details and local regulations.

Load Chart: Deflection of Overhead Hanger (onesided load)

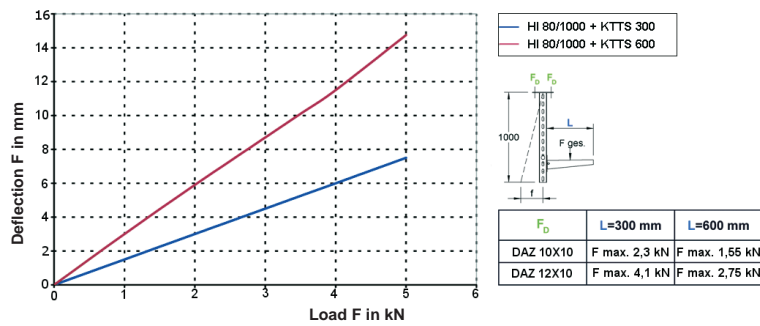

There is no noticeable deflection of the hanger for balanced (twosided) loading.

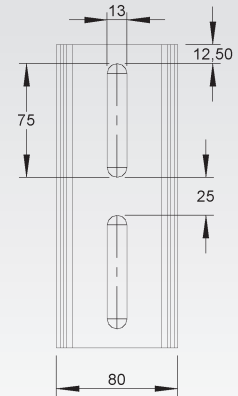
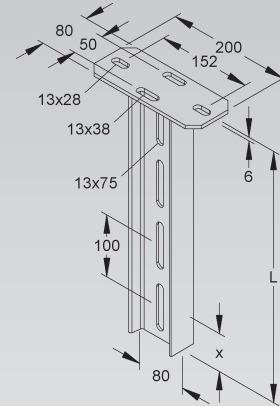

Protective End Cap

model no.	color	Weight per 100 pcs kg	Pack/Box Qty	
K03	SKI 80	yellow	1,54	20

protective end cap

Suitable for: profile I 80/... as well as overhead hanger HI 80/...

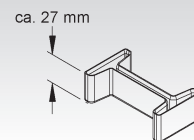

Profile I 80

according to DIN 1025 standard

	model no.	length A		Weight per 100 pcs/m kg	Pack/Box Qty
		mm	Inch		
F	I 80/1000 FL	1000	39,4	622,30	1
F	I 80/1500 FL	1500	59,1	933,45	1
F	I 80/2000 FL	2000	78,7	1.244,61	1
F	I 80/3000 FL	3000	118,1	622,30	3 m
F	I 80/6000 FL	6000	236,2	622,30	6 m

for building customized overhead hangers, floorstands or support frames

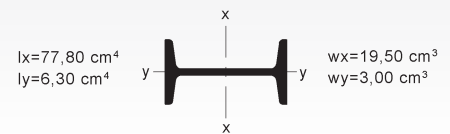
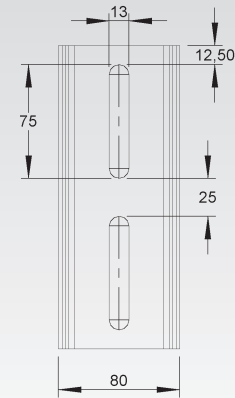
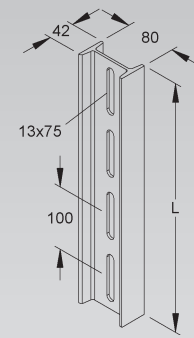

Straight Splice Plate

model no.	Weight per 100 pair kg	Pack/Box Qty
F VBI 80	76	5 sets

2 pieces required per joint

Suitable for: profile I 80/... and overhead hanger HI 80/...

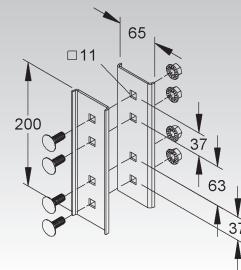

Tee Connector

model no.	Weight per 100 pair kg	Pack/Box Qty
F VBIQ 80/140	90	5 sets

2 pieces required per joint

Suitable for: profile I 80/... and overhead hanger HI 80/...

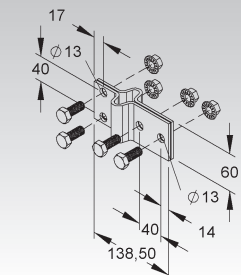

SUPPORT SYSTEM

Two Hole Corner Angle for I 80

equal-sided

model no.	Weight per 100 pc. kg	Pack/Box Qty
F WWI 80	28,67	50

for wall-mounting of I 80/... profiles

Suitable for: profile I 80/..., overhead hangers HI 80/... and vertical cable ladders of type STIC.... and STIW...

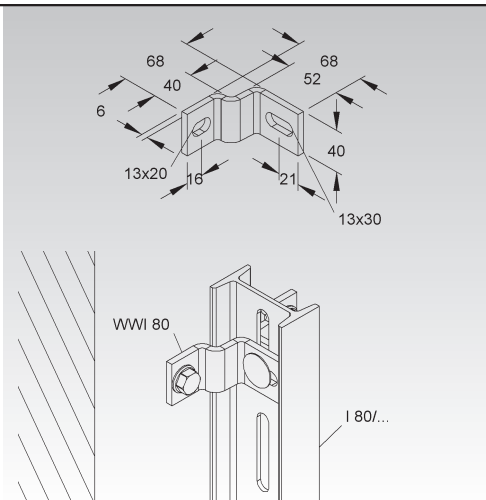

Head Plate

model no.	Total length L mm Inch	thickness of the head plate t mm Inch	Weight per 100 pcs kg	Pack/Box Qty
F KI 80	151 5,9	6 0,2	135,9	1

for mounting on horizontal ceilings

Suitable for: profile I 80/...

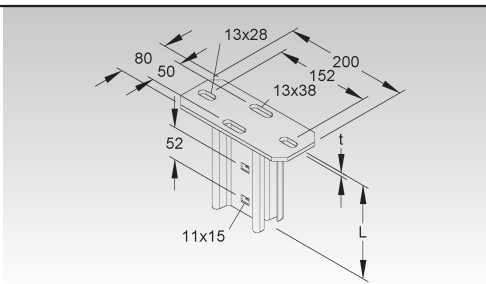

Head Plate Extender Device

model no.	Weight per 100 pc. kg	Pack/Box Qty
F KIA 80	240,91	5

for extending the center distance in between the anchors and to increase the load rating of the overhead hanger HI 80/...

Suitable for: overhead hanger HI 80/... and I 80/...profile with head plate KI 80/...

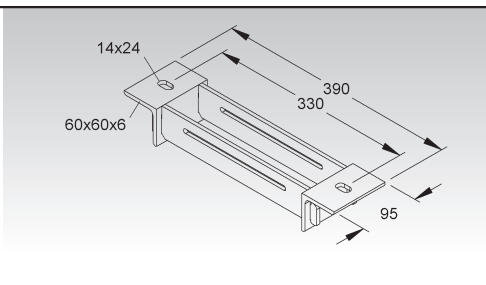

Head Plate

crosswise to profile I 80

model no.	Total length L mm Inch	thickness of the head plate t mm Inch	Weight per 100 pcs kg	Pack/Box Qty
F KIQ 80	151 5,9	6 0,2	151,76	1

for mounting on horizontal ceilings

Suitable for: profile I 80/...

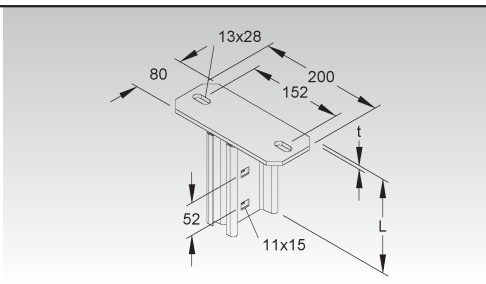

Head Plate

vertical, adjustable from -50° to +50°

model no.	Total length L mm Inch	thickness of the head plate t mm Inch	Weight per 100 pcs kg	Pack/Box Qty
F KIGV 80	261 10,3	6 0,2	213,4	1

for mounting on inclined ceilings

Suitable for: profile I 80/...

Unit is preassembled.

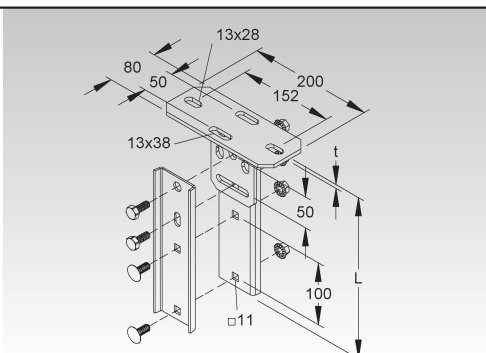

Head Plate

adjustable from -50° to +50°

model no.	Total length L mm Inch	thickness of the head plate t mm Inch	Weight per 100 pc. kg	Pack/Box Qty
F KIGVQ 80	261 10,3	6 0,2	156	1

for mounting on inclined ceilings and support beams

Suitable for: profile I 80/...

Installation mode: crosswise to the support beam

Unit is preassembled.

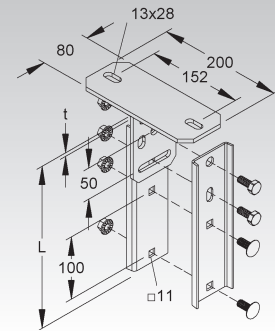

Clamping Head Plate

model no.	slot width mm Inch	Total length L mm Inch	thickness of the head plate t mm Inch	Weight per 100 pcs kg	Pack/Box Qty
F KIDK 80	22 0,9	153 6	8 0,3	310,14	1

for clamping to horizontal support beams (max. width 240 mm)

Suitable for: profile I 80/...

Installation mode: crosswise to the support beam

Hardware not included. Please order beam clamps and bolts separately.

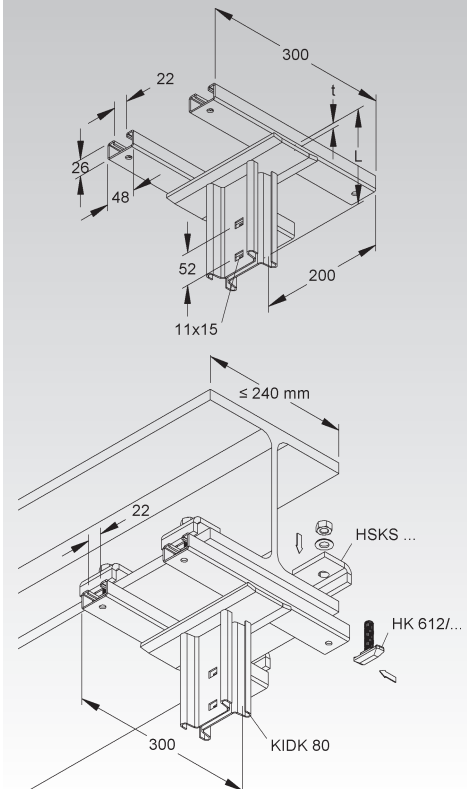

SUPPORT SYSTEM

Clamping Head Plate

model no.	slot width mm Inch	Weight per 100 pcs. kg	Pack/Box Qty
F KIDP 80	22 0,9	150,49	1

for clamping to horizontal support beams (max. width 240 mm)

Suitable for: profile I 80/...

Installation mode: in parallel to the support beam

hardware has to be ordered separately: 2 x HK 610/..., 2 x HSKS...

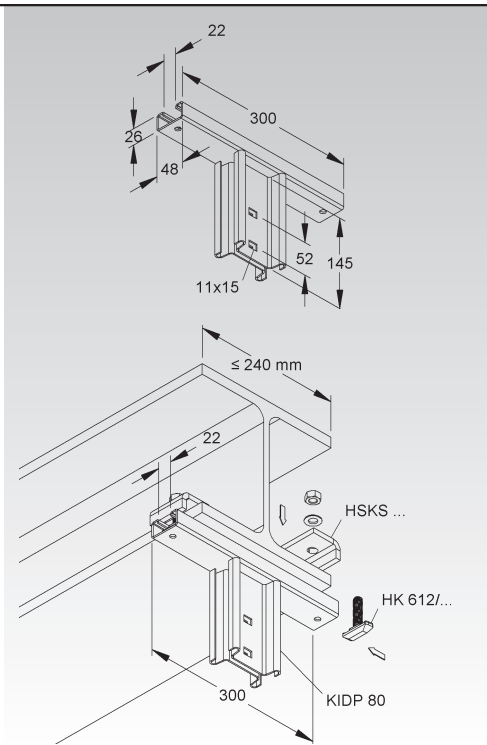

Bracket

medium-duty with preinstalled clamp

model no.	height H mm Inch	length A mm Inch	admissible load F at L/2 kN	Weight per 100 pcs kg	Pack/Box Qty
F KTT 100	55 2,2	110 4,3	2,5	33,9	20
F KTT 150	55 2,2	160 6,3	2,5	37,2	20
F KTT 200	55 2,2	210 8,3	2,5	44,3	20
F KTT 250	75 3	260 10,2	2,5	53,4	20
F KTT 300	75 3	310 12,2	2,5	60,0	20
F KTT 350	75 3	360 14,2	2,5	79,8	20
F KTT 400	95 3,7	410 16,1	2,5	85,0	20
F KTT 450	95 3,7	460 18,1	2,5	100,2	10
F KTT 500	95 3,7	510 20,1	2,5	119,5	10
F KTT 550	95 3,7	560 22	2,5	141,7	10
F KTT 600	95 3,7	610 24	2,5	136,0	10

Suitable for: profile I 80/... as well as overhead hanger HI 80/...

The load rating shown is valid only for proper anchorage to the building structure. Please consult structural engineering for details and local regulations.

Hardware for mounting cable ladders has to be ordered separately.

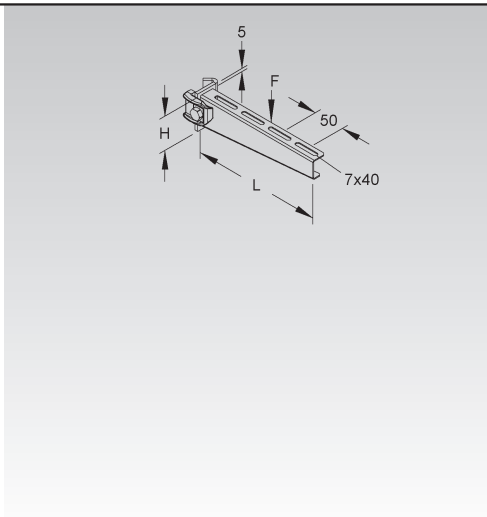

Protective End Cap

model no.	color	Weight per 100 pcs kg	Pack/Box Qty
K10 KA 100-600	yellow	1,4	10

protective end cap for cable tray brackets

Suitable for: KTA..., KTT... and KTU... brackets

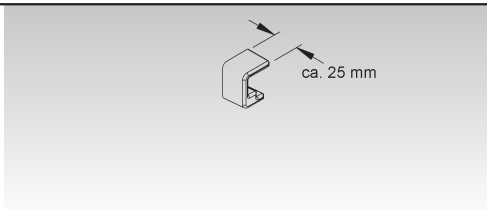

Bracket

heavy-duty with pre-installed clamp

	model no.	height H		length A		admissible load F at L/2 kN	Weight per 100 pcs kg	Pack/Box Qty
		mm Inch	mm Inch	mm Inch	mm Inch			
F	KTTS 200	110 4,3	230 9,1	5	80,8	1		
F	KTTS 300	110 4,3	330 13	5	108,7	1		
F	KTTS 400	110 4,3	430 16,9	5	132,8	1		
F	KTTS 500	150 5,9	530 20,9	5	170,3	1		

Suitable for: profile I 80/... and overhead hanger HI 80/...

The load rating shown is valid only for proper anchorage to the building structure. Please consult structural engineering for details and local regulations.

Hardware for mounting cable ladders has to be ordered separately.

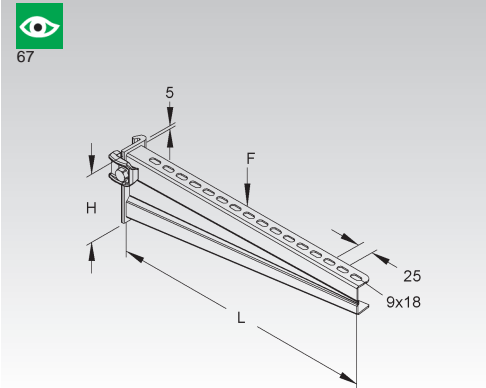

Bracket

heavy-duty with two pre-installed clamp

	model no.	height H		length A		admissible load F at L/2 kN	Weight per 100 pcs kg	Pack/Box Qty
		mm Inch	mm Inch	mm Inch	mm Inch			
F	KTTS 600	150 5,9	630 24,8	5	212,3	1		
F	KTTS 700	150 5,9	730 28,7	5	286,7	1		
F	KTTS 800	190 7,5	830 32,7	5	339,3	1		
F	KTTS 900	190 7,5	930 36,6	5	383,7	1		
F	KTTS 1000	190 7,5	1030 40,6	5	430,9	1		

Suitable for: profile I 80/... and overhead hanger HI 80/...

The load rating shown is valid only for proper anchorage to the building structure. Please consult structural engineering for details and local regulations.

Hardware for mounting cable ladders has to be ordered separately.

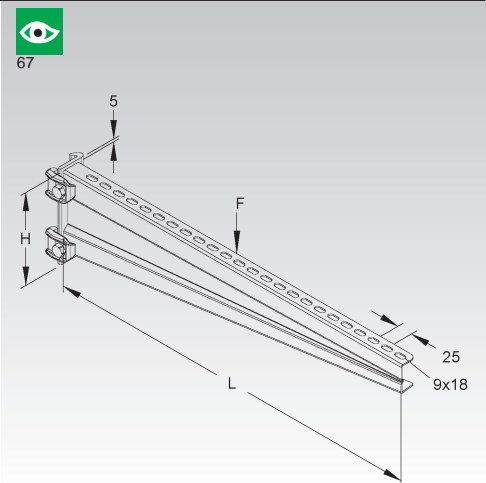

Channels, Rails, Clamps and Accessories

SYSTEM	2970 Framing Channel	2970/...	Page 120
	Sloped Sliding Nut	GSM...	Page 120
	Sloped Sliding Nut	GSF...	Page 120
	2986 Framing Channel	2986/...	Page 120
	Protective End Cap	SKC 86	Page 121
	2991 Framing Channel	2991/...	Page 121
★	Protective End Cap	SKC 2991	Page 121
	2996Z Framing Channel	2996Z/...	Page 122
	Protective End Cap	SKC 88/96	Page 122
	Inside Strut Joiner	SSV 4141 F	Page 122
	Channel Nut	GMZ...	Page 122/123
	Gripping Channel Nut	GMZF...	Page 123
	Hook Head Bolt	HK...	Page 124/125
	Beam Clamp	HSK..., HSKS...	Page 125
★	I-Beam Clamping Assembly	SPKM 25 F/SPKGM 25 F	Page 126
★	Heavy Duty I-Beam Clamping Assembly	SPPM 30 F/SPPGM 30 F	Page 127
	Two Hole Corner Angle	WWU 150...	Page 127/128
	Three Hole Corner Angle	WWA 100...	Page 128
	Four Hole Corner Gusset Plate	KNW 50/50	Page 128
	Five Hole Tee Gusset Plate	KNT 50/50	Page 128
	Shelf Bracket	TRV 40...	Page 129
	Adjustable Corner Bracket	AWG 110/140...	Page 129
	Heavy Duty Square Washer / Anchor Plate	VP 50.50	Page 129
	Column Support	TZK 86-96 S	Page 129
★	Hammerset Flange Clamp	TKM...	Page 130
★	Flange Clamp	PKS...	Page 130
	C-Clamp with Locknut	FC...	Page 130
	Hexagonal Bolt	SK..., SKM...	Page 131
	Mushroom Head Bolt	FLM..., FLDM...	Page 131/132
★	Threaded Rod	M 6/...	Page 132
	Threaded Rod	M 8/..., M 10/..., M 12/...	Page 132/133
	Large Diameter Washer	UGM...	Page 133
	Hexagonal Nut	SMU...	Page 133
	Hexagonal Rod Coupling	VBSM...	Page 133
	Serrated Washer	ZS...	Page 133
	Nail Anchor	DAM...	Page 134
	Bolt Anchor	DAZ...	Page 134
	Edge Protection Strip	RKBA...	Page 134
	Edge Protection Ring	KSR...	Page 134/135
	Punch and Die Set	BL...	Page 135
	Yoke-Clamp	BA..., BAK..., B...	Page 136
	Yoke-Clamp	BK...	Page 137
	Yoke-Clamp	BU...	Page 137
	Yoke-Clamp	BUK...	Page 137
	Yoke-Clamp	BWK...	Page 138
	Counter Pressure Cradle for all Yoke-Clamps	GWU...	Page 138



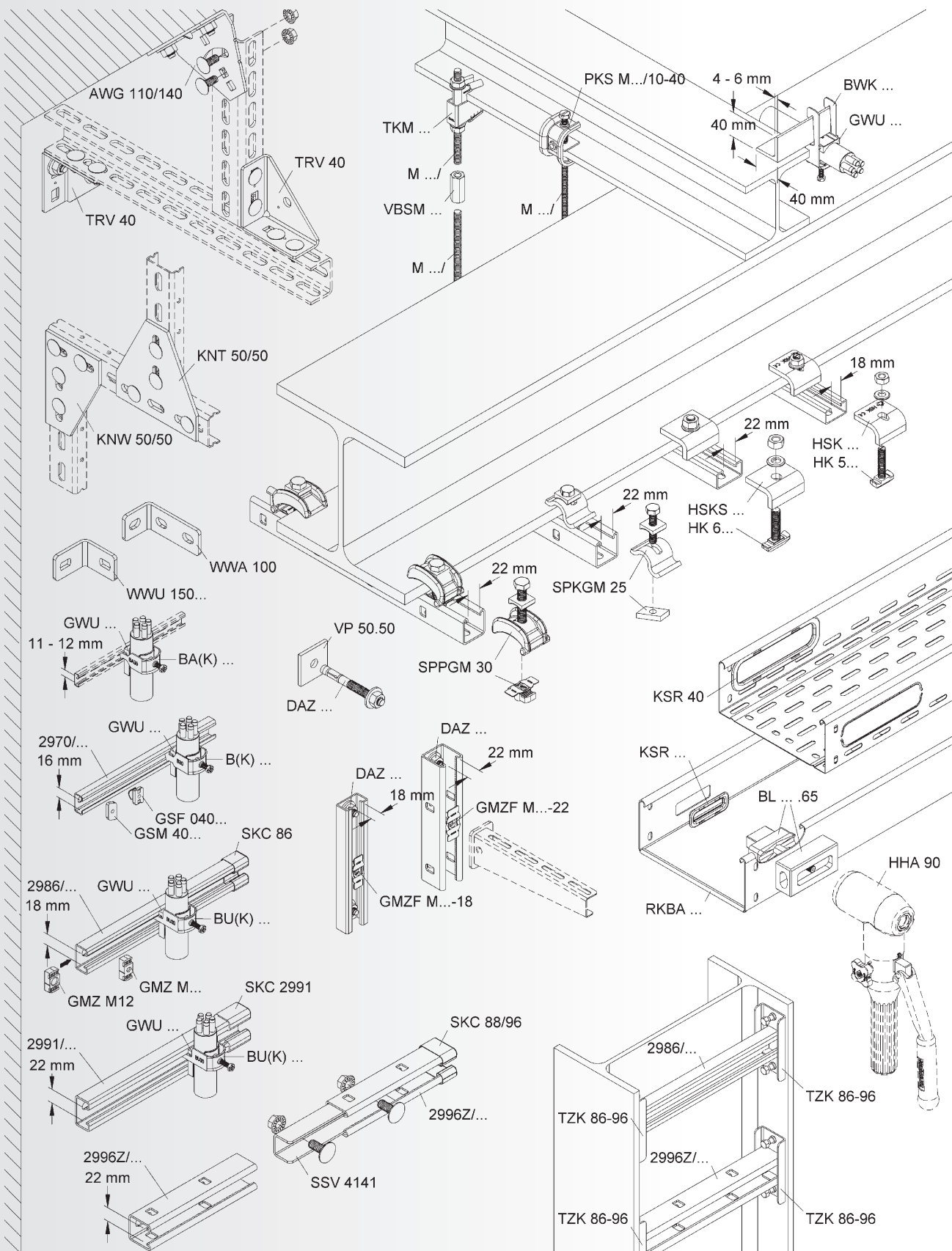

SUPPORT SYSTEM

2970 Framing Channel

slot width 16 mm, perforated

	model no.	length A		perforation	distance between drill holes		Weight per 100 m kg	Pack/Box Qty
		mm	Inch		mm	mm Inch		
G	2970/2 GL	2000	78,7	9x15	25 1	69,9	10 x 2 m	
S	2970/2 SL	2000	78,7	9x15	25 1	69,9	10 x 2 m	

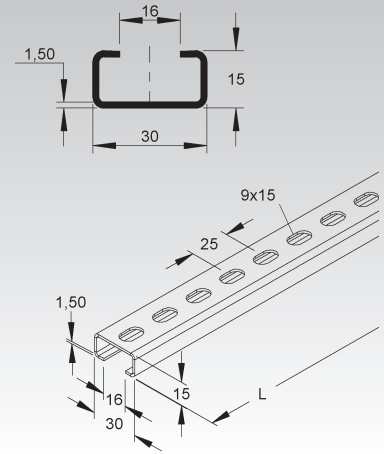

Sloped Sliding Nut

	model no.	thread M	height H		Weight per 100 pc. kg	Pack/Box Qty
			mm	Inch		
G	GSM 0406	6	4	0,2	1,04	50
G	GSM 0408	8	4	0,2	0,99	50

Suitable for: 2970 and 2980 channel (16 mm slotwidth)

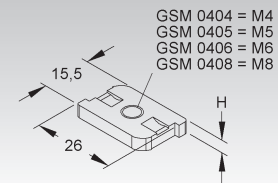

Sloped Sliding Nut

with clamping spring (phosphated)

	model no.	thread M	height H		Weight per 100 pcs kg	Pack/Box Qty
			mm	Inch		
G	GSF 0406	6	4	0,2	1,04	25
G	GSF 0408	8	4	0,2	1,02	25

Suitable for: 2970 framing channel (16 mm slotwidth)
Insertable at any position of the framing channel.

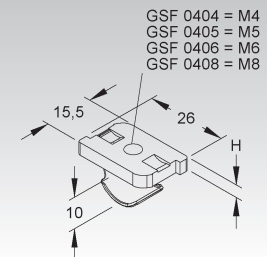

2986 Framing Channel

C-rail, slot width 18 mm, perforated, according to DIN EN 60715 standard

	model no.	length A		perforation	distance between drill holes		Weight per 100 m/kg	Pack/Box Qty
		mm	Inch		mm	mm Inch		
S	2986/200 SL	200	7,9	11,5x30	50 2	29,81	1	
S	2986/300 SL	300	11,8	11,5x30	50 2	44,72	1	
S	2986/400 SL	400	15,7	11,5x30	50 2	59,63	1	
S	2986/500 SL	500	19,7	11,5x30	50 2	74,53	1	
S	2986/600 SL	600	23,6	11,5x30	50 2	89,44	1	
S	2986/700 SL	700	27,6	11,5x30	50 2	104,35	1	
S	2986/3 SL	3000	118,1	11,5x30	50 2	149,10	5 x 3 m	
F	2986/3 FL	3000	118,1	11,5x30	50 2	163,97	5 x 3 m	
E3	2986/3 E3L	3000	118,1	11,5x30	50 2	150,02	5 x 3 m	

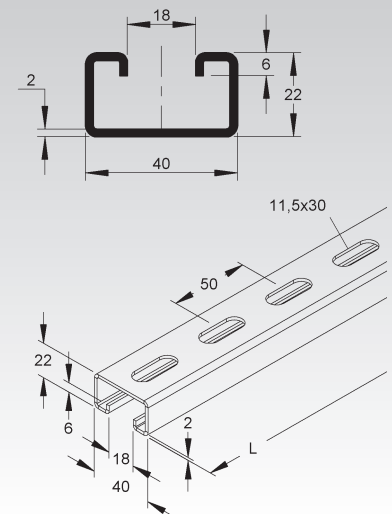

Protective End Cap

model no.	color	Weight per 100 pcs kg	Pack/Box Qty
K03 SKC 86	yellow	0,79	20

protective end cap

Suitable for: 2986 framing channel

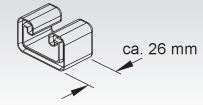

2991 Framing Channel

slot width 22 mm, perforated

	model no.	length A		perforation	distance between drill holes		Weight per 100 m/kg	Pack/Box Qty
		mm	Inch		mm	mm		
F	2991/200 FL	200	7,9	11,5x30	50	2	48,06	1
F	2991/300 FL	300	11,8	11,5x30	50	2	72,10	1
F	2991/400 FL	400	15,7	11,5x30	50	2	96,10	1
F	2991/500 FL	500	19,7	11,5x30	50	2	120,10	1
F	2991/600 FL	600	23,6	11,5x30	50	2	144,17	1
F	2991/700 FL	700	27,6	11,5x30	50	2	168,19	1
F	2991/3 FL	3000	118,1	11,5x30	50	2	240,27	5 x 3 m

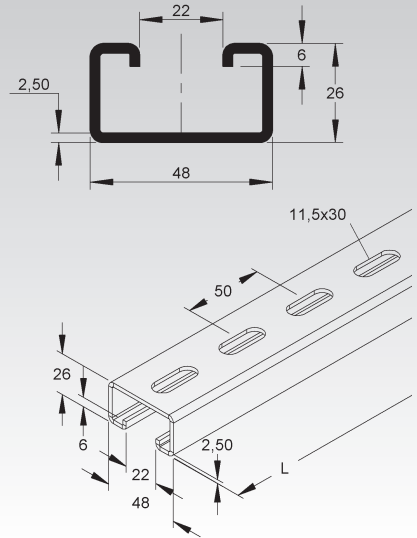

Protective End Cap

model no.	color	Weight per 100 kg	Pack/Box Qty
K10 SKC 2991	yellow	2,33	10

protective end cap

Suitable for: 2991 framing channel

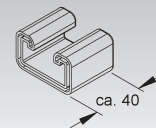

SUPPORT SYSTEM

2996Z Toothed Framing Channel

slot width 22 mm, perforated

	model no.	length A		perforation mm	distance between drill holes mm Inch		dimension siderail holes mm	distance between siderail holes mm Inch		Weight per 100 m kg	Pack/ Box Qty
		mm	Inch		mm	Inch		mm	Inch		
F	2996Z/3 FL	3000	118,1	13x30	50 2	11x15	100 3,9	265,10	3 m		
F	2996Z/6 FL	6000	236,2	13x30	50 2	11x15	100 3,9	265,20	6 m		
E3	2996Z/3 E3L	3000	118,1	13x30	50 2	11x15	100 3,9	242,25	3 m		
E3	2996Z/6 E3L	6000	236,2	13x30	50 2	11x15	100 3,9	242,25	6 m		

The combination of the toothed channel with the new GMZ channel nuts guarantees higher load ratings.

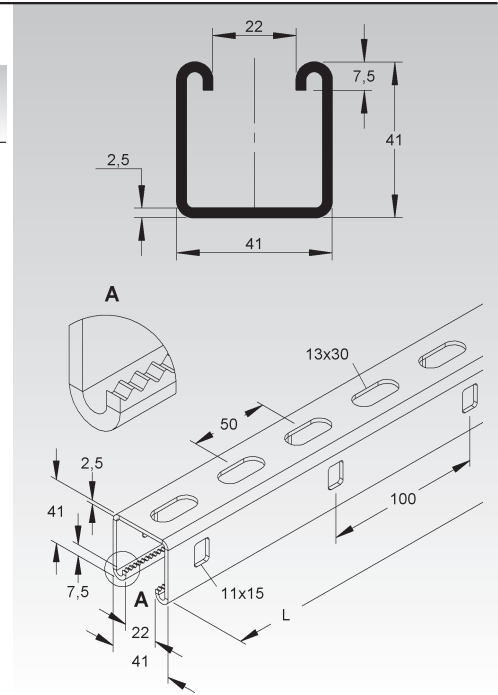

Protective End Cap

model no.	color	Weight per 100 pcs kg	Pack/ Box Qty
K03 SKC 88/96	yellow	1,32	20

protective end cap

Suitable for: 2988..., 2996... and 2996Z... framing channel

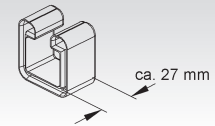

Inside Strut Joiner

for 2996 channel

model no.	Weight per 100 pcs kg	Pack/ Box Qty
F SSV 4141 F	55,28	1

Suitable for: 2996... framing channel

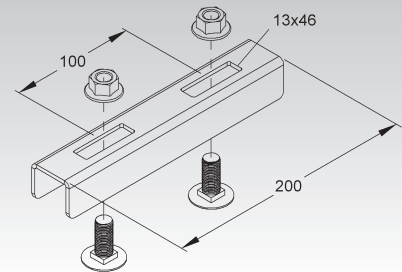

Channel Nut

model no.	thread M	strength category	Weight per 100 pcs kg	Pack/ Box Qty
F GMZ M6 F	6	8	3,5	100
F GMZ M8 F	8	8	3,3	100
F GMZ M10 F	10	8	3,2	100

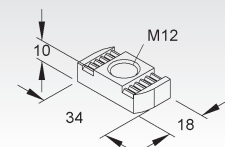
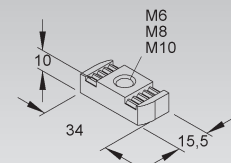

Channel Nut

model no.	thread M	strength category	Weight per 100 pcs kg	Pack/Box Qty
F GMZ M12 F	12	8	3,5	100

Do not use GMZ M12 F with 2986-1.75 framing channel.

The GMZ M12 F channel nuts can be inserted only from the end of framing channel with 18 mm slotwidth.

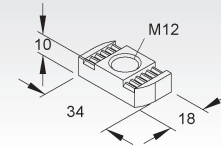
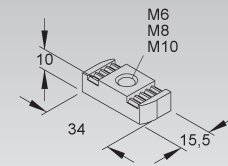

Gripping Channel Nut

model no.	thread M	strength category	Weight per 100 pcs kg	Pack/Box Qty
F GMZF M6-18 F	6	8	3,66	100
F GMZF M8-18 F	8	8	3,52	100
F GMZF M10-18 F	10	8	3,36	100
F GMZF M12-18 F	12	8	3,71	100
E5 GMZF M6-18 E5	6	1.4571	3,72	100
E5 GMZF M8-18 E5	8	1.4571	3,58	100
E5 GMZF M10-18 E5	10	1.4571	3,41	100
E5 GMZF M12-18 E5	12	1.4571	3,77	100

Do not use GMZ M12-18 F with 2986-1.75 framing channel.

Suitable for: 2986... and 2988... framing channel (18 mm slotwidth)

The GMZ M12-18... channel nuts can be inserted only from the end of a framing channel with 18 mm slotwidth.

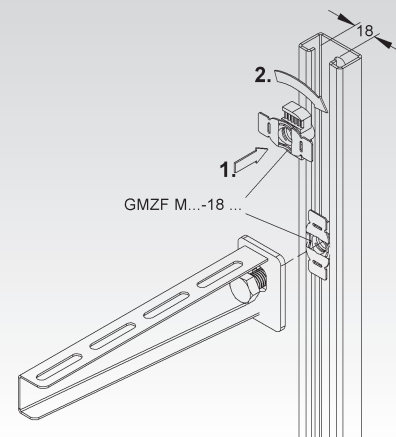
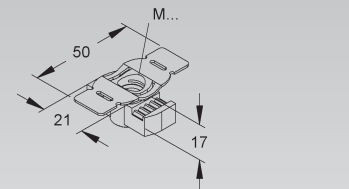

Gripping Channel Nut

model no.	thread M	strength category	Weight per 100 pcs kg	Pack/Box Qty
F GMZF M6-22 F	6	8	3,70	100
F GMZF M8-22 F	8	8	3,57	100
F GMZF M10-22 F	10	8	3,40	100
F GMZF M12-22 F	12	8	3,76	100
E5 GMZF M6-22 E5	6	1.4571	3,76	100
E5 GMZF M8-22 E5	8	1.4571	3,62	100
E5 GMZF M10-22 E5	10	1.4571	3,45	100
E5 GMZF M12-22 E5	12	1.4571	3,81	100

Suitable for: 2991..., 2996... and 2996Z... framing channel (22 mm slotwidth)

Insertable at any position of the framing channel.

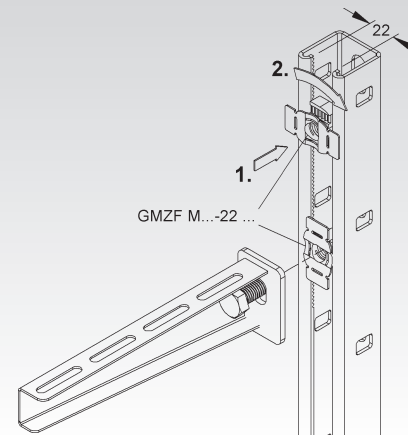
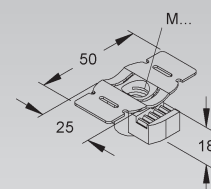

SUPPORT SYSTEM

Hook Head Bolt, size M10

nut and washer included

	model no.	length A		strength category	Weight per 100 pcs/kg	Pack/Box Qty
		mm	Inch			
V	HK 510/30	30	1,2	4.6	4,3	100
V	HK 510/50	50	2	4.6	5,4	50
F	HK 510/30 F	30	1,2	4.6	4,3	100
F	HK 510/50 F	50	2	4.6	5,4	50
F	HK 510/80 F	80	3,1	4.6	6,8	50

Suitable for: 2986... framing channel (18 mm slotwidth)

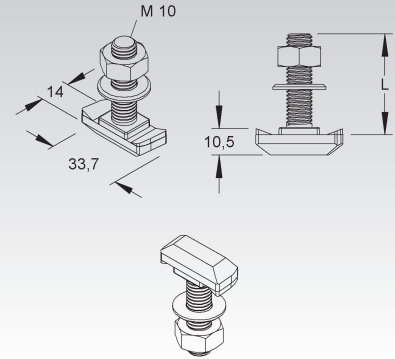

Hook Head Bolt, size M10

nut and washer included

	model no.	length A		strength category	Weight per 100 pcs/kg	Pack/Box Qty
		mm	Inch			
V	HK 610/30	30	1,2	4.6	5,3	100
V	HK 610/40	40	1,6	4.6	6,0	100
V	HK 610/50	50	2	4.6	6,6	50
V	HK 610/80	80	3,1	4.6	7,7	50
F	HK 610/30 F	30	1,2	4.6	5,6	100
F	HK 610/50 F	50	2	4.6	6,5	50
F	HK 610/80 F	80	3,1	4.6	7,9	50

Suitable for: 2991... framing channel (22 mm slotwidth)

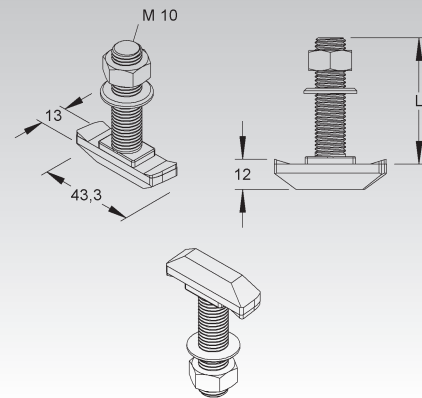

Hook Head Bolt, size M12

nut and washer included

	model no.	length A		strength category	Weight per 100 pcs/kg	Pack/Box Qty
		mm	Inch			
F	HK 512/30 F	30	1,2	4.6	5,1	100
F	HK 512/50 F	50	2	4.6	6,5	50
F	HK 512/80 F	80	3,1	4.6	8,6	50

Suitable for: 2986... and 2988... framing channel (18 mm slotwidth)

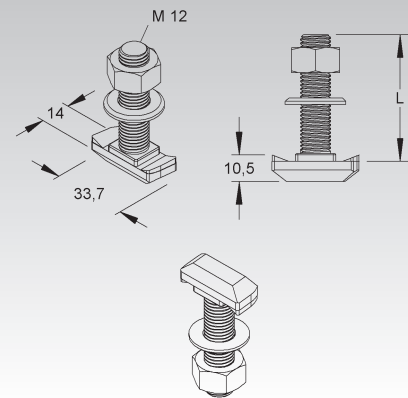

Hook Head Bolt, size M12

nut and washer included

	model no.	length A		strength category	Weight per 100 pcs./pc./kg	Pack/Box Qty
		mm	Inch			
V	HK 612/30	30	1,2	4.6	5,4	100
V	HK 612/50	50	2	4.6	7,5	50
V	HK 612/80	80	3,1	4.6	9,4	50
F	HK 612/30 F	30	1,2	4.6	5,6	100
F	HK 612/50 F	50	2	4.6	7,0	50
F	HK 612/80 F	80	3,1	4.6	9,3	50

Suitable for: 2991... framing channel (22 mm slotwidth)



52

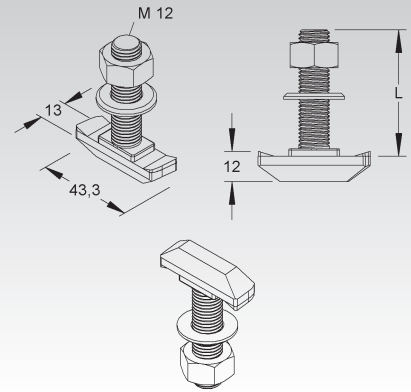

Beam Clamp

	model no.	height H		thickness t	flange thickness t	Weight per 100 pcs/kg	Pack/Box Qty
		mm	Inch				
F	HSK 10	10	0,4	7	5 - 9	15,44	50
F	HSK 15	15	0,6	7	10 - 14	16,92	50
F	HSK 20	20	0,8	7	15 - 19	18,43	50
F	HSK 25	25	1	7	20 - 24	19,95	50
F	HSK 30	30	1,2	7	25 - 29	21,46	50
F	HSK 35	35	1,4	7	30 - 34	22,97	50
F	HSK 40	40	1,6	7	35 - 39	24,48	50
E3	HSK 10 E3	10	0,4	6	5 - 9	11,93	10
E3	HSK 15 E3	15	0,6	6	10 - 14	13,09	10
E3	HSK 20 E3	20	0,8	6	15 - 19	14,28	10
E3	HSK 25 E3	25	1	6	20 - 24	15,46	10
E3	HSK 30 E3	30	1,2	6	25 - 29	16,65	10
E3	HSK 35 E3	35	1,4	6	30 - 34	17,72	10
E3	HSK 40 E3	40	1,6	6	35 - 39	19,02	10



52

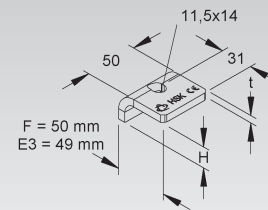

Beam Clamp

heavy-duty version

	model no.	height H		flange thickness t	Weight per 100 pcs/kg	Pack/Box Qty
		mm	Inch			
F	HSKS 10	10	0,4	5 - 9	21	25
F	HSKS 15	15	0,6	10 - 14	25	25
F	HSKS 20	20	0,8	15 - 19	27	25
F	HSKS 25	25	1	20 - 24	33	25
F	HSKS 30	30	1,2	25 - 29	41	25
F	HSKS 35	35	1,4	30 - 34	49	25
F	HSKS 40	40	1,6	35 - 39	60	25



52

67

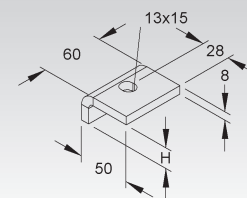

I-Beam Clamping Assembly

model no.	flange thickness t mm	Weight per 100 kg	Pack/ Box Qty
-----------	-----------------------------	-------------------------	------------------

★ **F** **SPKM 25 F** 0 - 25 28 10

for attaching headplates or hangers directly to I-beams

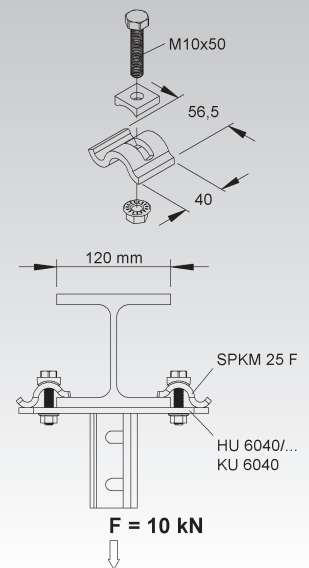

I-Beam Clamping Assembly

with sliding nut

model no.	flange thickness t mm	Weight per 100 kg	Pack/ Box Qty
-----------	-----------------------------	-------------------------	------------------

★ **F** **SPKGM 25 F** 0 - 25 42 10

for attaching C-rails-mounted headplates or hangers to I-beams

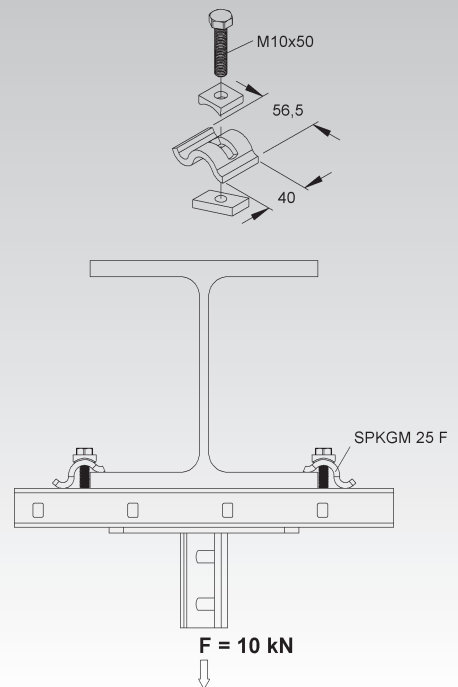

Heavy Duty I-Beam Clamping Assembly

model no.	flange thickness t mm	Weight per 100 kg	Pack/Box Qty
F SPPM 30 F	0 - 25	80	10

for attaching headplates or hangers directly to I-beams

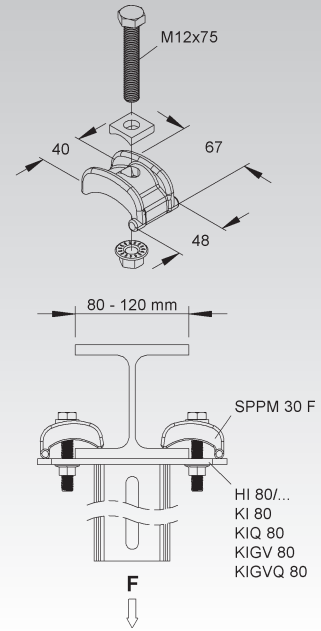
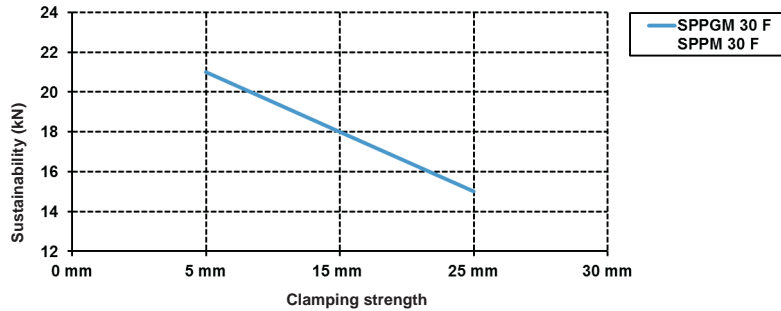

Heavy Duty I-Beam Clamping Assembly

with sliding nut

model no.	flange thickness t mm	Weight per 100 kg	Pack/Box Qty
F SPPGM 30 F	0 - 25	82	10

for attaching C-rail-mounted headplates or hangers to I-beams

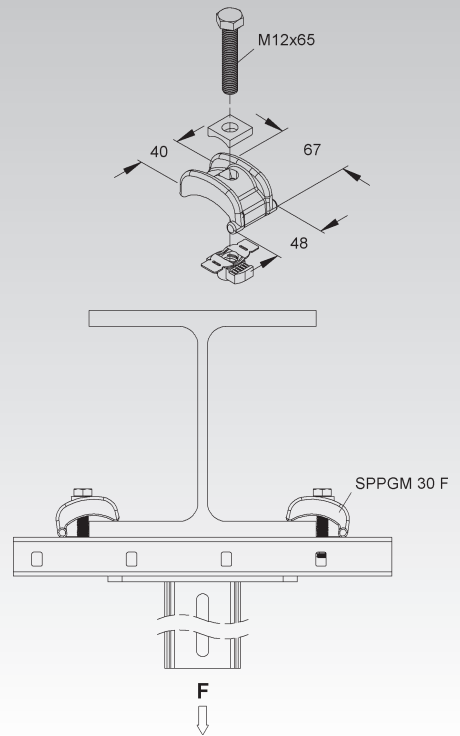
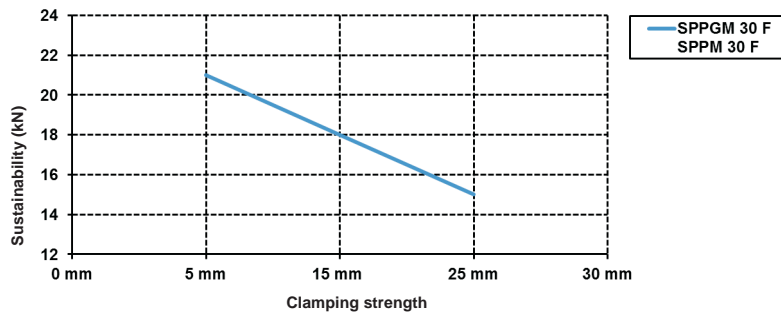

Two Hole Corner Angle

model no.	thick-ness t mm	Weight per 100 pcs kg	Pack/Box Qty
F WWU 150/8	5	19,11	50

for floor-, ceiling- or wall-mount

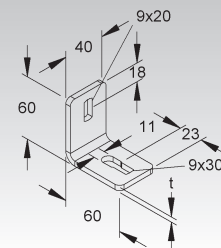

SUPPORT SYSTEM

Two Hole Corner Angle

model no.	Weight per 100 pcs kg	Pack/Box Qty
F WWU 150	21,03	50

for floor-, ceiling- or wall-mount

Suitable for: U-profile U 50/..., U 5050/... and U 6040/...

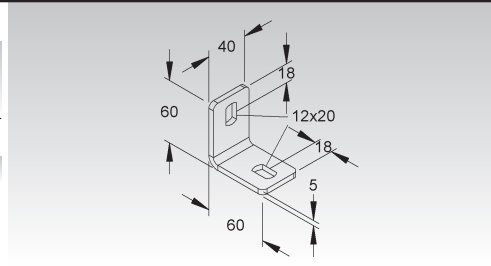

Two Hole Corner Angle

model no.	thickness t mm	Weight per 100 pcs kg	Pack/Box Qty
E3 WWU 150/8 E3	4	14,87	50

for floor-, ceiling- or wall-mount

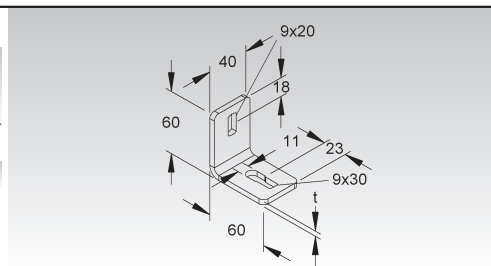

Three Hole Corner Angle

model no.	thickness t mm	Weight per 100 pcs kg	Pack/Box Qty
F WWA 100	5	24,98	50
E3 WWA 100 E3	4	19,75	50

for floor-, ceiling- or wall-mount

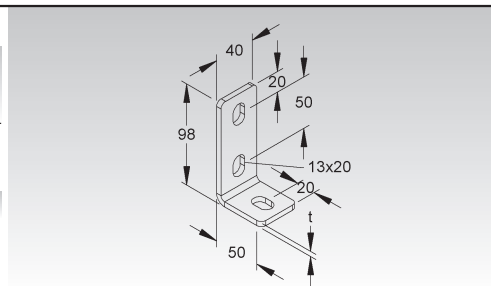

Four Hole Corner Gusset Plate

model no.	thickness t mm	Weight per 100 kg	Pack/Box Qty
F KNW 50/50	5	43	1

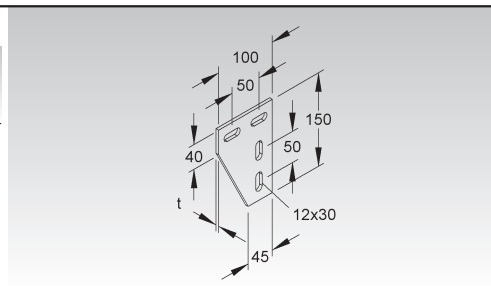

Five Hole Tee Gusset Plate

model no.	thickness t mm	Weight per 100 kg	Pack/Box Qty
F KNT 50/50	5	59	1

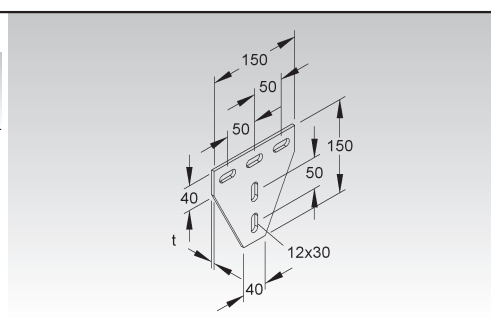

Shelf Bracket

model no.	Weight per 100 pcs kg	Pack/Box Qty
F TRV 40	41,1	10
E3 TRV 40 E3	40,5	10

for floor-, ceiling- or wall-mount

Suitable for: profile U 5050/..., U 6040/... and framing channels

Hardware is not included.

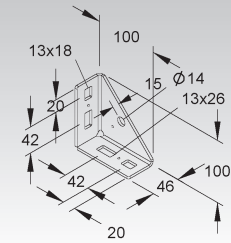

Adjustable Corner Bracket

adjustable from -30° to +30°

model no.	Weight per 100 pcs kg	Pack/Box Qty
F AWG 110/140	48,00	10
E3 AWG 110/140 E3	54,61	10

for mounting on inclined ceilings

Suitable for: U-profiles and framing channels

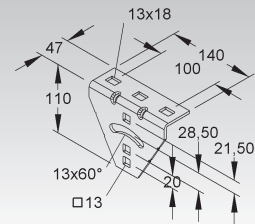

Heavy Duty Square Washer/Anchor Plate

model no.	height H mm Inch	width B mm Inch	Weight per 100 pcs kg	Pack/Box Qty
F VP 50.50	50 2	50 2	10,34	20

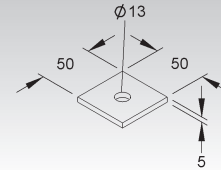

Column Support for 2986 and 2996 Channel

model no.	width B mm Inch	length A mm Inch	thickness t mm	admissible load F at flange distance of I-beam kN	Weight per 100 kg	Pack/Box Qty
G TZK 86-96 S	45,5 1,8	100 3,9	2	0,5	24,74	10

for clamping channels in between I-beam flanges

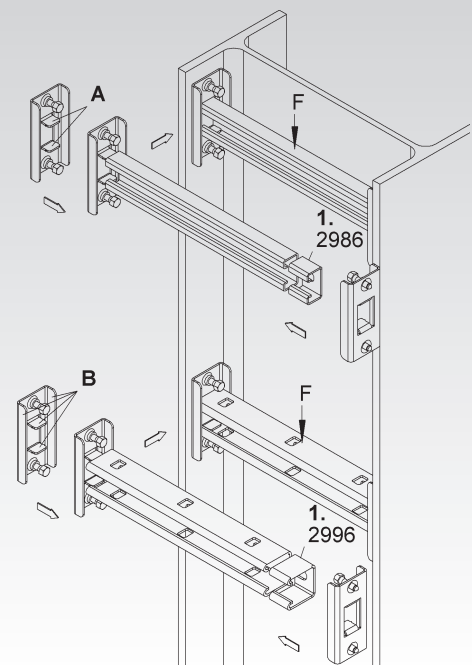
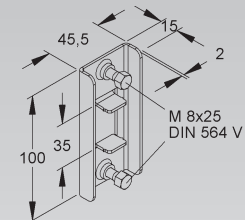

SUPPORT SYSTEM

Hammerset Flange Clamp

model no.	width B		width B1		Threading rod-Ø	thickness of flange (t)	vertical nominal load F kN	Weight per 100 kg	Pack/Box Qty
	mm	Inch	mm	Inch					
★ S TKM 1	17,5	0,7	8,5	0,3	≤ M8	8-20	2,0	16,5	25
★ S TKM 2	19,5	0,8	10,5	0,4	≤ M10	8-20	3,6	16,7	25
★ S TKM 3	21,5	0,8	12,5	0,5	≤ M12	8-20	5,0	17,4	25

for attaching threaded rod to flanges of 8 to 20 mm thickness



51

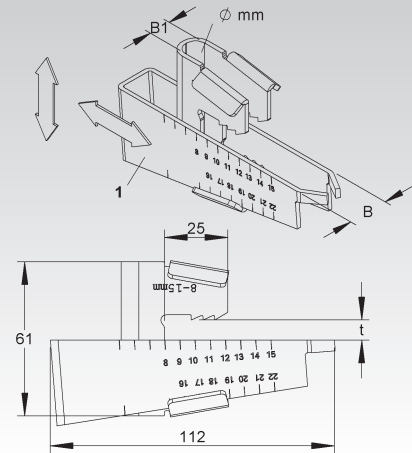

Flange Clamp

model no.	thread M	thickness of flange (t)	vertical nominal load F kN	Weight per 100 kg	Pack/Box Qty
★ F PKS M6/10-40 F	6	≤ 35	1,5	20,27	25
★ F PKS M8/10-40 F	8	≤ 35	1,5	21,20	25
★ E3 PKS M8/10-40 E3	8	≤ 35	1,5	19,40	25



51

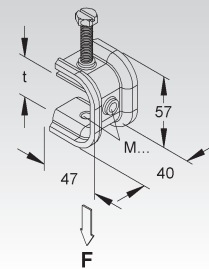

C-Clamp with Locknut

model no.	T	Ø	distance between drilling holes A	B	C	admissible load F kN	Weight per 100 kg	Pack/Box Qty
F1 FC-7	1 - 19	7	50	42	45	2,35	15,6	25
F1 FC-9	1 - 19	9	50	42	45	2,35	14,8	25
F1 FC-11	1 - 19	11	50	42	45	2,35	14,8	25
F1 FC-13	1 - 23	13	59	49	54	3	14,4	25
F1 FC-6T	1 - 19	M6	50	42	45	2,35	15,6	25
F1 FC-8T	1 - 19	M8	50	42	45	2,35	15,2	25
F1 FC-10T	1 - 19	M10	50	42	45	2,35	15,2	25
F1 FC-12T	1 - 23	M12	59	49	54	3	22,8	25

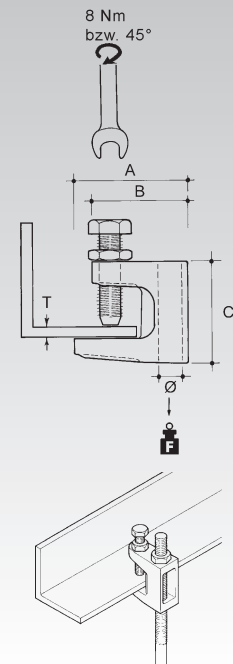

Hexagonal Bolt

model no.	length A	strength category	wrench size	Weight per 100 pcs/ kg	Pack/ Box Qty
	mm Inch				
V SK 8X16 V	16 0,6	8.8	13	1,11	100
V SK 10X25 V	25 1	8.8	17	2,37	100
F SK 8X25 F	25 1	8.8	13	1,39	100
F SK 10X25 F	25 1	8.8	17	2,55	100
E3 SK 8X30 E3	30 1,2	1.4301	13	1,56	100
E3 SK 10X30 E3	30 1,2	1.4301	17	2,62	100



Please maintain proper tightening torque of bolts/nuts especially for all vertical clamping connections.
SK 8..., tightening torque 24 Nm, 13 mm metric wrench
SK10..., tightening torque 48 Nm, 17 mm metric wrench

Hexagonal Bolt

serrated flange nut included

model no.	thread M	length A	strength category	Weight per 100 pcs./pc./ kg	Pack/ Box Qty
		mm Inch			
V SKM 8X16 V	8	16 0,6	8.8	1,72	50
V SKM 10X25 V	10	25 1	8.8	3,60	50
V SKM 10X40 V	10	40 1,6	8.8	4,50	50
V SKM 10X50 V	10	50 2	8.8	5,00	50
V SKM 10X70 V	10	70 2,8	8.8	5,50	50
V SKM 12X50 V	12	50 2	10.9	7,00	20
V SKM 12X70 V	12	70 2,8	10.9	8,44	20
F SKM 10X80 F	10	80 3,1	8.8	6,00	50
F SKM 10X90 F	10	90 3,5	8.8	6,50	50
F SKM 12X50 F	12	50 2	10.9	8,27	20
F SKM 12X70 F	12	70 2,8	10.9	9,85	20
E3 SKM 8X16 E3	8	16 0,6	1.4301	1,72	50
E3 SKM 8X40 E3	8	40 1,6	1.4301	2,00	20
E3 SKM 10X25 E3	10	25 1	1.4301	3,89	50
E3 SKM 10X40 E3	10	40 1,6	1.4301	4,50	50
E3 SKM 10X70 E3	10	70 2,8	1.4301	5,50	50
E3 SKM 10X90 E3	10	90 3,5	1.4301	6,50	50



Please maintain proper tightening torque of bolts/nuts especially for all vertical clamping connections.
SKM 8..., tightening torque 24 Nm, 13 mm metric wrench
SKM 10..., tightening torque 48 Nm, 17 mm metric wrench
SKM 12..., tightening torque 123 Nm, 19 mm metric wrench

Mushroom Head Bolt

serrated flange nut included

model no.	thread M	length A	strength category	Weight per 100 pcs kg	Pack/ Box Qty
		mm Inch			
V FLM 6X12	6	12 0,5	-	0,92	100
F FLM 6X12 F	6	12 0,5	-	1,06	50
F FLM 6X16 F	6	16 0,6	-	0,90	50
F FLM 8X13 F	8	13 0,5	8.8	2,00	100
F FLM 8X16 F	8	16 0,6	8.8	2,09	50
F FLM 8X25 F	8	25 1	8.8	2,80	50
F FLM 10X25 F	10	25 1	8.8	4,00	50
F FLM 12X30 F	12	30 1,2	8.8	8,00	50
E3 FLM 6X12 E3	6	12 0,5	—	0,93	50
E3 FLM 8X16 E3	8	16 0,6	1.4301	2,01	50
E3 FLM 10X25 E3	10	25 1	1.4301	3,99	50



SUPPORT SYSTEM

Mushroom Head Bolt

serrated flange nut included

	model no.	thread M	length A		Weight per 100 pcs kg	Pack/ Box Qty
			mm	Inch		
V	FLDM 6X30	6	30	1,2	1,25	50
V	FLDM 6X45	6	45	1,8	1,56	50
V	FLDM 6X60 V	6	60	2,4	2,08	50
E3	FLDM 6X45 E3	6	45	1,8	1,56	50

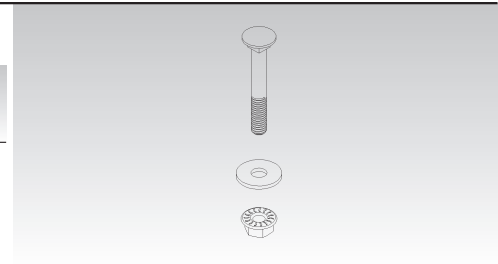

Threaded Rod, size M6

	model no.	length A		strength category	Weight per 100 pcs kg	Pack/ Box Qty
		mm	Inch			
★ V	M 6/1000	1000	39,4	4.6	21,72	25

Nuts and washers are included.

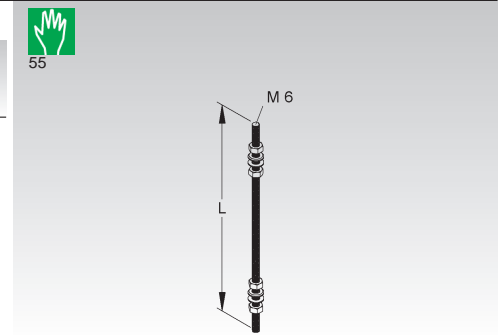

Threaded Rod, size M8

	model no.	length A		strength category	Weight per 100 pcs kg	Pack/ Box Qty
		mm	Inch			
V	M 8/1000	1000	39,4	4.6	35,1	25

Nuts and washers are included.

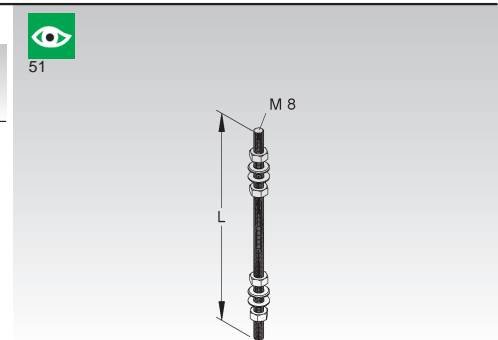

Threaded Rod, size M10

	model no.	length A		strength category	Weight per 100 pcs kg	Pack/ Box Qty
		mm	Inch			
V	M 10/1000	1000	39,4	4.6	56,4	25

Nuts and washers are included.

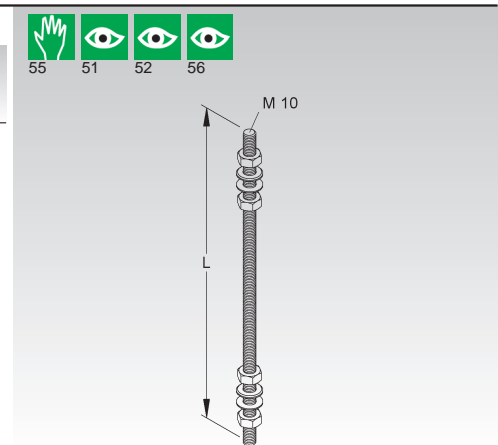

Threaded Rod, size M12

model no.	length A		strength category	Weight per 100 pcs kg	Pack/ Box Qty
	mm	Inch			
V M 12/1000	1000	39,4	4.6	75	20

Nuts and washers are included.



Large Diameter Washer

model no.	Diameter of mounting hole	width B		Weight per 100 pcs kg	Pack/ Box Qty
		mm	mm Inch		
V UGM 6	6,4	18 0,7	0,26	100	
V UGM 8	8,4	24 0,9	0,68	100	
V UGM 10	10,5	30 1,2	1,22	100	
V UGM 12 V	13	37 1,5	2,22	100	
F UGM 6 F	6,4	18 0,7	0,28	100	
F UGM 8 F	8,4	24 0,9	0,74	100	
F UGM 10 F	10,5	30 1,2	1,34	100	
F UGM 12 F	13	37 1,5	2,44	100	
E3 UGM 6 E3	6,4	18 0,7	0,26	100	
E3 UGM 8 E3	8,4	24 0,9	0,68	100	
E3 UGM 10 E3	10,5	30 1,2	1,22	100	
E3 UGM 12 E3	13	37 1,5	2,23	100	

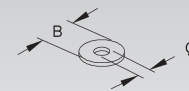

Hexagonal Nut

washer included

model no.	thread M	Weight per 100 pcs kg	Pack/ Box Qty
V SMU 8	8	0,77	50
V SMU 10	10	1,53	50
V SMU 12	12	2,32	40
E3 SMU 10 E3	10	1,53	50
E3 SMU 12 E3	12	2,25	40



Hexagonal Rod Coupling

model no.	thread M	length A		Weight per 100 pcs kg	Pack/ Box Qty
		mm	Inch		
V VBSM 8	8	40 1,6	1,80	50	
V VBSM 10	10	40 1,6	2,25	50	
V VBSM 12	12	40 1,6	7,00	50	

for coupling threaded rods

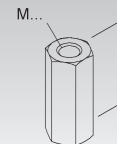

Serrated Washer

model no.	inner diameter		Weight per 100 pcs kg	Pack/ Box Qty
	mm	Inch		
V ZS M6	6,4 0,3	0,02	100	
V ZS M8	8,4 0,3	0,05	100	
V ZS M10	10,5 0,4	0,08	100	
V ZS M12	12,5 0,5	0,11	100	



SUPPORT SYSTEM

Nail Anchor

	model no.	thread M	clamping range mm	Weight per 100 pcs kg	Pack/Box Qty
V	DAM 6X5	6	≤ 5	1,38	50
V	DAM 6X10	6	≤ 10	1,30	50



Bolt Anchor

	model no.	thread M	clamping range mm	Weight per 100 pcs kg	Pack/Box Qty
V	DAZ 8X10	8	≤ 10	3,16	50
V	DAZ 10X10	10	≤ 10	6,33	50
V	DAZ 10X30	10	≤ 30	7,32	25
V	DAZ 12X10	12	≤ 10	10,27	20
V	DAZ 16X25	16	≤ 25	23,78	10

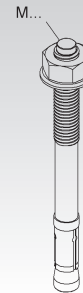
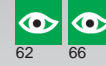

High performance steel anchor with washer and nut for cracked and non/cracked concrete (C20/25 to C50/60) as well as for natural stone with dense structure.

Please always follow the installation instructions and contact Niedax with any questions regarding technical specifications.

Edge Protection Strip

	model no.	color	clamping range mm	Weight per 100 m/kg	Pack/Box Qty
★	K10 RKBA 6	black	1-2	7,7	10 m
	K10 RKBA 10	black	0,75-4	15,0	10 m
	K10 RKBA 10 E4	black	0,75-4	15,0	10 m

temperature range -25°C to +70°C

RKBA 6

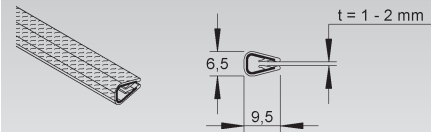

RKBA 10

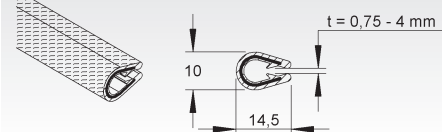

Edge Protection Strip

	model no.	color	clamping range mm	Weight per 100 m/kg	Pack/Box Qty
★	K10 RKBA 5	black	0,8-1,5	4,7	10 m

temperature range -25°C to +70°C

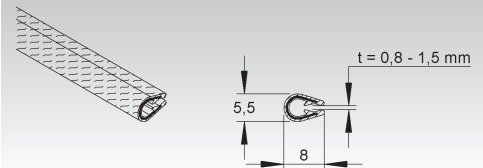

Edge Protection Ring

UV resistant

	model no.	color	inside height H mm Inch	inside dimension (B) mm Inch	Weight per 100 pcs kg	Pack/Box Qty
	K04 KSR 20 A	black	14,5 0,6	58 2,3	0,32	20
	K04 KSR 30 A	black	24,0 0,9	58 2,3	0,38	20

to protect cables at the knockouts of tray or surface metal raceways

Suitable for: RSV 50... distribution cable tray

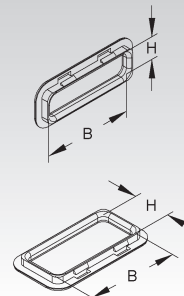

Edge Protection Ring

UV resistant

model no.	color	inside height H mm Inch	inside dimension (B) mm Inch	Weight per 100 pcs kg	Pack/Box Qty
K04 KSR 40 A	black	34,5 1,4	144,5 5,7	0,97	20

to protect cables at the knockouts of tray or surface metal raceways

Suitable for: RLCPV 85... OV and RSV 110... distribution cable tray

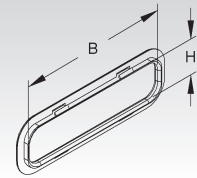

Punch and Die Set for hydraulic tools

model no.	height H mm Inch	width B mm Inch	Weight per 100 pcs kg	Pack/Box Qty
B BL 20.65	20 0,8	65 2,6	108	1
B BL 30.65	30 1,2	65 2,6	108	1

for punching square knockouts in mild steel of max. 2 mm thickness

Please install KSR...A edge protection rings to protect cables from damage.

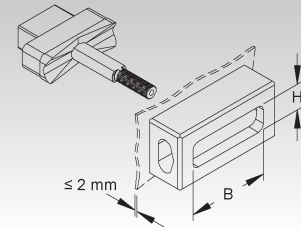

SUPPORT SYSTEM

Yoke-Clamp

with pressure cradle

model no.	for cable dia. mm	bolt head	thread M	Weight per 100 pcs kg	Pack/Box Qty
F BA 12	6 - 12	slotted hex head	6	2,36	100
F BA 14	10 - 14	slotted hex head	6	2,54	100
F BA 16	12 - 16	slotted hex head	6	2,72	100
F BA 18	14 - 18	slotted hex head	6	2,96	100
F BA 22	18 - 22	slotted hex head	6	3,38	100
F BA 26	22 - 26	slotted hex head	6	3,89	100
F BA 30	26 - 30	slotted hex head	6	4,32	100
F BA 34	30 - 34	slotted hex head	6	5,80	100
F BA 38	34 - 38	slotted hex head	6	7,83	100
F BA 42	38 - 42	slotted hex head	6	8,83	100
F BA 46	42 - 46	slotted hex head	8	9,91	100
F BA 50	46 - 50	slotted hex head	8	10,64	50
F BA 54	50 - 54	slotted hex head	8	11,32	50
F BA 58	54 - 58	slotted hex head	8	12,63	50
F BA 64	58 - 64	slotted hex head	8	13,36	50

for one cable

Suitable for: slot width 11-12 mm

Please order GWU... counter pressure cradles separately.

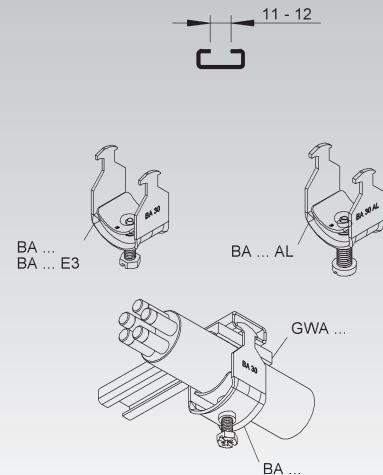

Yoke-Clamp

with plastic pressure cradle

model no.	for cable dia. mm	bolt head	thread M	Weight per 100 pcs kg	Pack/Box Qty
F BAK 14	10 - 14	slotted hex head	6	2,95	100
F BAK 18	14 - 18	slotted hex head	6	3,29	100
F BAK 22	18 - 22	slotted hex head	6	3,71	100
F BAK 26	22 - 26	slotted hex head	6	3,95	100
F BAK 30	26 - 30	slotted hex head	6	4,40	100
F BAK 34	30 - 34	slotted hex head	6	4,75	100
F BAK 38	34 - 38	slotted hex head	6	7,21	100
F BAK 42	38 - 42	slotted hex head	6	8,05	100
F BAK 46	42 - 46	slotted hex head	8	9,21	100
F BAK 50	46 - 50	slotted hex head	8	9,78	50
F BAK 54	50 - 54	slotted hex head	8	11,02	50
F BAK 58	54 - 58	slotted hex head	8	11,25	50
F BAK 64	58 - 64	slotted hex head	8	12,07	50

for one cable

Suitable for: slot width 11-12 mm

Please order GWU... counter pressure cradles separately.

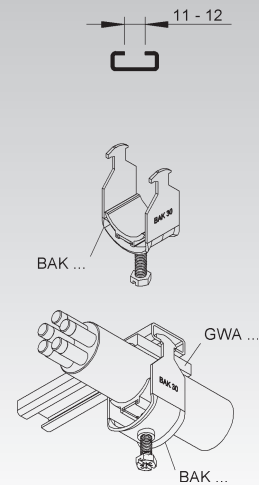

Yoke-Clamp

with pressure cradle

model no.	for cable dia. mm	bolt head	thread M	Weight per 100 pcs kg	Pack/Box Qty
F B 12	6 - 12	slotted hex head	6	2,57	100
F B 14	10 - 14	slotted hex head	6	2,78	100
F B 16	12 - 16	slotted hex head	6	2,92	100
F B 18	14 - 18	slotted hex head	6	3,14	100
F B 22	18 - 22	slotted hex head	6	3,56	100
F B 26	22 - 26	slotted hex head	6	4,10	100
F B 30	26 - 30	slotted hex head	6	4,58	100
F B 34	30 - 34	slotted hex head	6	6,07	100
F B 38	34 - 38	slotted hex head	6	8,07	100
F B 42	38 - 42	slotted hex head	6	8,61	100
F B 46	42 - 46	slotted hex head	8	9,97	100
F B 50	46 - 50	slotted hex head	8	10,55	50
F B 54	50 - 54	slotted hex head	8	11,27	50
F B 58	54 - 58	slotted hex head	8	11,82	50
F B 64	58 - 64	slotted hex head	8	12,47	50

for one cable

Suitable for: slot width 16-17 mm

Please order GWU... counter pressure cradles separately.

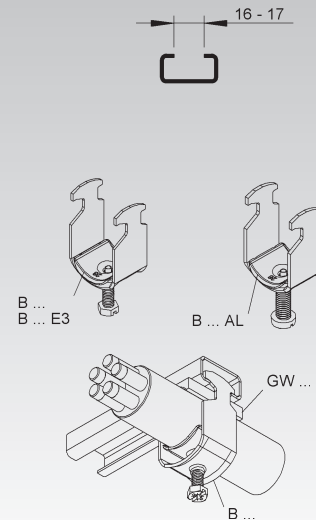

Yoke-Clamp

with plastic pressure cradle

model no.	for cable dia. mm	bolt head	thread M	Weight per 100 pcs kg	Pack/Box Qty
F BK 14	8 - 14	slotted hex head	6	3,42	100
F BK 18	14 - 18	slotted hex head	6	3,65	100
F BK 22	18 - 22	slotted hex head	6	3,92	100
F BK 26	22 - 26	slotted hex head	6	4,28	100
F BK 30	26 - 30	slotted hex head	6	4,67	100
F BK 34	30 - 34	slotted hex head	6	5,05	100
F BK 38	34 - 38	slotted hex head	6	7,37	100
F BK 42	38 - 42	slotted hex head	6	7,92	100
F BK 46	42 - 46	slotted hex head	8	9,30	100
F BK 50	46 - 50	slotted hex head	8	9,86	50
F BK 54	50 - 54	slotted hex head	8	10,63	50
F BK 58	54 - 58	slotted hex head	8	11,61	50
F BK 64	58 - 64	slotted hex head	8	12,55	50

for one cable

Suitable for: slot width 16-17 mm

Please order GWU... counter pressure cradles separately.

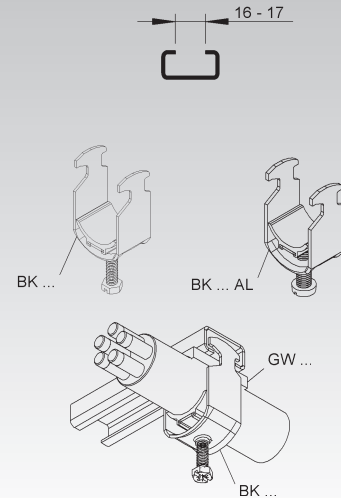

Yoke-Clamp

with pressure cradle

model no.	for cable dia. mm	bolt head	thread M	Weight per 100 pcs kg	Pack/Box Qty
F BU 12	6 - 12	slotted hex head	6	2,83	100
F BU 14	10 - 14	slotted hex head	6	3,16	100
F BU 16	12 - 16	slotted hex head	6	3,30	100
F BU 18	14 - 18	slotted hex head	6	3,46	100
F BU 22	18 - 22	slotted hex head	6	3,91	100
F BU 26	22 - 26	slotted hex head	6	4,33	100
F BU 30	26 - 30	slotted hex head	6	4,81	100
F BU 34	30 - 34	slotted hex head	6	6,06	100
F BU 38	34 - 38	slotted hex head	6	8,03	100
F BU 42	38 - 42	slotted hex head	6	8,61	100
F BU 46	42 - 46	slotted hex head	8	9,78	100
F BU 50	46 - 50	slotted hex head	8	10,31	50
F BU 54	50 - 54	slotted hex head	8	11,07	50
F BU 58	54 - 58	slotted hex head	8	11,70	50
F BU 64	58 - 64	slotted hex head	8	12,68	50

for one cable

Suitable for: slot width 18-22 mm

Please order GWU... counter pressure cradles separately.

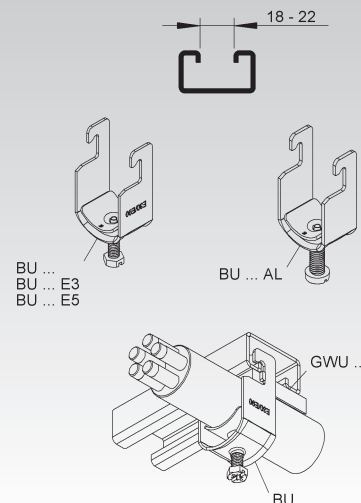

Yoke-Clamp

with plastic pressure cradle

model no.	for cable dia. mm	bolt head	thread M	Weight per 100 pcs kg	Pack/Box Qty
F BUK 14	8 - 14	slotted hex head	6	3,55	100
F BUK 18	14 - 18	slotted hex head	6	3,77	100
F BUK 22	18 - 22	slotted hex head	6	4,10	100
F BUK 26	22 - 26	slotted hex head	6	4,54	100
F BUK 30	26 - 30	slotted hex head	6	4,85	100
F BUK 34	30 - 34	slotted hex head	6	5,17	100
F BUK 38	34 - 38	slotted hex head	6	7,55	100
F BUK 42	38 - 42	slotted hex head	6	7,98	100
F BUK 46	42 - 46	slotted hex head	8	9,29	100
F BUK 50	46 - 50	slotted hex head	8	9,78	50
F BUK 54	50 - 54	slotted hex head	8	10,43	50
F BUK 58	54 - 58	slotted hex head	8	10,98	50
F BUK 64	58 - 64	slotted hex head	8	11,80	50

for one cable

Suitable for: slot width 18-22 mm

Please order GWU... counter pressure cradles separately.

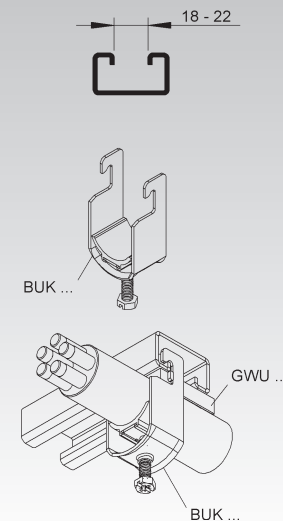

SUPPORT SYSTEM

Yoke Clamp for Angle Sections

with plastic pressure cradle

model no.	for cable dia.	bolt head	thread M	Weight per 100 pcs	Pack/Box Qty
	mm			kg	
F BWK 14	8 - 14	slotted hex head	6	4,68	100
F BWK 18	14 - 18	slotted hex head	6	4,93	100
F BWK 22	18 - 22	slotted hex head	6	5,21	100
F BWK 26	22 - 26	slotted hex head	6	5,65	100
F BWK 30	26 - 30	slotted hex head	6	5,90	100
F BWK 34	30 - 34	slotted hex head	6	6,26	100
F BWK 38	34 - 38	slotted hex head	6	8,79	100
F BWK 42	38 - 42	slotted hex head	6	9,22	100
F BWK 46	42 - 46	slotted hex head	8	10,61	100
F BWK 50	46 - 50	slotted hex head	8	10,94	50
F BWK 54	50 - 54	slotted hex head	8	11,59	50
F BWK 58	54 - 58	slotted hex head	8	12,09	50
F BWK 64	58 - 64	slotted hex head	8	12,96	50

for one cable

Please order GWU... counter pressure cradles separately.

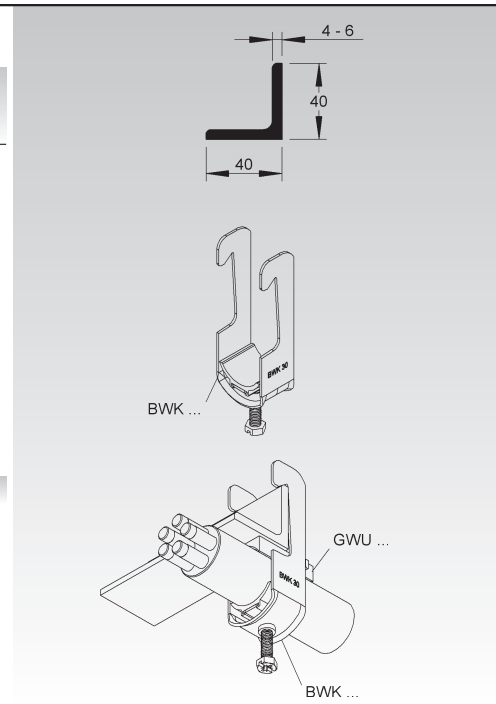

Counter Pressure Cradle for all Yoke-Clamps

model no.	similar to RAL	for cable dia.	length A	Weight per 100 pcs	Pack/Box Qty
		mm	mm Inch	kg	
K02 GWU 12	7035	6 - 12	40 1,6	0,08	100
K02 GWU 14	7035	10 - 14	40 1,6	0,10	100
K02 GWU 16	7035	12 - 16	40 1,6	0,12	100
K02 GWU 18	7035	14 - 18	40 1,6	0,13	100
K02 GWU 22	7035	18 - 22	40 1,6	0,23	100
K02 GWU 26	7035	22 - 26	40 1,6	0,28	100
K02 GWU 30	7035	26 - 30	40 1,6	0,37	100
K02 GWU 34	7035	30 - 34	40 1,6	0,42	100
K02 GWU 38	7035	34 - 38	40 1,6	0,60	50
K02 GWU 42	7035	38 - 42	40 1,6	0,66	50
K02 GWU 46	7035	42 - 46	40 1,6	0,73	50
K02 GWU 50	7035	46 - 50	40 1,6	0,81	50
K02 GWU 54	7035	50 - 54	45 1,8	1,27	50
K02 GWU 58	7035	54 - 58	45 1,8	1,42	50
K02 GWU 64	7035	58 - 64	45 1,8	1,53	50

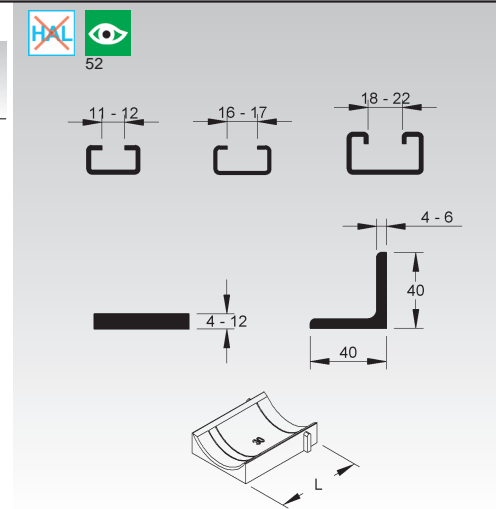

NOTES



NX *CITO* LINE

ONE CLICK - FINISHED!

➔ Easy Handling:

NX *CITO* wire mesh tray can be installed smoothly and quickly even in confined spaces.

➔ No need for bolts and splices:

NX *CITO* wire mesh trays are connected with a patented snap lock mechanism that ensures the same load rating as bolted splices.

➔ *NX* *CITO* Wire Mesh Tray is fully compatible with all existing accessories.

Grounding lugs, mounting plates for junction boxes ...



WIRE MESH TRAY SYSTEM

- Wire Mesh Tray
- Barrier Strips

- Covers
- Accessoires



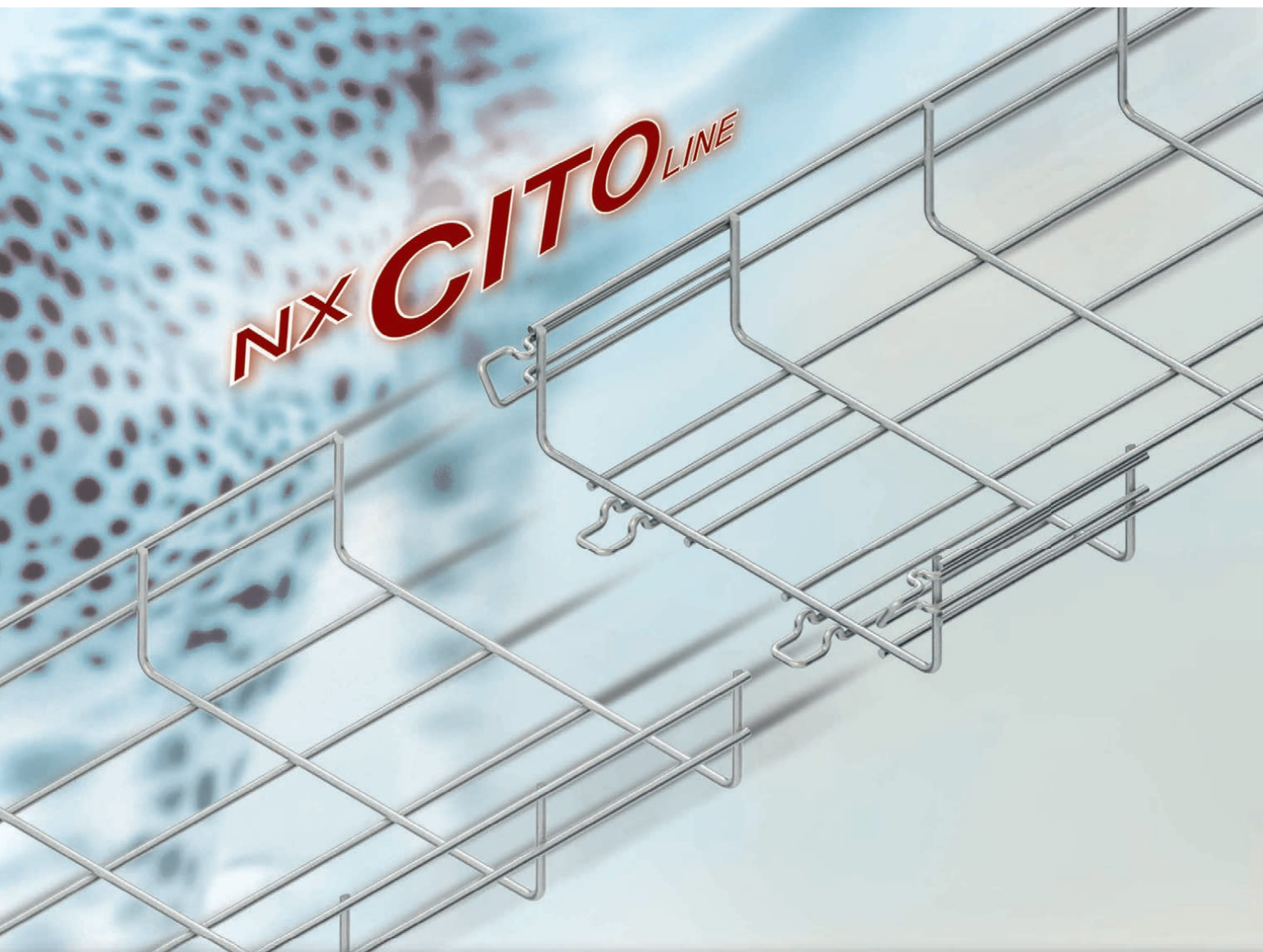

NX CITO LINE

Wire Mesh Tray is lightweight, flexible and easy to install. Due to its small surface area there is no accumulation of dirt or humidity. Cable ventilation is perfect. There is no need for long term advanced planning and ordering. Just get straight sections of tray, a few accessories like the universal splice kit and a bolt cutter and you are ready to go. All kinds of fittings can be done onsite easily. Wire Mesh Tray is available in many finishes and can be used in industrial and commercial environments, inside and outside.

WIRE MESH TRAY SYSTEM

Available Side Rail Heights

Height 54 mm	Nominal 2 inches	Height 60 mm	Nominal 2 3/8 inches	Height 105 mm	Nominal 4 inches	Height 110 mm	Nominal 4 3/8 inches	Height 160 mm	Nominal 6 inches
--------------------	------------------------	--------------------	----------------------------	---------------------	------------------------	---------------------	----------------------------	---------------------	------------------------

SYSTEM	★ Wire Mesh Tray	MTC 54...	Page 146
	★ Wire Mesh Tray	MTC 105...	Page 147
	Wire Mesh Tray	GR 60...	Page 149
	Wire Mesh Tray	GRS 60...	Page 150
	Wire Mesh Tray	GRS 110...	Page 151
	Wire Mesh Tray	GRS 160...	Page 151
ZUBEHÖR	Cover for Tray/Ladder	RD...	Page 152
	★ Retaining bracket	GRDHL 30 S	Page 152
	Cover for MTC Wire Mesh Tray	GTD...	Page 148*
	★ Cover Clamps for GTD Wire Mesh Cover	GTDC 54/105 E2	Page 148*
	Universal Splice Bolt	GRHKM 6X15...	Page 153*
	Universal Splice Plate	GRV 6...	Page 153*
	Boltless Splice Plate	GRVS 4 E3	Page 153
	★ Elbow Splice Clip	MTCA...	Page 153*
	Bendable Multifunction Splice Bar	GTVL 300...	Page 153*
	Square Splice Washer	GTL 20...	Page 153*
	U-Shaped Square Washer	GTL 30...	Page 154*
	Large Square Splice Washer/Clamping Bracket	GTL 40...	Page 154*
	Mushroom Head Bolt	FLM 6X20...	Page 154*
	Adjustable Splice Plate	GRGV 50...	Page 154*
	Elbow Splice Bar	GRWV 20/250...	Page 154*
	J - Hook Bolt	GRSM 6...	Page 154*
	Barrier Strip	RW...	Page 155*
	Splice Plate for Barrier Strip	RTV...	Page 155*
	Mounting Clamp for Barrier Strip	GRVC 14...	Page 155*
	Cable Drop Out	GTKA 50...	Page 155*
	Wire Mesh Mounting Bracket	GRBP 6...	Page 156*
	Universal Wire Mesh Mounting Bracket	GRWGK 10...	Page 156*
	Wire Mesh Center Hanger	GRKB 10...	Page 157*
	Wall and Box Mount Bracket for Wire Mesh Tray	GTMB 65...	Page 157*
	Wall and Box Mount Bracket	GTMB 50...	Page 158*
	Trapeze Hanger for Wire Mesh Tray	GTAB 8...	Page 159*
	Hanger for Wire Mesh Tray	GTTKS...	Page 159*
	Wall/Ceiling Bracket for Wire Mesh Tray	GTTKSU...	Page 160*
	★ C-Bracket for Mesh Tray	GTCB 50/...	Page 160*
	Center Hanger/Trapeze Support for Wire Mesh Basket	GTTW...	Page 160*
	★ Pedestal Clamp	DBSK 30.30-195-1.5	Page 161*
	★ Floor Stand	GRBS...	Page 161*

Please find the nominal dimensions of accessories in the chart section.

MTC ^{NX}CITO Wire Mesh Tray - fast and easy installed.

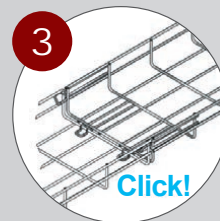
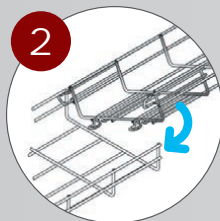
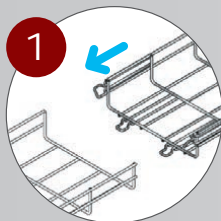

* Applicable with all edge heights



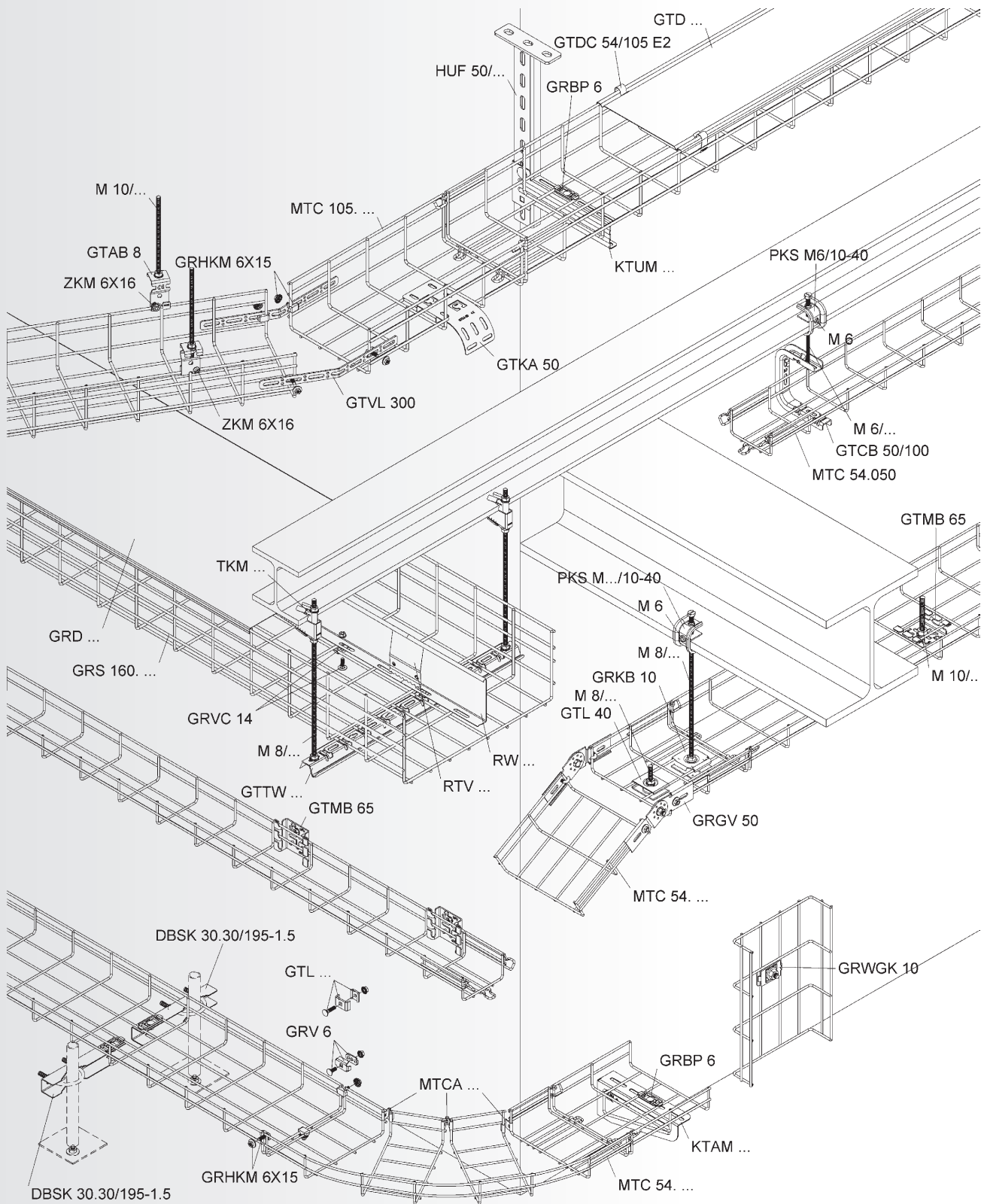

Wire Mesh Cable Tray Specifications:

➔ A. CABLE TRAY DESIGN

1. Wire mesh cable tray shall utilize high mechanical strength steel wire that is welded into a 2" x 4" (50 mm x 100 mm) grid system. This grid is then formed into channels, which support and carry cables and permit ventilation of cables and maximum heat dissipation.

➔ B. MATERIAL

1. **Electro-plated zinc galvanized: ASTM B633.**
To be applied to welded and formed wire mesh surfaces.
2. **Hot dipped galvanized steel.**
All trays to be hot-dipped galvanized after fabrication in accordance with ASTM A123.
3. **Stainless steel.**
All trays are to be constructed of AISI type 304 or type 316 stainless steel for maximum corrosion resistance
4. **Epoxy Powder Coated Paint:**
available on special request

➔ C. TRAY SIZE

1. **Height:** Trays shall have an overall height of 2.3", 4.3", and 6.3" (60, 110 and 160 mm)
2. **Width:** Widths shall be 2", 4", 6", 8", 12", 16", 18" 20" and 24" (60, 100, 150, 200, 300, 400, 450, 500 and 600 mm).
3. **Length:** Length shall be a nominal 10' or 3 meters.

➔ D. FITTINGS:

1. Shall be fabricated in the field by cutting wires with offset blade bolt cutters. Cuts shall be made in a manner reducing sharp edges and projections so they do not harm cables or installation personnel.
2. Dividers. Provide pre-galvanized steel, full depth divider strips to follow the contours of the mesh sections to allow different wiring systems to be run in the same tray.
3. Supports: Manufacturers specified supports and hardware are to be used for installation
4. Splices: Two options available, bolted type or non bolted to splice sections end to end, in pre-galvanized steel, hot dipped galvanized steel, and stainless steel.

➔ E. UL CLASSIFICATION

1. Straight sections shall be UL classified as an equipment grounding conductor

➔ F. DESIGN AND MANUFACTURE

1. GRX/GRSX series cable tray shall be manufactured by The Niedax Group.



➔ **Load/Span Class Designation in accordance with NEMA VE 1 and CSA E22.2 No. 126.1**

Niedax Series	Minimum Area		Load class in accordance to NEMA VE 1		
	(calculational) mm ² / in. ²	in accordance to NEMA VE 2 mm ² / in. ²	Rated Load Kg/m / lb./ft.	Support spacing m / ft.	Load/Span Class
GRX 60.060 E3	38 / 0.06	-	16.5 / 11.1	2 / 6.6	-
GRX 60.100 E3	58 / 0.09	-	16.5 / 11.1	2 / 6.6	-
GRX 60.150 E3	67 / 0.10	-	16.5 / 11.1	2 / 6.6	-
GRX 60.200 E3	77 / 0.12	-	16.5 / 11.1	2 / 6.6	-
GRX 60.300 E3	126 / 0.19	-	31.5 / 21.2	2 / 6.6	-
GRSX 60.100	75 / 0.12	-	25.5 / 17.1	2 / 6.6	-
GRSX 60.150	111 / 0.17	-	25.5 / 17.1	2 / 6.6	-
GRSX 60.200	127 / 0.20	-	25.5 / 17.1	2 / 6.6	-
GRSX 60.300	181 / 0.28	129 / 0.2	63 / 42.3	2 / 6.6	A
GRSX 60.400	217 / 0.34	129 / 0.2	63 / 42.3	2 / 6.6	A
GRSX 60.450	235 / 0.36	129 / 0.2	75 / 50.3	2 / 6.6	A
GRSX 60.500	253 / 0.39	129 / 0.2	63 / 42.3	2 / 6.6	A
GRSX 60.600	290 / 0.45	258 / 0.4	98 / 66.2	2 / 6.6	A
GRSX 110.100	127 / 0.19	-	53 / 35.8	2 / 6.6	-
GRSX 110.200	181 / 0.28	129 / 0.2	83.3 / 56	2 / 6.6	A
GRSX 110.300	217 / 0.34	129 / 0.2	83.3 / 56	2 / 6.6	A
GRSX 110.400	253 / 0.39	129 / 0.2	83.3 / 56	2 / 6.6	A
GRSX 110.450	271 / 0.42	258 / 0.4	83.3 / 56	2 / 6.6	A
GRSX 110.500	289 / 0.45	258 / 0.4	83.3 / 56	2 / 6.6	A
GRSX 110.600	326 / 0.50	258 / 0.4	103.3 / 69.4	2 / 6.6	A
GRSX 160.200 V	217 / 0.34	129 / 0.2	83.3 / 56	2 / 6.6	A
GRSX 160.300 V	253 / 0.39	129 / 0.2	83.3 / 56	2 / 6.6	A
GRSX 160.450 V	308 / 0.48	258 / 0.4	83.3 / 56	2 / 6.6	A
GRSX 160.600 V	362 / 0.56	258 / 0.4	123.3 / 82.9	2 / 6.6	A

WIRE MESH TRAY SYSTEM

Cito Line Wire Mesh Tray

with integrated snap lock mechanism

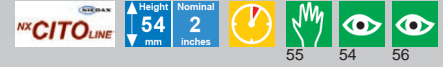

model no.	width inside B mm	steel wire-Ø lengthwise mm Inch	steel wire-Ø crosswise mm Inch	Weight per 100 kg	Pack/Box Qty
V MTC 54.050 V	50	3,90 0,2	3,90 0,2	64,5	2 x 3 m
V MTC 54.100 V	100	3,90 0,2	3,90 0,2	78,7	2 x 3 m
V MTC 54.150 V	150	3,90 0,2	3,90 0,2	93,7	2 x 3 m
V MTC 54.200 V	200	3,90 0,2	3,90 0,2	107,9	2 x 3 m
V MTC 54.300 V	300	4,82 0,2	4,82 0,2	209,7	2 x 3 m
V MTC 54.400 V	400	4,82 0,2	5,82 0,2	287,2	2 x 3 m
V MTC 54.500 V	500	4,82 0,2	5,82 0,2	337,5	2 x 3 m
V MTC 54.600 V	600	4,82 0,2	5,82 0,2	387,7	2 x 3 m
F MTC 54.050 F	50	3,90 0,2	3,90 0,2	71,0	2 x 3 m
F MTC 54.100 F	100	3,90 0,2	3,90 0,2	86,6	2 x 3 m
F MTC 54.150 F	150	3,90 0,2	3,90 0,2	103,0	2 x 3 m
F MTC 54.200 F	200	3,90 0,2	3,90 0,2	118,7	2 x 3 m
F MTC 54.300 F	300	4,82 0,2	4,82 0,2	230,7	2 x 3 m
F MTC 54.400 F	400	4,82 0,2	5,82 0,2	315,9	2 x 3 m
F MTC 54.500 F	500	4,82 0,2	5,82 0,2	371,2	2 x 3 m
F MTC 54.600 F	600	4,82 0,2	5,82 0,2	426,4	2 x 3 m
E3 MTC 54.050 E3	50	3,90 0,2	3,90 0,2	65,9	2 x 3 m
E3 MTC 54.100 E3	100	3,90 0,2	3,90 0,2	80,4	2 x 3 m
E3 MTC 54.150 E3	150	3,90 0,2	3,90 0,2	95,7	2 x 3 m
E3 MTC 54.200 E3	200	3,90 0,2	3,90 0,2	110,2	2 x 3 m
E3 MTC 54.300 E3	300	4,82 0,2	4,82 0,2	214,3	2 x 3 m
E3 MTC 54.400 E3	400	4,82 0,2	5,82 0,2	293,4	2 x 3 m
E3 MTC 54.500 E3	500	4,82 0,2	5,82 0,2	344,8	2 x 3 m
E3 MTC 54.600 E3	600	4,82 0,2	5,82 0,2	396,1	2 x 3 m
E4 MTC 54.050 E4	50	3,90 0,2	3,90 0,2	65,9	2 x 3 m
E4 MTC 54.100 E4	100	3,90 0,2	3,90 0,2	80,4	2 x 3 m
E4 MTC 54.150 E4	150	3,90 0,2	3,90 0,2	95,7	2 x 3 m
E4 MTC 54.200 E4	200	3,90 0,2	3,90 0,2	110,2	2 x 3 m
E4 MTC 54.300 E4	300	4,82 0,2	4,82 0,2	214,3	2 x 3 m
E4 MTC 54.400 E4	400	4,82 0,2	5,82 0,2	293,4	2 x 3 m
E4 MTC 54.500 E4	500	4,82 0,2	5,82 0,2	344,8	2 x 3 m
E4 MTC 54.600 E4	600	4,82 0,2	5,82 0,2	396,1	2 x 3 m

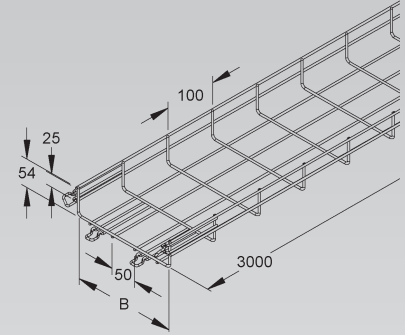

Load Chart: q = uniformly distributed load (tested according to DIN EN IEC 61537 standard)

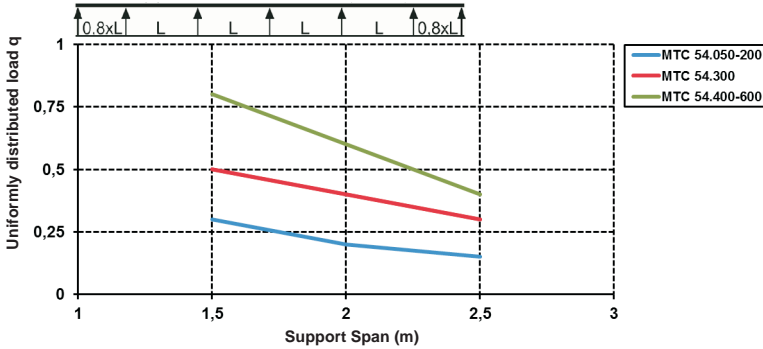

Specified load ratings are independent of splice plate location.



Cito Line Wire Mesh Tray

with integrated snap lock mechanism

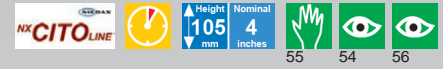

model no.	width inside B mm	steel wire-Ø lengthwise mm Inch	steel wire-Ø crosswise mm Inch	Weight per 100 kg	Pack/Box Qty
★ V MTC 105.100 V	100	3,90 0,2	3,90 0,2	107,1	2 x 3 m
★ V MTC 105.150 V	150	3,90 0,2	3,90 0,2	122,1	2 x 3 m
★ V MTC 105.200 V	200	4,82 0,2	4,82 0,2	209,7	2 x 3 m
★ V MTC 105.300 V	300	4,82 0,2	5,82 0,2	287,2	2 x 3 m
★ V MTC 105.400 V	400	4,82 0,2	5,82 0,2	337,5	2 x 3 m
★ V MTC 105.500 V	500	4,82 0,2	5,82 0,2	387,7	2 x 3 m
★ V MTC 105.600 V	600	4,82 0,2	5,82 0,2	437,8	2 x 3 m
★ F MTC 105.100 F	100	3,90 0,2	3,90 0,2	117,8	2 x 3 m
★ F MTC 105.150 F	150	3,90 0,2	3,90 0,2	134,3	2 x 3 m
★ F MTC 105.200 F	200	4,82 0,2	4,82 0,2	230,7	2 x 3 m
★ F MTC 105.300 F	300	4,82 0,2	5,82 0,2	315,9	2 x 3 m
★ F MTC 105.400 F	400	4,82 0,2	5,82 0,2	371,2	2 x 3 m
★ F MTC 105.500 F	500	4,82 0,2	5,82 0,2	426,4	2 x 3 m
★ F MTC 105.600 F	600	4,82 0,2	5,82 0,2	481,6	2 x 3 m
★ E3 MTC 105.100 E3	100	3,90 0,2	3,90 0,2	109,9	2 x 3 m
★ E3 MTC 105.150 E3	150	3,90 0,2	3,90 0,2	125,2	2 x 3 m
★ E3 MTC 105.200 E3	200	4,82 0,2	4,82 0,2	215,1	2 x 3 m
★ E3 MTC 105.300 E3	300	4,82 0,2	5,82 0,2	294,5	2 x 3 m
★ E3 MTC 105.400 E3	400	4,82 0,2	5,82 0,2	346,1	2 x 3 m
★ E3 MTC 105.500 E3	500	4,82 0,2	5,82 0,2	397,6	2 x 3 m
★ E3 MTC 105.600 E3	600	4,82 0,2	5,82 0,2	449,0	2 x 3 m
★ E4 MTC 105.100 E4	100	3,90 0,2	3,90 0,2	109,9	2 x 3 m
★ E4 MTC 105.150 E4	150	3,90 0,2	3,90 0,2	125,2	2 x 3 m
★ E4 MTC 105.200 E4	200	4,82 0,2	4,82 0,2	215,1	2 x 3 m
★ E4 MTC 105.300 E4	300	4,82 0,2	5,82 0,2	294,5	2 x 3 m
★ E4 MTC 105.400 E4	400	4,82 0,2	5,82 0,2	346,1	2 x 3 m
★ E4 MTC 105.500 E4	500	4,82 0,2	5,82 0,2	397,6	2 x 3 m
★ E4 MTC 105.600 E4	600	4,82 0,2	5,82 0,2	449,0	2 x 3 m

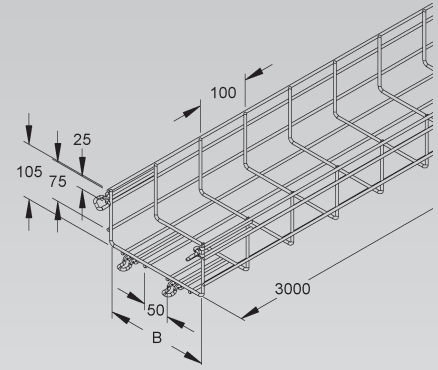

Load Chart: q = uniformly distributed load (tested according to DIN EN IEC 61537 standard)

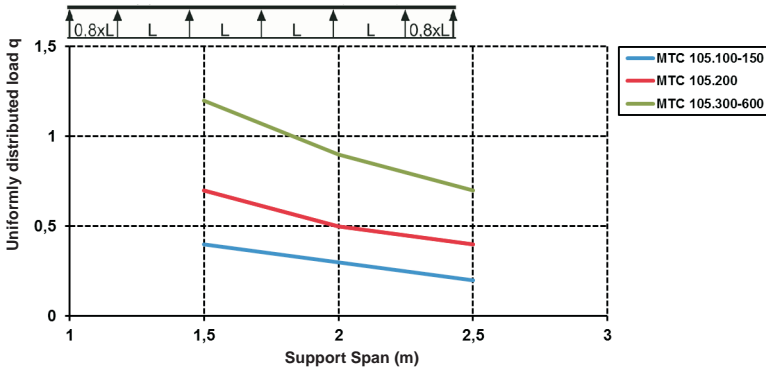

Specified load ratings are independent of splice plate location.

WIRE MESH TRAY SYSTEM

Cover for MTC Wire Mesh Tray

	model no.	width B		Weight per 100 kg	Pack/Box Qty
		mm	Inch		
S	GTD 50 S	50	2	36,0	3 m
S	GTD 100 S	100	3,9	55,3	3 m
S	GTD 150 S	150	5,9	75,0	3 m
S	GTD 200 S	200	7,9	114,0	3 m
S	GTD 300 S	300	11,8	200,0	3 m
S	GTD 400 S	400	15,7	343,0	3 m
S	GTD 500 S	500	19,7	421,0	3 m
S	GTD 600 S	600	23,6	500,0	3 m
F	GTD 50 F	50	2	45,0	3 m
F	GTD 100 F	100	3,9	73,0	3 m
F	GTD 150 F	150	5,9	96,0	3 m
F	GTD 200 F	200	7,9	124,8	3 m
F	GTD 300 F	300	11,8	220,8	3 m
F	GTD 400 F	400	15,7	377,0	3 m
F	GTD 500 F	500	19,7	460,0	3 m
F	GTD 600 F	600	23,6	550,0	3 m
E3	GTD 50 E3	50	2	58,0	3 m
E3	GTD 100 E3	100	3,9	90,2	3 m
E3	GTD 150 E3	150	5,9	122,2	3 m
E3	GTD 200 E3	200	7,9	154,2	3 m
E3	GTD 300 E3	300	11,8	218,2	3 m
E3	GTD 400 E3	400	15,7	352,8	3 m
E3	GTD 500 E3	500	19,7	432,8	3 m
E3	GTD 600 E3	600	23,6	512,8	3 m
E4	GTD 50 E4	50	2	58,0	3 m
E4	GTD 100 E4	100	3,9	90,2	3 m
E4	GTD 150 E4	150	5,9	122,2	3 m
E4	GTD 200 E4	200	7,9	154,2	3 m
E4	GTD 300 E4	300	11,8	218,2	3 m
E4	GTD 400 E4	400	15,7	352,0	3 m
E4	GTD 500 E4	500	19,7	432,8	3 m
E4	GTD 600 E4	600	23,6	503,0	3 m

GTD... covers can only be used with MTC... type basket tray. Will not work with GR... or GRS... type tray.

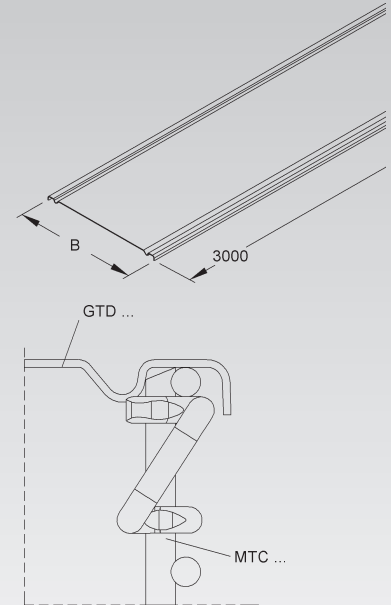

Cover Clamps for GTD Wire Mesh Covers

	model no.	Weight per 100	Pack/Box Qty
		kg	
★	E2	GTDC 54/105 E2	0,5 100

Cover clamps can be used only for a combination of MTC... trays and GTD... covers.

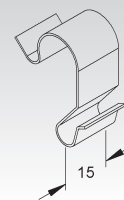

Wire Mesh Tray

model no.	height H mm Inch	width B mm Inch	Steel wire- Ø mm	Weight per 100 kg	Pack/ Box Qty
E3 GR 60.060 E3	60 2,4	60 2,4	3,5	42,56	2 x 3 m

Load Chart: q = uniformly distributed load (tested according to DIN EN IEC 61537 standard)

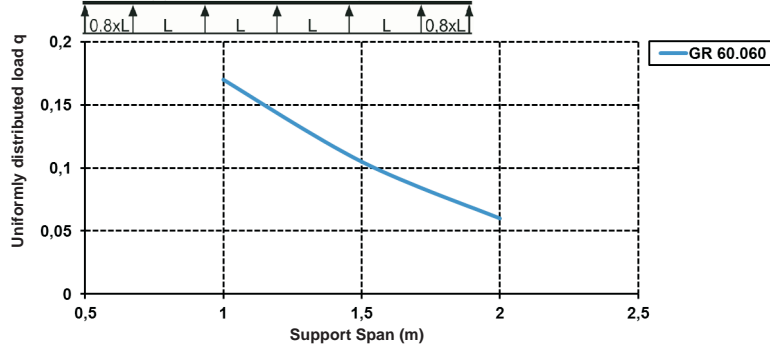

Specified load ratings are independent of splice plate location.

Height 60 mm
Nominal 2 3/8 inches

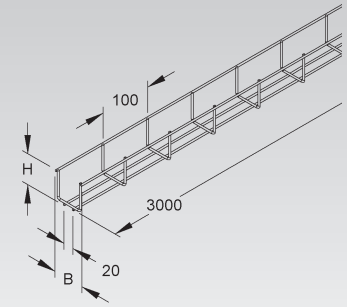

Wire Mesh Tray

model no.	height H mm Inch	width B mm Inch	Steel wire- Ø mm	Weight per 100 m kg	Pack/ Box Qty
E3 GR 60.100 E3	60 2,4	100 3,9	3,5	60,87	2 x 3 m
E3 GR 60.150 E3	60 2,4	150 5,9	3,5	72,41	2 x 3 m
E3 GR 60.200 E3	60 2,4	200 7,9	3,5	83,95	2 x 3 m
E3 GR 60.300 E3	60 2,4	300 11,8	4,0	139,45	2 x 3 m

Load Chart: q = uniformly distributed load (tested according to DIN EN IEC 61537 standard)

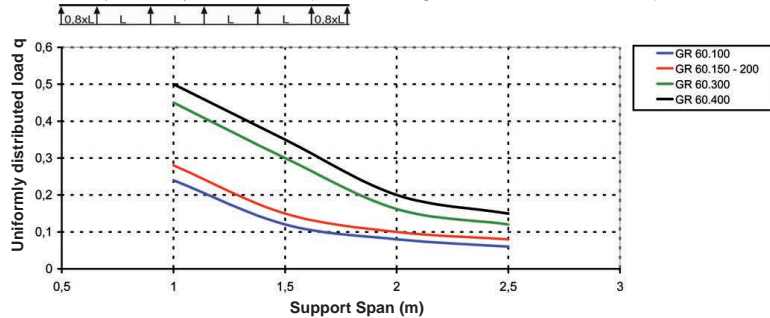

Specified load ratings are independent of splice plate location.

Height 60 mm
Nominal 2 3/8 inches
55 54

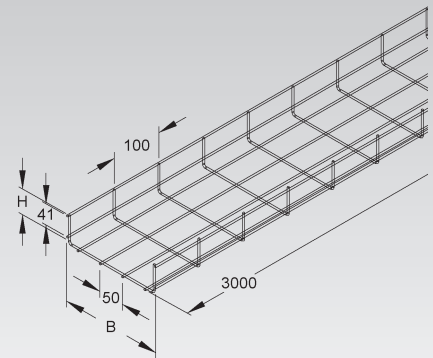

WIRE MESH TRAY SYSTEM

Wire Mesh Tray

model no.	height H	width B	Steel wire- Ø	Weight per 100 m kg	Pack/ Box Qty
	mm Inch	mm Inch	mm		
GRS 60.060	60 2,4	60 2,4	4	54,83	2 x 3 m

Splice plates have to be ordered separately.

Load Chart: q = uniformly distributed load (tested according to DIN EN IEC 61537 standard)

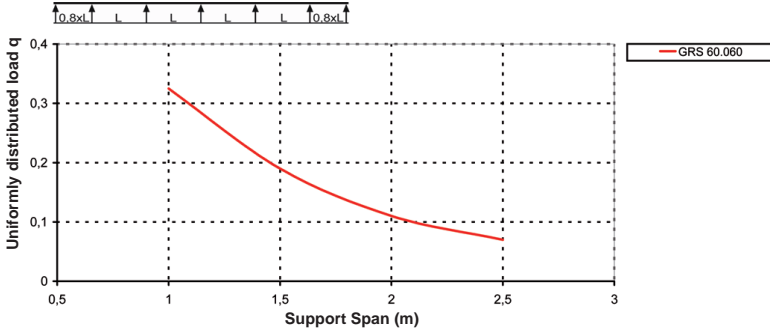

Specified load ratings are independent of splice plate location.

Consult factory for availability of GRS tray in stainless AISI 304 & 316.

Height 60 mm
Nominal 2 3/8 inches

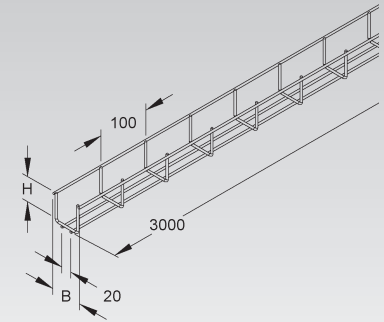

Wire Mesh Tray

model no.	height H	width B	Steel wire- Ø	dist. A	Weight per 100 m kg	Pack/ Box Qty
	mm Inch	mm Inch	mm	mm Inch		
GRS 60.100	60 2,4	100 3,9	4,0	40,0 1,6	78,97	2 x 3 m
GRS 60.150	60 2,4	150 5,9	4,5	37,5 1,5	118,32	2 x 3 m
GRS 60.200	60 2,4	200 7,9	4,5	37,5 1,5	137,27	2 x 3 m
GRS 60.300	60 2,4	300 11,8	4,8	37,5 1,5	199,37	2 x 3 m
GRS 60.400	60 2,4	400 15,7	4,8	37,5 1,5	241,92	2 x 3 m
GRS 60.450	60 2,4	450 17,7	4,8	37,5 1,5	263,49	2 x 3 m
GRS 60.500	60 2,4	500 19,7	4,8	37,5 1,5	285,63	2 x 3 m
GRS 60.600	60 2,4	500 19,7	4,8	37,5 1,5	328,77	2 x 3 m

Splice plates have to be ordered separately.

Load Chart: q = uniformly distributed load (tested according to DIN EN IEC 61537 standard)

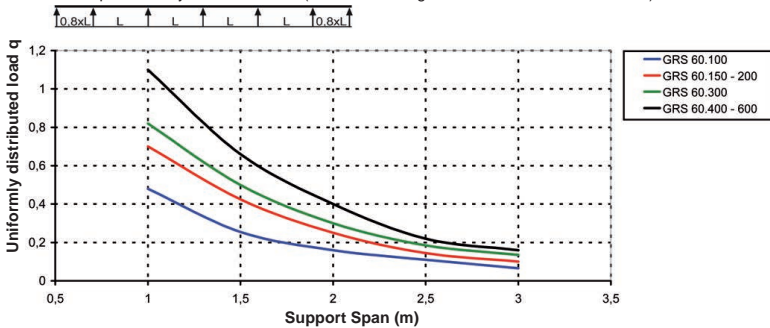

Specified load ratings are independent of splice plate location.

Consult factory for availability of GRS tray in stainless AISI 304 & 316.

Height 60 mm
Nominal 2 3/8 inches



55 54 61

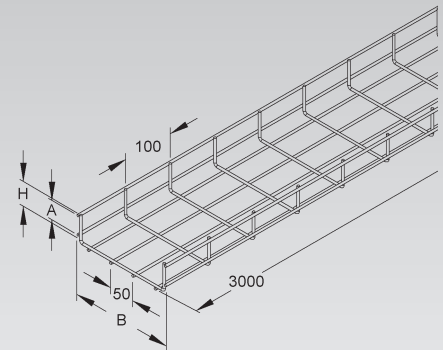

Wire Mesh Tray

model no.	height H	width B	thick-ness t	Weight per 100 m kg	Pack/Box Qty
	mm Inch	mm Inch	mm		
✓ GRS 110.100	110 4,3	100 3,9	4,5	137,04	2 x 3 m
✓ GRS 110.150	110 4,3	150 5,9	4,5	156,00	2 x 3 m
✓ GRS 110.200	110 4,3	200 7,9	4,8	198,78	2 x 3 m
✓ GRS 110.300	110 4,3	300 11,8	4,8	241,93	2 x 3 m
✓ GRS 110.400	110 4,3	400 15,7	4,8	285,07	2 x 3 m
✓ GRS 110.450	110 4,3	450 17,7	4,8	306,64	2 x 3 m
✓ GRS 110.500	110 4,3	500 19,7	4,8	328,22	2 x 3 m
✓ GRS 110.600	110 4,3	600 23,6	4,8	371,36	2 x 3 m

Height 110 mm
Nominal 4 3/8 inches
Eye icon
61

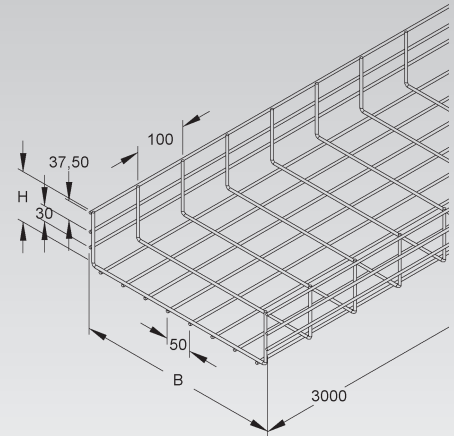

Splice plates have to be ordered separately.

Load Chart: q = uniformly distributed load (tested according to DIN EN IEC 61537 standard)

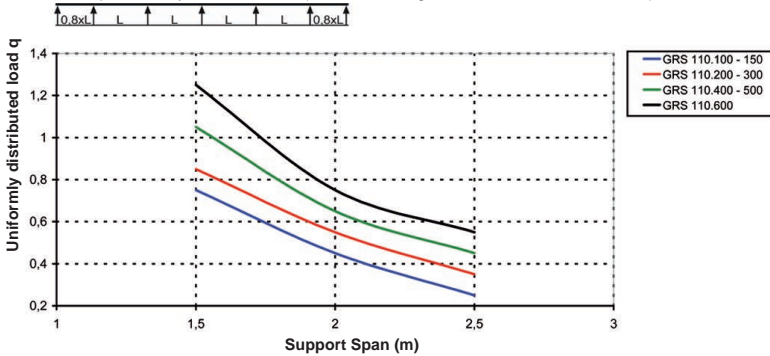

Specified load ratings are independent of splice plate location.
Consult factory for availability of GRS tray in stainless AISI 304 & 316.

Wire Mesh Tray

model no.	height H	width B	thick-ness t	Weight per 100 m kg	Pack/Box Qty
	mm Inch	mm Inch	mm		
✓ GRS 160.200 V	160 6,3	200 7,9	4,8	241,92	2 x 3 m
✓ GRS 160.300 V	160 6,3	300 11,8	4,8	285,07	2 x 3 m
✓ GRS 160.400 V	160 6,3	400 15,7	4,8	350,00	2 x 3 m
✓ GRS 160.450 V	160 6,3	450 17,7	4,8	350,00	2 x 3 m
✓ GRS 160.500 V	160 6,3	500 19,7	4,8	380,00	2 x 3 m
✓ GRS 160.600 V	160 6,3	600 23,6	4,8	413,00	2 x 3 m

Height 160 mm
Nominal 6 inches
Eye icon
61

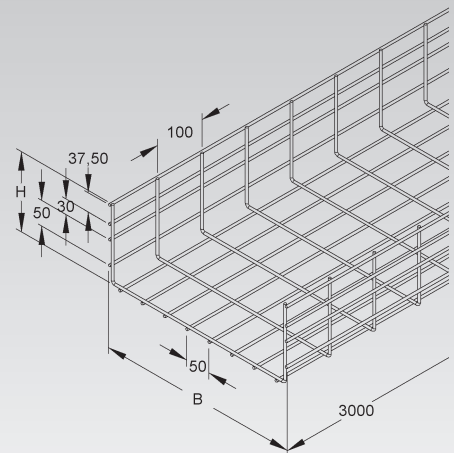

Splice plates have to be ordered separately.

Load Chart: q = uniformly distributed load (tested according to DIN EN IEC 61537 standard)

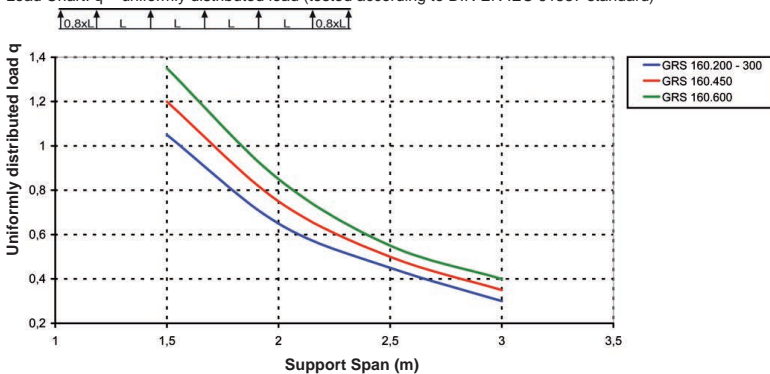

Specified load ratings are independent of splice plate location.
Consult factory for availability of GRS tray in stainless AISI 304 & 316.

WIRE MESH TRAY SYSTEM

Cover

model no.	inside dimension (B) mm Inch	Weight per 100 m kg	Pack/Box Qty
S RD 100	100 3,9	73,00	2 x 3 m
S RD 150	150 5,9	102,42	2 x 3 m
S RD 300	300 11,8	228,80	2 x 3 m
S RD 400	400 15,7	332,70	2 x 3 m
S RD 500	500 19,7	411,20	2 x 3 m
S RD 600	600 23,6	489,70	2 x 3 m

Suitable for: all straight sections of cable tray (other than RSV 50...), Wire Mesh Tray as well as for KL... cable ladders

For outdoor service covers need to be secured against windloads using heavy duty cover clamps or steel cable ties.

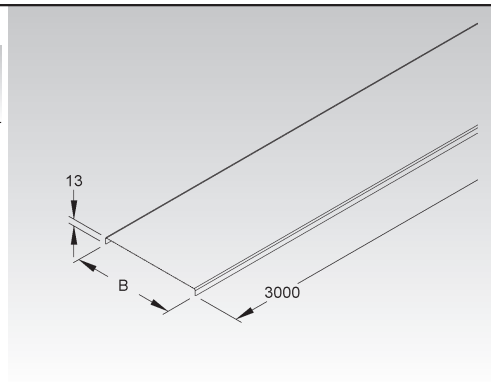

Retaining bracket

model no.	Weight per 100 kg	Pack/Box Qty
S GRDHL 30 S	3,27	50

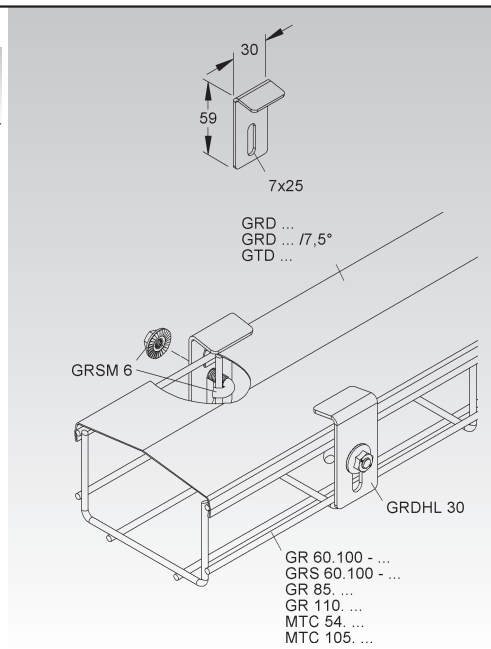

Universal Splice Bolt

model no.	strength category	Weight per 100 pcs kg	Pack/Box Qty
V GRHKM 6X15 V	8.8	1,83	50
F GRHKM 6X15 F	8.8	1,83	50
E3 GRHKM 6X15 E3	70	1,82	50

for making straight runs of wire mesh tray and fittings for wire mesh tray

Suitable for: Wire Mesh Tray

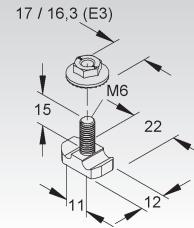
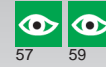

Universal Splice Plate

model no.	Weight per 100 pc./kg	Pack/Box Qty
S GRV 6	2,69	50
F GRV 6 F	2,69	50
E3 GRV 6 E3	2,80	20
E5 GRV 6 E5	2,63	20

Suitable for: Wire Mesh Tray



Boltless Splice Plate

model no.	height H	length A	for wire gauge	Weight per 100 pcs kg	Pack/Box Qty
E3 GRVS 4 E3	37 1,5	220 8,7	3,5 - 4,0	8,23	20

Suitable for: works only with GR... type wire mesh tray

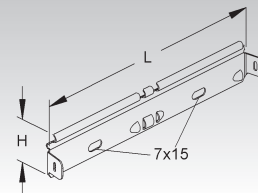

Elbow Splice Clip

model no.	for wire gauge	Weight per 100 kg	Pack/Box Qty
E3 MTCA 4 E3	4	1	50
E3 MTCA 5 E3	5	1	50

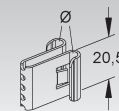

Bendable Multifunction Splice Bar

model no.	Weight per 100 kg	Pack/Box Qty
V GTVL 300 V	8	50
E3 GTVL 300 E3	8	50

Suitable for: making elbows or tee-fittings
Available also in 450 and 600 mm length.
GRSM 6 hardware not included.

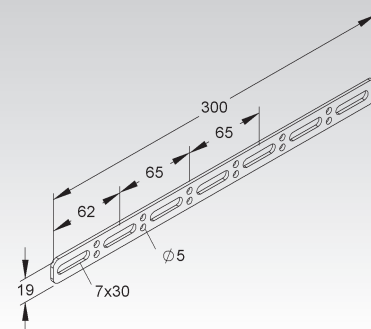
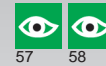

Square Splice Washer

model no.	Weight per 100 kg	Pack/Box Qty
V GTL 20 V	0,6	50
FG GTL 20 FG	0,9	50
E3 GTL 20 E3	0,6	50
E4 GTL 20 E4	0,6	50

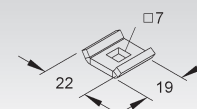
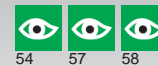

WIRE MESH TRAY SYSTEM ACCESSOIRES

U-Shaped Square Washer

model no.	Weight per 100 kg	Pack/Box Qty
V GTL 30 V	1,5	50
FG GTL 30 FG	1,5	50
E3 GTL 30 E3	1,5	50
E4 GTL 30 E4	1,5	50

Use GTL 20 and GTL 30 with FLM 6X20 as heavy duty splicekit.

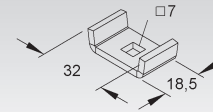
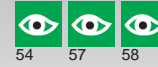

Large Square Splice Washer/Clamping Bracket

model no.	Weight per 100 kg	Pack/Box Qty
V GTL 40 V	3,6	50
FG GTL 40 FG	3,6	50
E3 GTL 40 E3	4,0	50
E4 GTL 40 E4	3,6	50

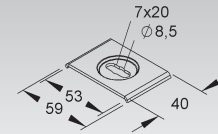

Mushroom Head Bolt

serrated flange nut included

model no.	thread M	length A	strength category	Weight per 100 kg	Pack/Box Qty
		mm Inch		kg	
G FLM 6X20 G	6	20 0,8	-	0,9	100
FG FLM 6X20 FG	6	20 0,8	-	0,7	100
E4 FLM 6X20 E4	6	20 0,8	-	0,9	100

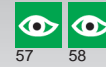

Adjustable Splice Plate

model no.	Weight per 100 pcs kg	Pack/Box Qty
S GRGV 50	11	10
F GRGV 50 F	12	10
E3 GRGV 50 E3	11	10

2 pieces required per joint

GRSM 6 hardware not included.

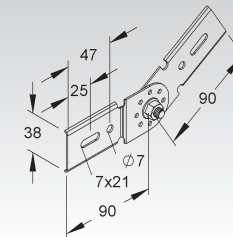

Elbow Splice Bar

model no.	height H	width B	Weight per 100 pc./kg	Pack/Box Qty
	mm Inch	mm Inch	kg	
F GRWV 20/250 F	20 0,8	250 9,8	17,20	20
G GRWV 20/250 G	20 0,8	250 9,8	21,82	20
E5 GRWV 20/250 E5	20 0,8	250 9,8	25,47	20

GRSM 6 hardware not included.

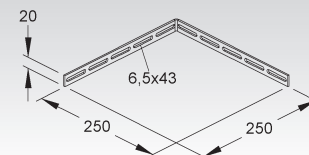
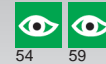

J-Hook Bolt

model no.	thread M	Weight per 100 pcs kg	Pack/Box Qty
V GRSM 6 V	6	1,16	50
F GRSM 6 F	6	1,16	50
E3 GRSM 6 E3	6	1,15	50

for attaching wire mesh tray

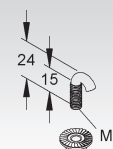

Barrier Strip

model no.	height H	thick- ness t	Weight per 100 m/ kg	Pack/ Box Qty
	mm Inch	mm		
S RW 60	55 2,2	0,75	49,86	10 x 3 m
S RW 110	98 3,9	0,90	90,37	10 x 3 m
F RW 60 F	55 2,2	0,75	54,87	10 x 3 m
F RW 110 F	98 3,9	0,90	99,30	10 x 3 m
E3 RW 60 E3	55 2,2	0,80	53,48	10 x 3 m
E3 RW 110 E3	98 3,9	0,90	90,94	10 x 3 m
E5 RW 60 E5	55 2,2	0,80	53,86	10 x 3 m
E5 RW 110 E5	98 3,9	0,90	81,25	10 x 3 m

to separate wires and cables of different voltage levels or with different functions
Flange with slotted holes 7x38 mm, spacing 100 mm.

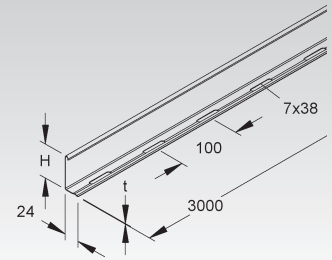
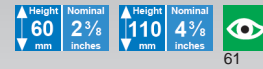

Splice Plate for Barrier Strip

model no.	height H	length A	Weight per 100 pcs kg	Pack/ Box Qty
	mm Inch	mm Inch		
E2 RTV 60 E2	54,5 2,1	80 3,1	1,39	20
E2 RTV 110 E2	97,5 3,8	80 3,1	2,50	20

for positive locking connections and proper bonding of barrier strips

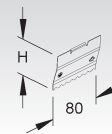
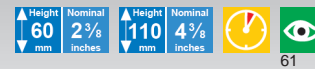

Mounting Clamp for Barrier Strip

model no.	Weight per 100 pcs/ kg	Pack/ Box Qty
S GRVC 14	2,24	50
F GRVC 14 F	2,36	50
E3 GRVC 14 E3	2,26	20
E5 GRVC 14 E5	2,28	20

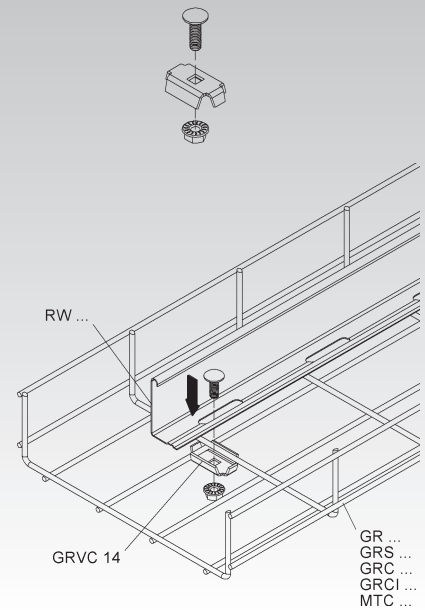

Cable Drop Out

model no.	Weight per 100 pcs/ kg	Pack/ Box Qty
S GTKA 50 S	16,5	10
F GTKA 50 F	17,6	10
E3 GTKA 50 E3	14,0	10
E4 GTKA 50 E4	14,0	10

Suitable for: MTC... and GRS... wire mesh tray

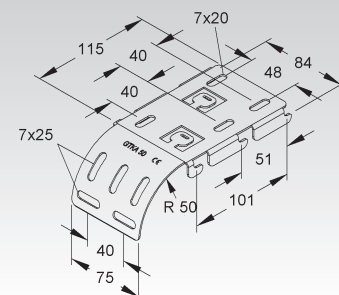

WIRE MESH TRAY SYSTEM ACCESSOIRES

Wire Mesh Mounting Bracket

model no.	Weight per 100 pcs kg	Pack/Box Qty
S GRBP 6 S	1,20	50
F GRBP 6 F	2,00	50
E3 GRBP 6 E3	1,12	50

Suitable for: GR... and GRS... wire mesh tray

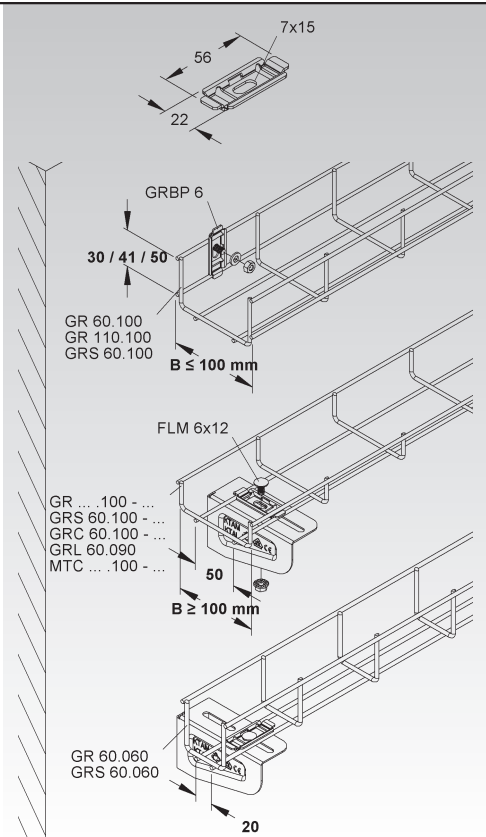

Universal Wire Mesh Mounting Bracket

model no.	Weight per 100 pcs kg	Pack/Box Qty
S GRWGK 10 S	5,8	25
E3 GRWGK 10 E3	5,8	25

Can be used for all kinds of wire mesh tray from wire gauge 3.0 mm to 6.0 mm.

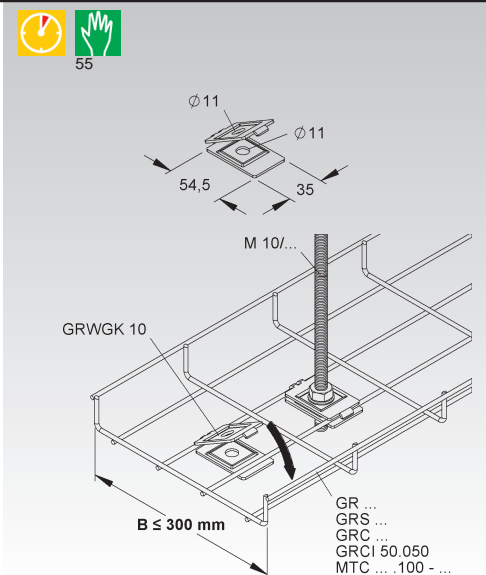

Wire Mesh Center Hanger

	model no.	Weight per 100 pc. kg	Pack/Box Qty
S	GRKB 10	10	25
F	GRKB 10 F	10	25



56

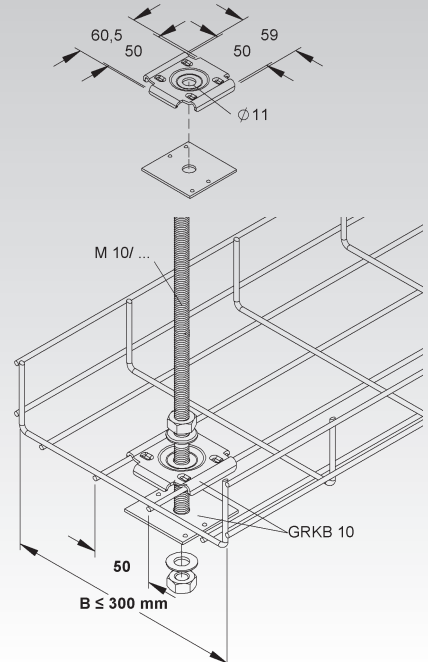

Wall and Box Mount Bracket for MTC Wire Mesh Tray

	model no.	Weight per 100 kg	Pack/Box Qty
S	GTMB 65 S	8,6	20
FG	GTMB 65 FG	6,5	20
E3	GTMB 65 E3	9,0	20
E4	GTMB 65 E4	9,0	20



55

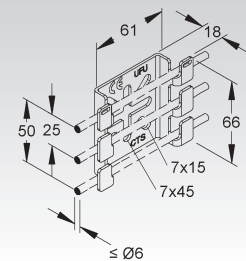

Suitable for: MTC tray only
Does not work with GR... or GRS... tray!

WIRE MESH TRAY SYSTEM ACCESSOIRES

Wall and Box Mount Bracket

model no.	Weight per 100 pcs kg	Pack/Box Qty
S GRMB 50	8,5	20
E3 GRMB 50 E3	8,5	20

Suitable for: GR... and GRS... tray only

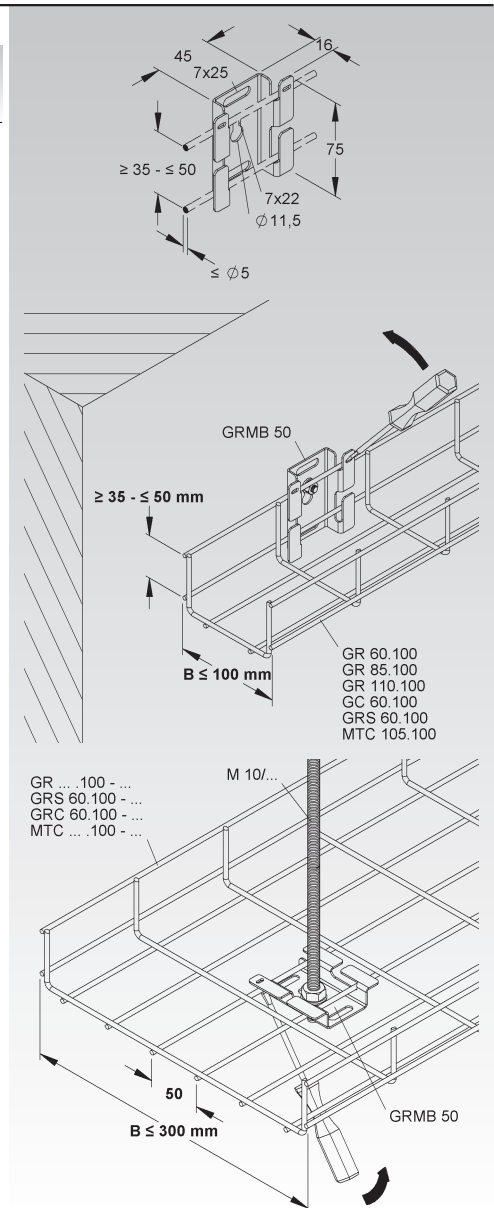

Trapeze Hanger for Wire Mesh Tray

model no.	Weight per 100	Pack/Box Qty
	kg	
S GTAB 8 S	7,0	20
F GTAB 8 F	7,0	20
E3 GTAB 8 E3	7,0	20
E4 GTAB 8 E4	5,7	20



56

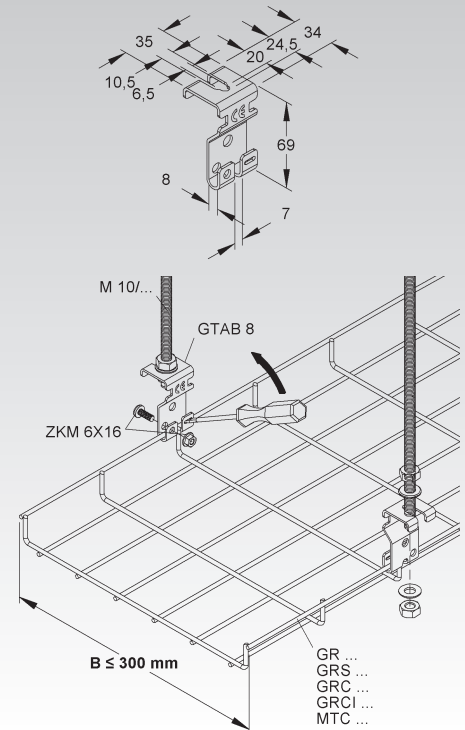

Hanger/Wall Bracket for Wire Mesh Tray

model no.	height H	length A	admissible load F at L/2	Weight per 100 pcs	Pack/Box Qty
	mm Inch	mm Inch	kN	kg	
S GTTKS 150 S	120 4,7	215 8,5	1,08	38	20
S GTTKS 200 S	120 4,7	265 10,4	0,86	43	20
S GTTKS 300 S	120 4,7	365 14,4	0,64	60	20
E4 GTTKS 150 E4	120 4,7	215 8,5	1,08	38	20
E4 GTTKS 200 E4	120 4,7	265 10,4	0,86	40	20

Specifically designed for boltless attachment of wire mesh tray.
The load rating shown is valid only for proper anchorage to the building structure.

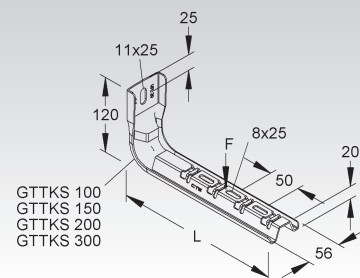

Hanger for Wire Mesh Tray

model no.	height H	length A	Weight per 100 pcs	Pack/Box Qty
	mm Inch	mm Inch	kg	
S GTTKS 400 S	170 6,7	465 18,3	71	20
S GTTKS 500 S	170 6,7	565 22,2	86	20
S GTTKS 600 S	170 6,7	665 26,2	95	20

Specifically designed for boltless attachment of wire mesh tray.

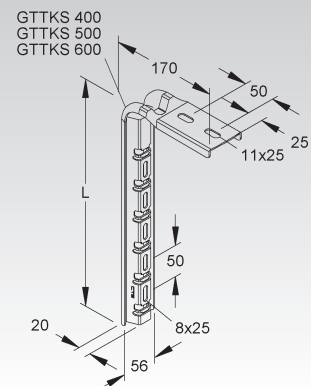

WIRE MESH TRAY SYSTEM ACCESSOIRES

Wall/Ceiling Bracket for Wire Mesh Tray

model no.		height H	length A	admissible load F at L/2 kN	Weight per 100 kg	Pack/ Box Qty
		mm Inch	mm Inch			
S	GTTKSU 100 S	183 7,2	165 6,5	1,22	53	1
S	GTTKSU 150 S	183 7,2	215 8,5	1,00	60	1
S	GTTKSU 200 S	183 7,2	265 10,4	0,81	67	1

The load rating shown is only valid for proper anchorage to the building structure.

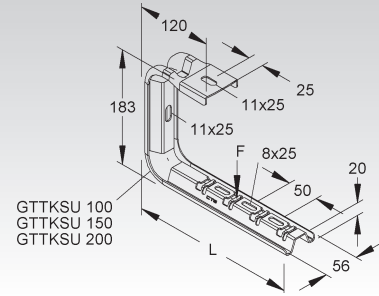

Wall/Ceiling Bracket for Wire Mesh Tray

model no.		height H	length A	admissible load F at L/2 kN	Weight per 100 kg	Pack/ Box Qty
		mm Inch	mm Inch			
S	GTTKSU 300 S	183 7,2	365 14,4	0,64	85	1

The load rating shown is only valid for proper anchorage to the building structure.

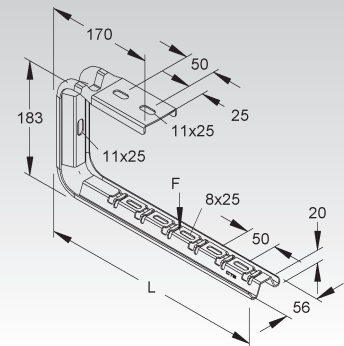

C-Bracket for Mesh Tray

model no.		admissible load F at L/2 kN	Weight per 100 kg	Pack/ Box Qty
★ S	GTCB 50/100 S	0,2	20	25
★ F	GTCB 50/100 F	0,2	20	25
★ E3	GTCB 50/100 E3	0,2	20	25

Suitable for: MTC tray in 50 and 100 mm width only

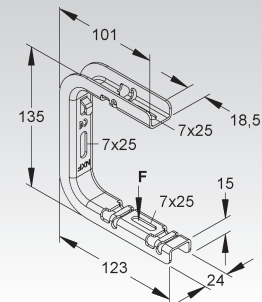

Center Hanger/Trapeze Support for Wire Mesh Basket

model no.		length A	Weight per 100 pcs/m kg	Pack/ Box Qty
		mm Inch		
S	GTTW 300 S	350 13,8	39	1
S	GTTW 500 S	550 21,7	90	1
S	GTTW 600 S	650 25,6	75	1
S	GTTW 3 S	3000 118,1	358	3 m
F	GTTW 3 F	3000 118,1	358	3 m
E4	GTTW 2 E4	2000 78,7	239	2 m

Specifically designed for boltless attachment of wire mesh tray.
Lock wire mesh tray with a screwdriver.



GTTW 500 S

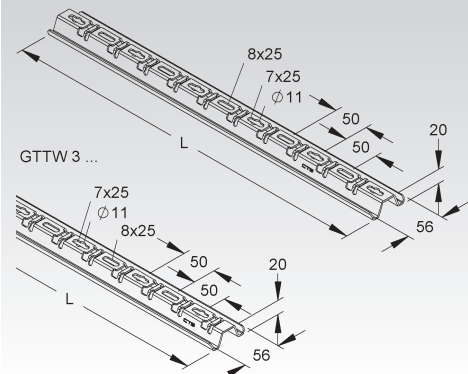

Pedestal Clamp

model no.	height H		width B		length A		thick- ness t mm	Weight per 100 kg	Pack/ Box Qty
	mm	Inch	mm	Inch	mm	Inch			
★ S DBSK 30.30/195-1.5 S	30	1,2	30	1,2	195	7,7	1,5	17,37	1

U-Bolts on request.

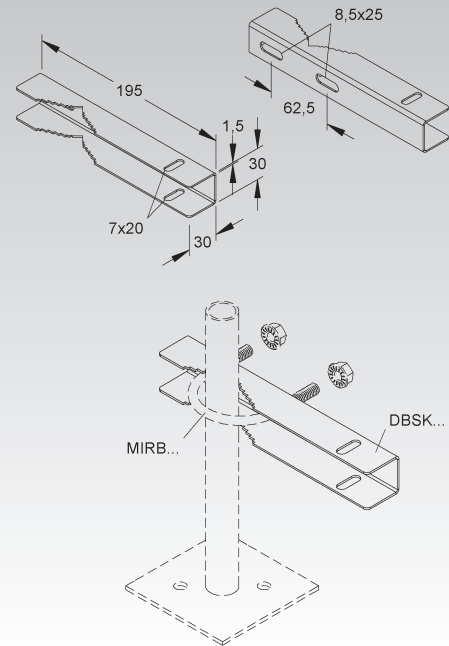

Floor Stand

model no.	height H		width B		width B1		Weight per 100 kg	Pack/ Box Qty
	mm	Inch	mm	Inch	mm	Inch		
★ V GRBS 42.100 V	42	1,7	95	3,7	171	6,7	17,84	1
★ V GRBS 42.200 V	42	1,7	195	7,7	271	10,7	25,74	1
★ V GRBS 42.300 V	42	1,7	295	11,6	371	14,6	33,63	1
★ V GRBS 42.400 V	42	1,7	395	15,6	471	18,5	41,52	1
★ V GRBS 42.500 V	42	1,7	495	19,5	571	22,5	52,51	1
★ V GRBS 42.600 V	42	1,7	595	23,4	671	26,4	60,40	1

Please use GTL 30... square washers in combination with FLM 6x20... bolts to install walkable tray on GRBS... floorstands.

GRBS 42.100 - 400

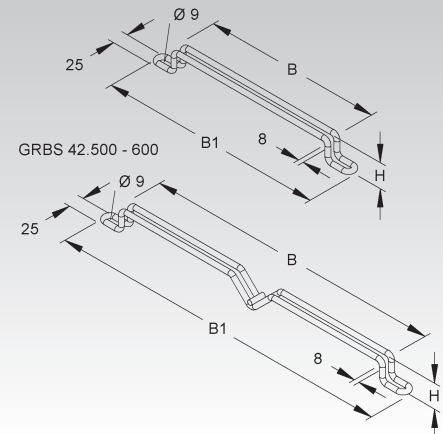

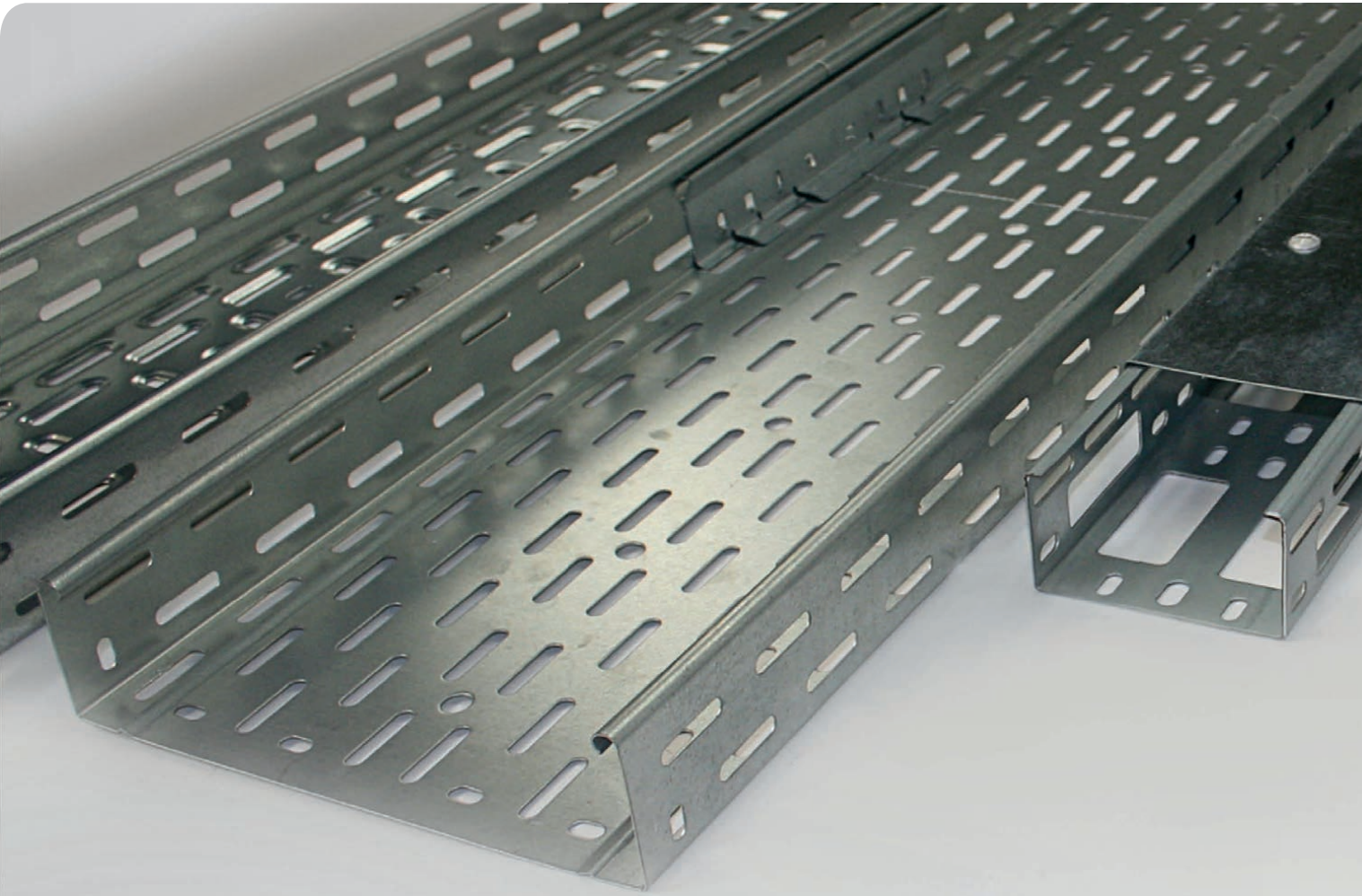

CABLE TRAY SYSTEM

- Cable Tray
- Barrier Strips
- Fittings
- Accessoires
- Covers



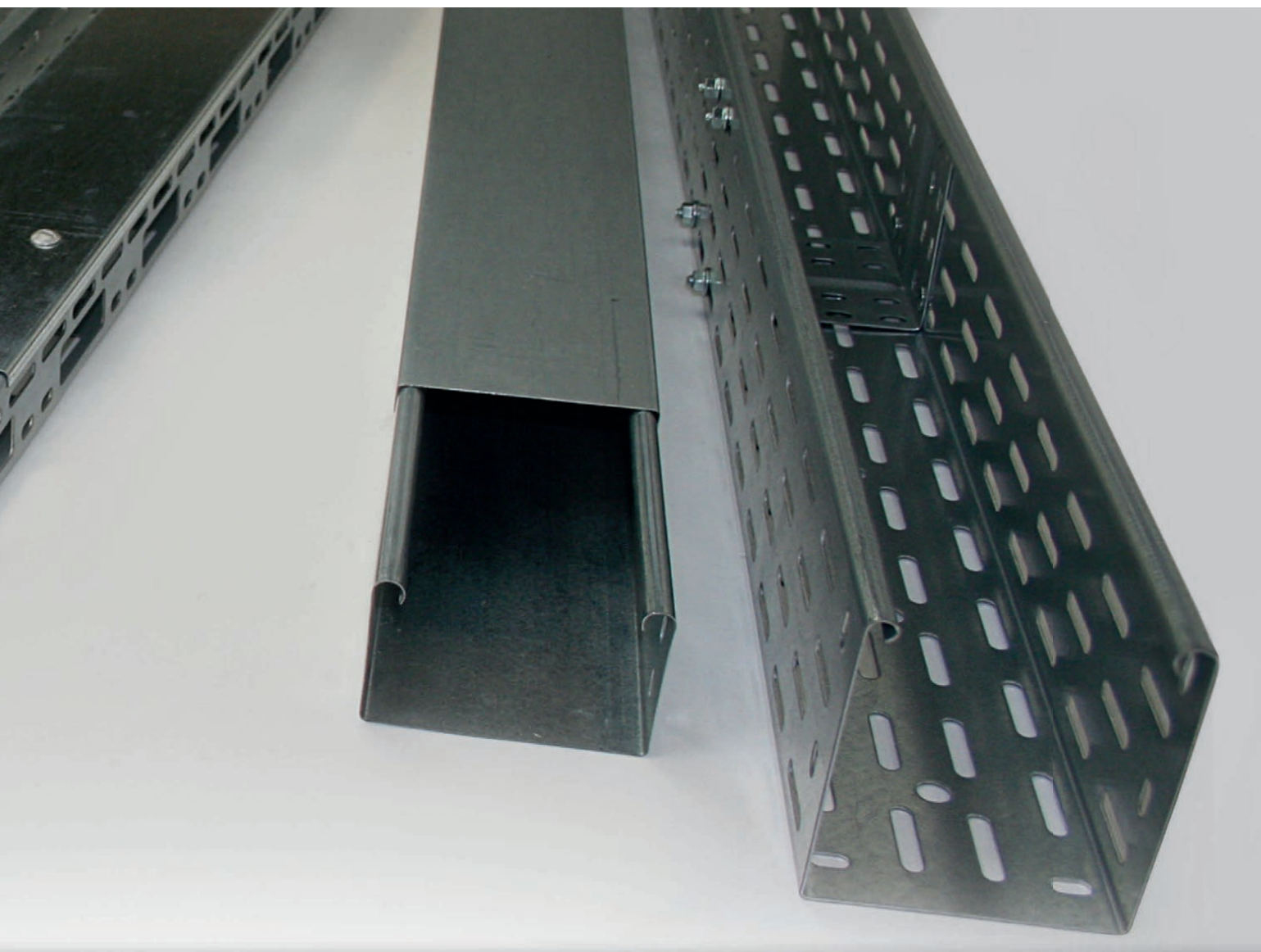

The Niedax Cable Tray is an extremely versatile and cost effective solution for your cabling needs. You can select from a wide range of tray sizes, fittings and accessories in various material thicknesses and finishes. Niedax Cable Tray is adaptable to your special needs, customized dimensions are available upon request

CABLE TRAY SYSTEM

Available Side Rail Heights

SYSTEM	Mini Cable Tray	RL...	Page 167
	Distribution Cable Tray	RSV...	Page 168
ZUBEHÖR	Edge Protection Ring	KSR...	Page 169
	Cover for Mini Cable Tray	RD 50	Page 167
	Cover for Mini Cable Tray	RDV 50	Page 167
	Cover for Distribution Cable Tray	RDSV...	Page 169
	Turnbolt Lock	RDRS...	Page 169
	Universal Splice Plate	RVV 50...	Page 169
	Extension Horizontal Tee	RTAK...	Page 170
	Cover for Horizontal Extension Tee	RTAKDV...	Page 170
	Horizontal Elbow 90°	RESK...	Page 170
	Cover for 90° Horizontal Elbow	RESKDV...	Page 170
	Horizontal Tee	RTSK...	Page 170
	Cover for Horizontal Tee	RTSKDV...	Page 171

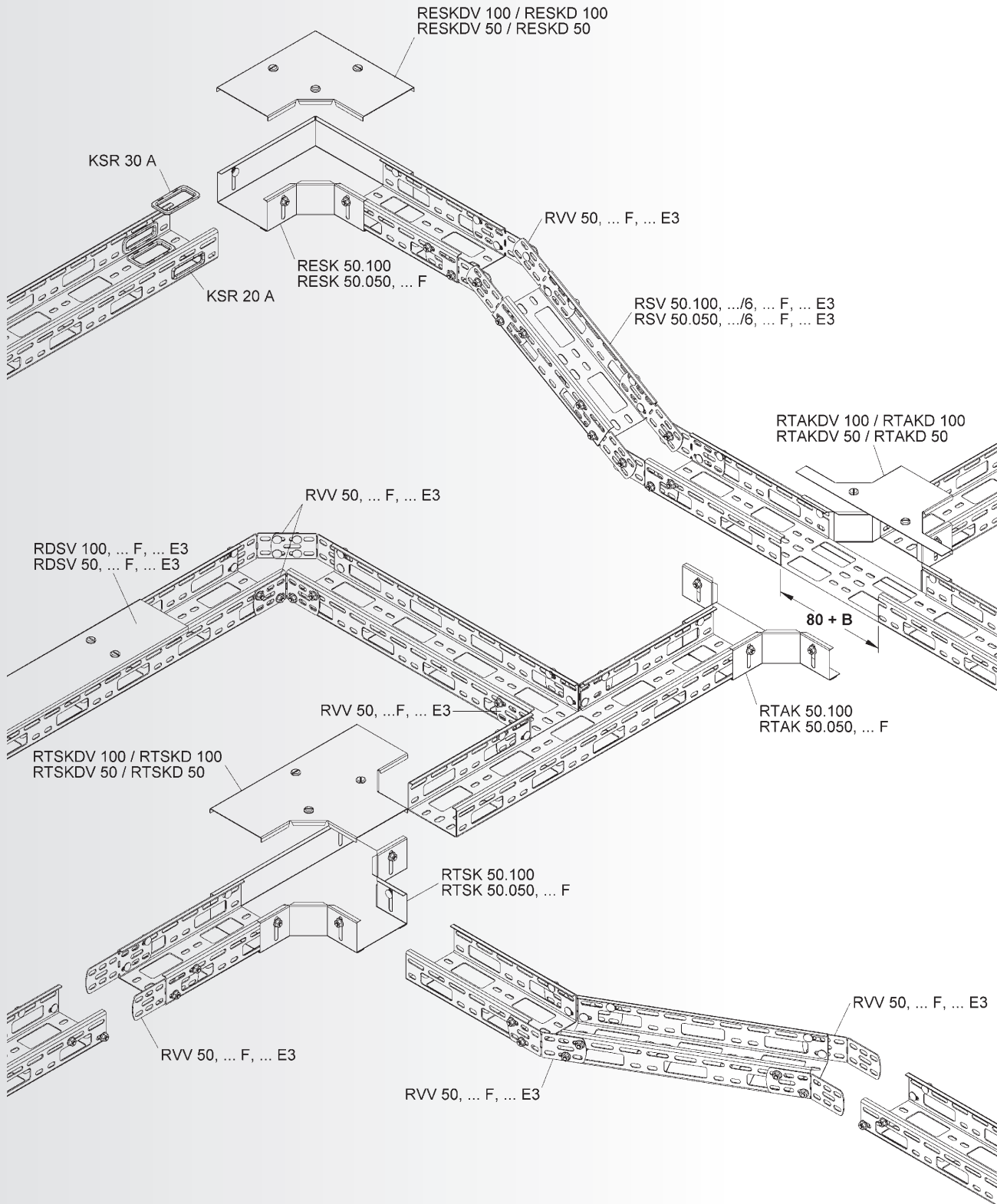

One-Piece Cable Tray Specifications:

➔ A. CABLE TRAY DESIGN

1. Cable Tray shall be made of straight sections, fittings and accessories as defined in the latest NEMA standards per NEMA VE-1. Standard cable trays shall be UL classified as equipment grounding conductors.

➔ B. MATERIAL

1. **Pre-galvanized steel.** The structural quality of the steel shall meet the minimum yield and tensile strength of the ASTM standards (ASTM A 653) with G 90 coating thickness. All cable trays to be labeled for material identification purposes.
2. **Hot dipped galvanized steel.** All trays to be hot-dipped galvanized in accordance with ASTM A123. All trays to be labeled for material identification.
3. **Stainless steel.** All trays are to be constructed of AISI type 304 or type 316 stainless steel. All trays to be labeled for material identification.

➔ C. TRAY TYPES

1. **Ventilated cable tray.** Trays are to be fabricated from continuous roll-formed structural quality steel. Tray shall be ventilated on both the bottom of the tray and on the sides for maximum ventilation of the cables.
2. **Solid cable tray.** Trays are to be fabricated from continuous roll-formed structural quality steel. Sides are to be solid as well as bottom for maximum cable enclosure and support.
3. **Distribution cable tray.** Trays are to be fabricated from continuous roll-formed structural quality steel. Tray shall be ventilated on sides and bottom and will also contain larger openings on both bottom and side for cables to exit and enter the cable tray. Openings shall be insulated with plastic edge protection rings that are purchased separately for cable protection where needed.

➔ D. TRAY SIZE

1. **Height:** Trays shall have an overall height of 1.4", 2", 2.3", 3.3", and 4.3" (35, 50, 60, 85 and 110 mm). Loading depth is the same as the overall height, as there are no rungs to reduce the fill of the tray.
2. **Width:** Widths shall be 2", 4", 6", 8", 12", 16", 20" and 24" (50, 100, 150, 200, 300, 400, 500 and 600 mm).
3. **Length:** Length shall be a nominal 10' or 3 meters.

➔ E. ACCESSORIES

1. **Covers.** Covers shall be supplied as an option to protect tray cable where needed. Covers will be solid and have the option of containing three pair of turn-bolt locks to secure the covers to the lips of the cable tray. Covers can also be plain, and locks can be installed separately.
2. **Splice plates.** Splice plates shall be supplied with the straight sections of the tray and are installed with four sets of nuts/bolts that are also supplied. Splice plates fit internally to the tray and are one-piece U shaped to fit into both adjoining pieces of cable tray.
3. **Other accessories** shall be furnished as required to protect, support, and install a cable tray system. Fittings shall made of the same material as the cable tray whenever possible. Fittings can be of factory construction or may also be of a type that allows field constructed fittings.

➔ F. LOADING CAPABILITIES

1. Cable tray shall meet the load/span class designation in accordance with NEMA VE 1 and CSA E22.2 No 126.1. Cable tray shall also meet load/span designation in accordance with IEC 61537.

➔ G. DESIGN AND MANUFACTURE

1. Cable tray design shall be manufactured by The Niedax Group, series RLCX/RLCPVX/RLX/RLVX/RLUX, RSX/RSUX/RSVX series.



Mini Cable Tray

ventilated, with return flange

	model no.	height H		width B		thickness t	length A	Weight per 100 m kg	Pack/Box Qty
		mm	Inch	mm	Inch				
S	RL 50.050	50	2	50	2	0,75	3000 118,1	96,85	2 x 3 m
S	RL 50.050/6	50	2	50	2	0,75	6000 236,2	94,94	2 x 6 m

perforation allows easy mounting of splice plates and fittings

Centered punchholes allow hanging with M12 (1/2") threaded rod.

One RV... splice plate included with every piece of cable tray.

Also available as solid (non ventilated) tray: RLU 50.050

Load Chart: q = uniformly distributed load (tested according to DIN EN IEC 61537 standard)

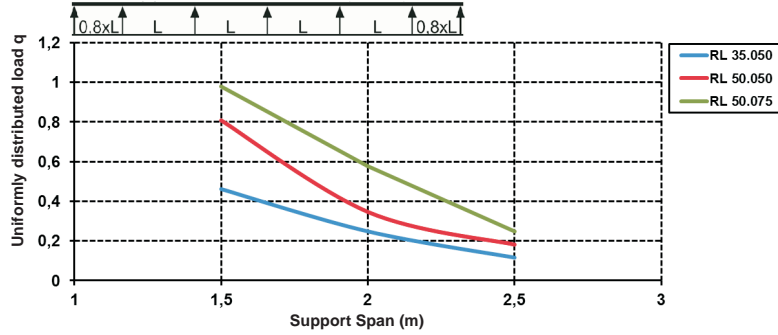

Height 50 mm
Nominal 2 inches

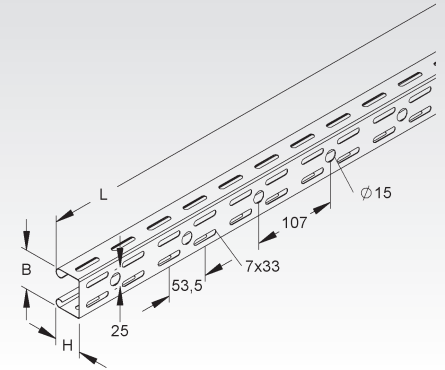
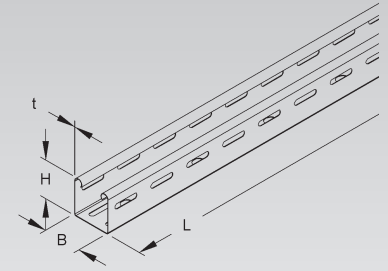

Cover for Mini Cable Tray

	model no.	inside dimension (B)		Weight per 100 m kg	Pack/Box Qty
		mm	Inch		
S	RD 50	50	2	43,5	2 x 3 m

Suitable for: RL... and RLU 50... tray

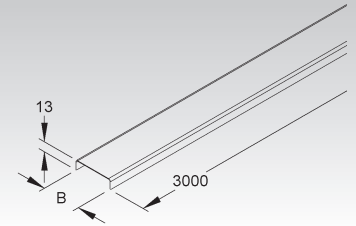

Cover for Mini Cable Tray

with turnbolt locks

	model no.	inside dimension (B)		Weight per 100 m kg	Pack/Box Qty
		mm	Inch		
S	RDV 50	50	2	44,2	2 x 3 m

Suitable for: RL... and RLU 50... tray

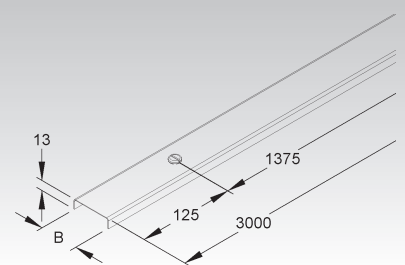

CABLE TRAY SYSTEM

Distribution Cable Tray

ventilated, with return flange

model no.	height H	width B	thick- ness t	length A		Weight per 100 m kg	Pack/ Box Qty
				mm Inch	mm Inch		
S RSV 50.050	50 2	50 2	1,5	3000 118,1	126,10	2 x 3 m	
S RSV 50.050/6	50 2	50 2	1,5	6000 236,2	126,10	2 x 6 m	
F RSV 50.050 F	50 2	50 2	1,5	3000 118,1	138,71	2 x 3 m	
E3 RSV 50.050 E3	50 2	50 2	1,5	3000 118,1	126,90	2 x 3 m	

bottom and side plates perforated with staggered punch holes
square punch holes of 30x65 mm (bottom) and of 20x65 mm (side rail) are provided for cable or pipe dropouts

Splice plates are not included. Please order two RVV 50 per joint.

Load Chart: q = uniformly distributed load (tested according to DIN EN IEC 61537 standard)

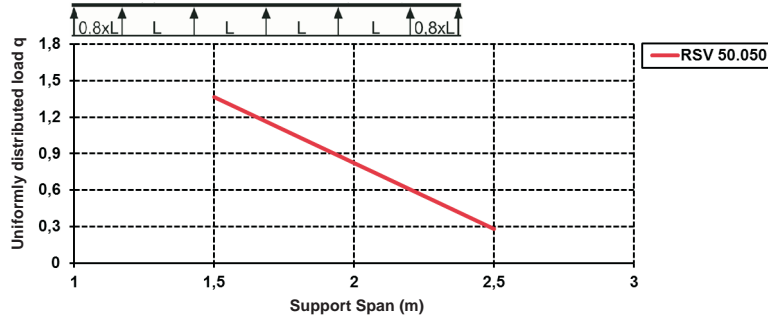

Height 50 mm
Nominal 2 inches

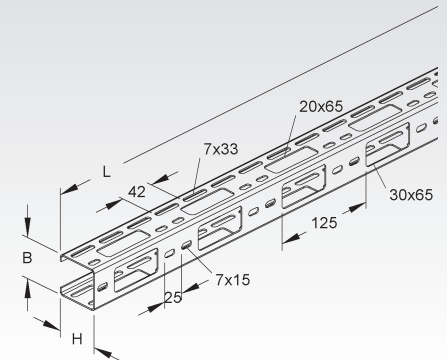
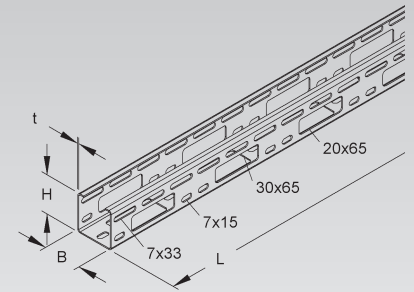

Distribution Cable Tray

ventilated, with return flange

model no.	height H	width B	thick- ness t	length A		Weight per 100 m kg	Pack/ Box Qty
				mm Inch	mm Inch		
S RSV 50.100	50 2	100 3,9	1,5	3000 118,1	162,20	2 x 3 m	
S RSV 50.100/6	50 2	100 3,9	1,5	6000 236,2	162,23	2 x 6 m	
F RSV 50.100 F	50 2	100 3,9	1,5	3000 118,1	178,45	2 x 3 m	
E3 RSV 50.100 E3	50 2	100 3,9	1,5	3000 118,1	163,30	2 x 3 m	

bottom and side plates perforated with staggered punch holes
square punch holes of 30x65 mm (bottom) and of 20x65 mm (side rail) are provided for cable or pipe dropouts

Splice plates are not included. Please order two RVV 50 per joint.

Load Chart: q = uniformly distributed load (tested according to DIN EN IEC 61537 standard)

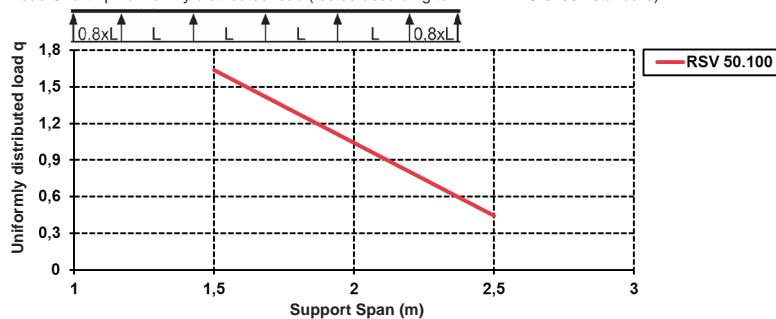

Height 50 mm
Nominal 2 inches

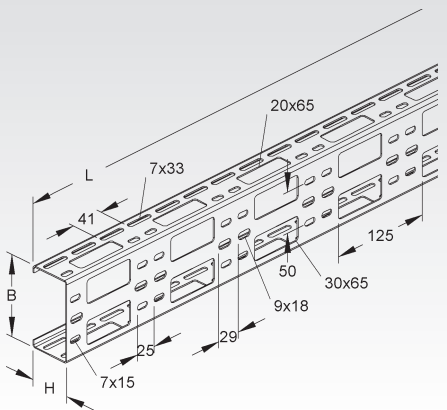
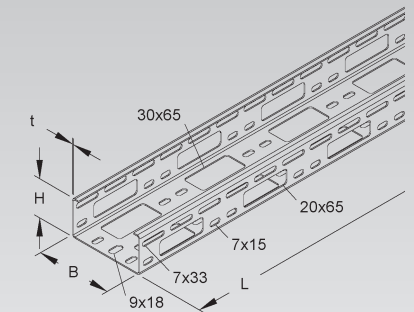

Edge Protection Ring

UV resistant

model no.	color	inside height H		inside dimension (B)		Weight per 100 pcs kg	Pack/Box Qty	
		mm	Inch	mm	Inch			
K04	KSR 20 A	black	14,5	0,6	58	2,3	0,32	20
K04	KSR 30 A	black	24,0	0,9	58	2,3	0,38	20

to protect cables at the knockouts of tray or surface metal raceways

Suitable for: RSV 50... distribution cable tray

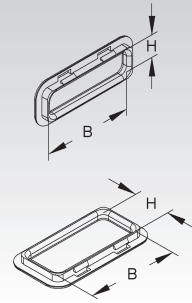

Cover for Distribution Cable Tray

with turnbolt locks

model no.	inside dimension (B)	Weight per 100 m kg	Pack/Box Qty		
				mm	Inch
S	RDSV 50	50	2	38,6	2 x 3 m
S	RDSV 100	100	3,9	68,3	2 x 3 m
F	RDSV 50 F	50	2	42,8	2 x 3 m
F	RDSV 100 F	100	3,9	75,9	2 x 3 m
E3	RDSV 50 E3	50	2	40,4	2 x 3 m
E3	RDSV 100 E3	100	3,9	74,0	2 x 3 m

Suitable for: distribution cable tray RSV 50... and RSV 100...

Please use turnbolt lock RDRS 2 for RDSV 100 covers and RDRS 2/50 for RDSV 50 covers.

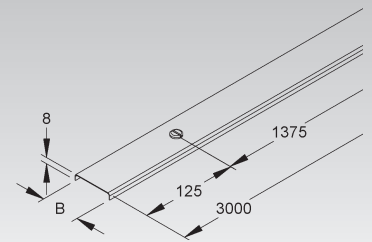

Turnbolt Lock

locking nut included

model no.	Weight per 100 pcs kg	Pack/Box Qty	
S	RDRS 2	1,3	100
E3	RDRS 2 E3	1,5	100

Suitable for: all R-series fitting covers and RSV 50.100 distribution tray covers

Not sufficient for securing covers to tray installed vertically or sideways nor for securing covers against windloads. Please use self tapping screws, steel cable ties or cover-hinges in addition.

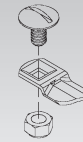

Turnbolt Lock

locking nut included

model no.	Weight per 100 pcs kg	Pack/Box Qty	
S	RDRS 2/50	1,3	100
E3	RDRS 2/50 E3	1,5	100

Suitable for: RSV 50.050 distribution tray covers

distribution cable tray covers and fittings in 50 mm width

Not sufficient for securing covers to tray installed vertically or sideways nor for securing covers against windloads. Please use self tapping screws, steel cable ties or cover-hinges in addition.

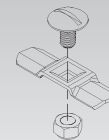

Universal Splice Plate

model no.	height H		width B		Weight per 100 pcs kg	Pack/Box Qty	
	mm	Inch	mm	Inch			
S	RVV 50	44	1,7	135	5,3	8,70	20
F	RVV 50 F	44	1,7	135	5,3	9,75	20
E3	RVV 50 E3	44	1,7	135	5,3	8,77	20

2 pieces required per joint

Universal splice plate for straight and angled joints.

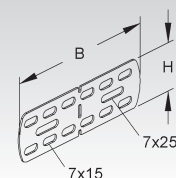

CABLE TRAY SYSTEM

Extension Horizontal Tee

	model no.	height H		inside dimension (B)		Weight per 100 pcs kg	Pack/Box Qty
		mm	Inch	mm	Inch		
S	RTAK 50.050	50	2	52	2	25,02	1
S	RTAK 50.100	50	2	102	4	29,73	1
F	RTAK 50.050 F	50	2	52	2	27,36	1

Suitable for: mini cable tray RL 50.050 and distribution cable trays RSV 50...

Height 50 mm
Nominal 2 inches

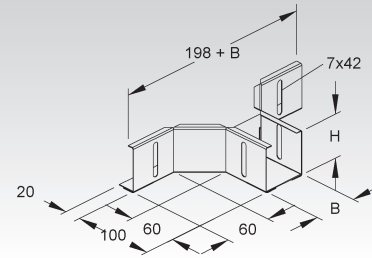

Cover for Horizontal Extension Tee

with turnbolt locks

	model no.	inside dimension (B)		Weight per 100 pcs kg	Pack/Box Qty
		mm	Inch		
S	RTAKDV 50	54	2,1	13,2	1
S	RTAKDV 100	104	4,1	17,0	1

Suitable for: RTAK... horizontal extension tee
Hot-dip galvanized finish available on request.

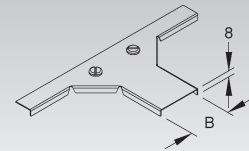

Horizontal Elbow 90°

	model no.	height H		inside dimension (B)		Weight per 100 pcs kg	Pack/Box Qty
		mm	Inch	mm	Inch		
S	RESK 50.050	50	2	52	2	32,23	1
S	RESK 50.100	50	2	102	4	50,45	1
F	RESK 50.050 F	50	2	52	2	35,03	1

Suitable for: mini cable tray RL 50.050 and distribution cable trays RSV 50...

Height 50 mm
Nominal 2 inches

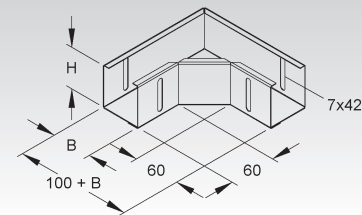

Cover for 90° Horizontal Elbow

with turnbolt locks

	model no.	inside dimension (B)		Weight per 100 pcs kg	Pack/Box Qty
		mm	Inch		
S	RESKDV 50	54	2,1	16,8	1
S	RESKDV 100	104	4,1	32,0	1

Suitable for: RESK... horizontal 90° elbow
Hot-dip galvanized finish available on request.

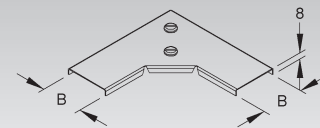

Horizontal Tee

	model no.	height H		inside dimension (B)		Weight per 100 pcs kg	Pack/Box Qty
		mm	Inch	mm	Inch		
S	RTSK 50.050	50	2	52	2	43,74	1
S	RTSK 50.100	50	2	102	4	63,62	1
F	RTSK 50.050 F	50	2	52	2	110,00	1

Suitable for: mini cable tray RL 50.050 and distribution cable trays RSV 50...

Height 50 mm
Nominal 2 inches

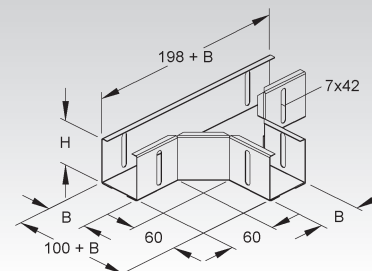

Cover for Horizontal Tee

with turnbolt locks

	model no.	inside dimension (B) mm Inch	Weight per 100 pcs kg	Pack/Box Qty
S	RTSKDV 50	54 2,1	20,37	1
S	RTSKDV 100	104 4,1	39,04	1

Suitable for: RTSK... horizontal tee

Hot-dip galvanized finish available on request.

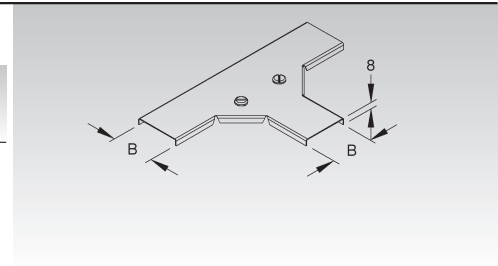

CABLE TRAY SYSTEM

Available Side Rail Heights



SYSTEM			
	Cable Tray	RLVC...	Page 175
	★ Distribution Cable Tray	RLCI...	Page 176
	Cable Tray	RL...	Page 177
	Cable Tray	RLU...	Page 177
	Heavy Duty Cable Tray	RS...	Page 178
	Heavy Duty Cable Tray	RSU...	Page 178
ZUBEHÖR	Boltless splice plate	RVC 60	Page 176
	Edge Protection Ring	KSR 30 A	Page 176
	U-shaped Splice Plate	RV...	Page 179
	Universal Splice Plate	RVV 50...	Page 179
	★ Universal Splice Plate	RSUV 60-1.5/200 S	Page 179
	Barrier Strip	RW...	Page 179
	Splice Plate for Barrier Strip	RTV...	Page 180
	Mounting Plate for Barrier Strip	RTPH 50+M6	Page 180
	Extension Horizontal Tee	RTA...	Page 181
	Horizontal Elbow Building Block	REK...	Page 181
	Flexible Horizontal Elbow 0-90°	RBAV...	Page 181
	Horizontal Elbow 45°	RBA...	Page 182
	Horizontal Elbow 90°	RES...	Page 182
	Horizontal Tee	RTS...	Page 182
	Horizontal Cross	RKS...	Page 183
	Reducer/Blind End	RA...	Page 183
	Adjustable Horizontal Splice/Reducer/Blind End	RAW...	Page 183
	Adjustable Vertical Splice Plate	RGV...	Page 183
	Splice/Link Kit	RGE...	Page 184
	Vertical Inside Elbow 90°	RSD...	Page 184
	Vertical Outside Elbow 90°	RFD...	Page 184
	Vertical Tee Down, lengthwise	RTL...	Page 185
	Vertical Tee Down, crosswise	RTQ...	Page 185
	Edge Protection Plate	RKB...	Page 185

See covers for cable trays and fittings on page 212 and following.



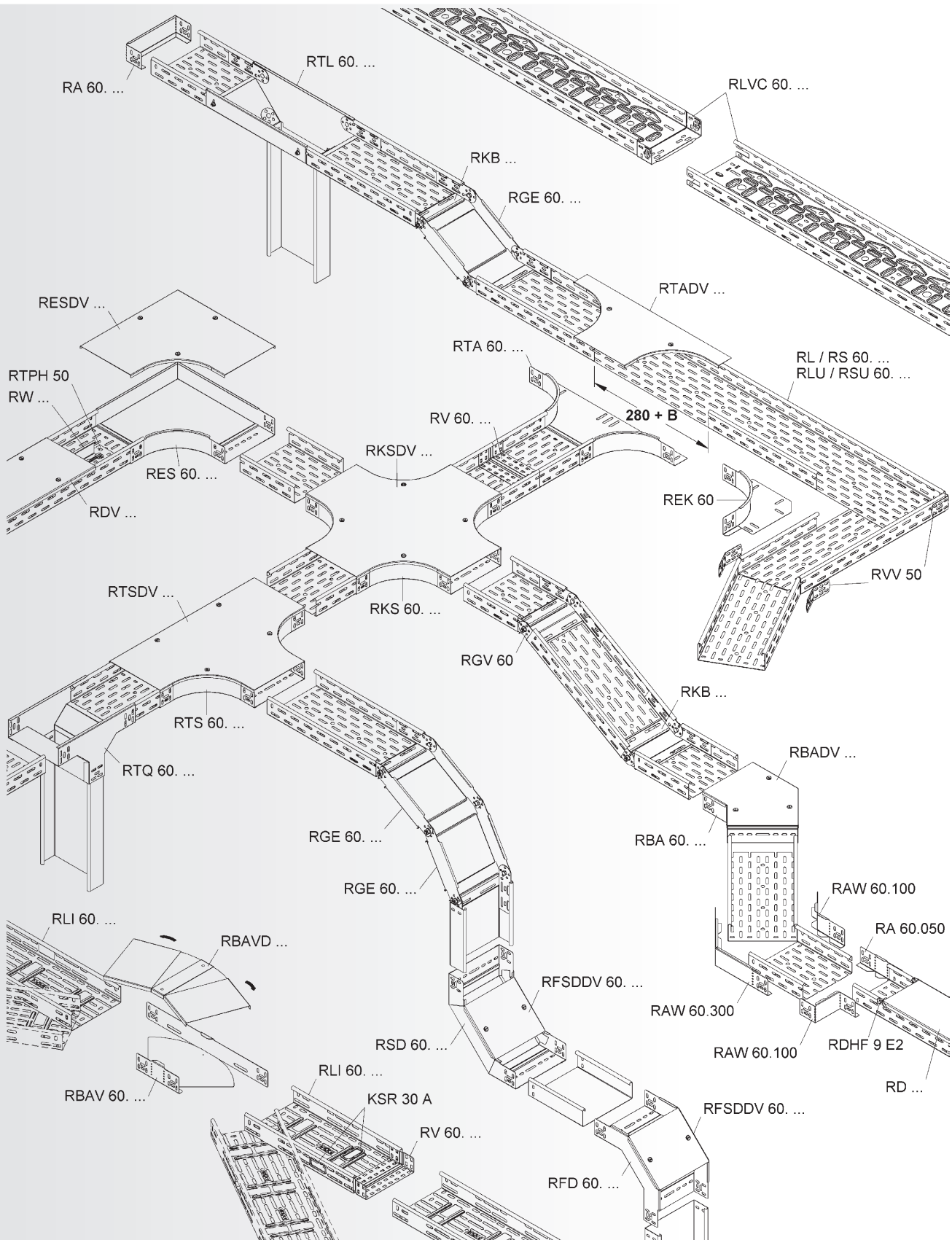

CABLE TRAY SYSTEM

➔ Load/Span Class Designation in accordance with NEMA VE 1 and CSA E22.2 No. 126.1

Niedax Series	Minimum Area		Load class in accordance to NEMA VE 1		
	(calculational) mm ² / in. ²	in accordance to NEMA VE 2 mm ² / in. ²	Rated Load Kg/m / lb./ft.	Support spacing m / ft.	Load/Span Class
RLVCX 60.100	133 / 0.21	129 / 0.2	53 / 35.8	2 / 6.6	-
RLVCX 60.200	207 / 0.32	129 / 0.2	53 / 35.8	2 / 6.6	-
RLVCX 60.300	222 / 0.34	129 / 0.2	53 / 35.8	2 / 6.6	-
RLVCX 60.400	284 / 0.44	258 / 0.4	105 / 70.9	2 / 6.6	A
RLVCX 60.500	313 / 0.48	258 / 0.4	105 / 70.9	2 / 6.6	A
RLVCX 60.600	403 / 0.62	258 / 0.4	80 / 54.1	2 / 6.6	A
RLVCX 60.600 E3	358 / 0.56	258 / 0.4	98 / 66.2	2 / 6.6	A
RLX 60.100, ... F	169 / 0.26	129 / 0.2	93 / 62.5	2 / 6.6	A
RLX 60.150, ... F	202 / 0.31	129 / 0.2	93 / 62.5	2 / 6.6	A
RLX 60.200, ... F	234 / 0.36	129 / 0.2	93 / 62.5	2 / 6.6	A
RLX 60.300, ... F	332 / 0.51	258 / 0.4	93 / 62.5	2 / 6.6	A
RLX 60.400, ... F	404 / 0.63	258 / 0.4	93 / 62.5	2 / 6.6	A
RLX 60.500, ... F	476 / 0.74	452 / 0.7	93 / 62.5	2 / 6.6	A
RLX 60.600, ... F	548 / 0.85	452 / 0.7	93 / 62.5	2 / 6.6	A
RLUX 60.100, ... F	220 / 0.34	129 / 0.2	93 / 62.5	2 / 6.6	A
RLUX 60.150, ... F	265 / 0.41	258 / 0.4	93 / 62.5	2 / 6.6	A
RLUX 60.200, ... F	310 / 0.48	258 / 0.4	93 / 62.5	2 / 6.6	A
RLUX 60.300, ... F	444 / 0.69	258 / 0.4	93 / 62.5	2 / 6.6	A
RLUX 60.400, ... F	544 / 0.84	452 / 0.7	93 / 62.5	2 / 6.6	A
RLUX 60.500, ... F	644 / 1.00	645 / 1.0	93 / 62.5	2 / 6.6	A
RLUX 60.600, ... F	744 / 1.15	645 / 1.0	93 / 62.5	2 / 6.6	A
RLUX 60.100 E3	195 / 0.30	129 / 0.2	93 / 62.5	2 / 6.6	A
RLUX 60.200 E3	275 / 0.43	258 / 0.4	93 / 62.5	2 / 6.6	A
RLUX 60.300 E3	355 / 0.55	258 / 0.4	93 / 62.5	2 / 6.6	A
RLUX 60.400 E3	435 / 0.67	258 / 0.4	93 / 62.5	2 / 6.6	A
RLUX 60.500 E3	580 / 0.90	452 / 0.7	93 / 62.5	2 / 6.6	A
RLUX 60.600 E3	670 / 1.04	645 / 1.0	93 / 62.5	2 / 6.6	A
RSX 60.100, ... F	278 / 0.43	258 / 0.4	173 / 116.3	2 / 6.6	8A, C
RSX 60.200, ... F	386 / 0.60	258 / 0.4	173 / 116.3	2 / 6.6	8A, C
RSX 60.300, ... F	494 / 0.77	452 / 0.7	173 / 116.3	2 / 6.6	8A, C
RSX 60.400, ... F	602 / 0.93	452 / 0.7	173 / 116.3	2 / 6.6	8A, C
RSX 60.500, ... F	710 / 1.10	645 / 1.0	173 / 116.3	2 / 6.6	8A, C
RSX 60.600, ... F	818 / 1.27	645 / 1.0	173 / 116.3	2 / 6.6	8A, C
RSUX 60.100, ... F	362 / 0.56	258 / 0.4	173 / 116.3	2 / 6.6	8A, C
RSUX 60.200, ... F	512 / 0.79	452 / 0.7	173 / 116.3	2 / 6.6	8A, C
RSUX 60.300, ... F	662 / 1.03	645 / 1.0	173 / 116.3	2 / 6.6	8A, C
RSUX 60.400, ... F	812 / 1.26	645 / 1.0	173 / 116.3	2 / 6.6	8A, C
RSUX 60.500, ... F	962 / 1.49	645 / 1.0	173 / 116.3	2 / 6.6	8A, C
RSUX 60.600, ... F	1112 / 1.72	968 / 1.5	173 / 116.3	2 / 6.6	8A, C



Cable Tray

ventilated, with integrated molded splice plate

model no.	height H		width B		thick-ness t	Weight per 100 kg	Pack/Box Qty
	mm	Inch	mm	Inch			
S RLVC 60.100	60	2,4	100	3,9	0,75	128,52	2 x 3 m
S RLVC 60.200	60	2,4	200	7,9	0,75	186,69	2 x 3 m
S RLVC 60.300	60	2,4	300	11,8	0,75	243,15	2 x 3 m
S RLVC 60.400	60	2,4	400	15,7	0,90	358,78	2 x 3 m
S RLVC 60.500	60	2,4	500	19,7	0,90	425,74	2 x 3 m
S RLVC 60.600	60	2,4	600	23,6	0,90	499,90	2 x 3 m
* F RLVC 60.100 F	60	2,4	100	3,9	0,75	141,37	2 x 3 m
* F RLVC 60.200 F	60	2,4	200	7,9	0,75	205,36	2 x 3 m
* F RLVC 60.300 F	60	2,4	300	11,8	0,75	267,47	2 x 3 m
* F RLVC 60.400 F	60	2,4	400	15,7	0,90	394,66	2 x 3 m
* F RLVC 60.500 F	60	2,4	500	19,7	0,90	468,32	2 x 3 m
* F RLVC 60.600 F	60	2,4	600	23,6	0,90	549,89	2 x 3 m
E3 RLVC 60.100 E3	60	2,4	100	3,9	0,80	138,30	2 x 3 m
E3 RLVC 60.200 E3	60	2,4	200	7,9	0,80	201,01	2 x 3 m
E3 RLVC 60.300 E3	60	2,4	300	11,8	0,80	261,85	2 x 3 m
E3 RLVC 60.400 E3	60	2,4	400	15,7	0,80	321,34	2 x 3 m
E3 RLVC 60.500 E3	60	2,4	500	19,7	0,80	381,24	2 x 3 m
E3 RLVC 60.600 E3	60	2,4	600	23,6	0,80	447,58	2 x 3 m
* E5 RLVC 60.100 E5	60	2,4	100	3,9	0,80	139,70	2 x 3 m
* E5 RLVC 60.200 E5	60	2,4	200	7,9	0,80	203,05	2 x 3 m
* E5 RLVC 60.300 E5	60	2,4	300	11,8	0,80	264,50	2 x 3 m
* E5 RLVC 60.400 E5	60	2,4	400	15,7	0,80	324,60	2 x 3 m

bottom plate and side rail perforated with staggered punch holes

Hole pattern may vary based on width of tray.

Load Chart: q = uniformly distributed load (tested according to DIN EN IEC 61537 standard)

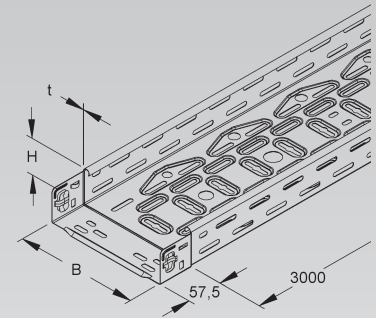
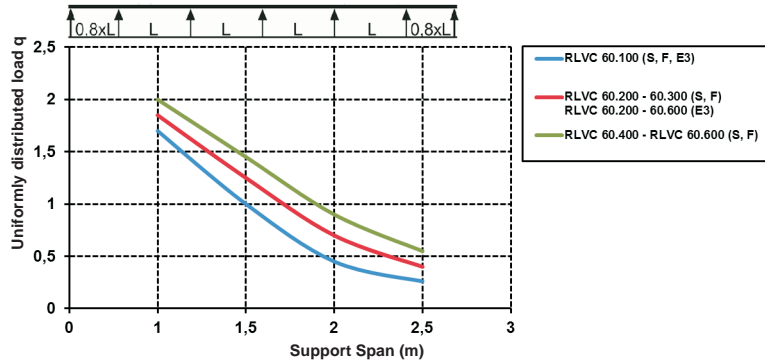

CABLE TRAY SYSTEM

Distribution Cable Tray

model no.	height H		width B		thickness t	Weight per 100 kg	Pack/Box Qty
	mm	Inch	mm	Inch			
S RLCI 60.100 S	60	2,4	100	3,9	0,9	140,56	2 x 3 m
S RLCI 60.200 S	60	2,4	200	7,9	0,9	195,54	2 x 3 m
S RLCI 60.300 S	60	2,4	300	11,8	1,0	272,34	2 x 3 m
S RLCI 60.400 S	60	2,4	400	15,7	1,0	323,95	2 x 3 m
S RLCI 60.500 S	60	2,4	500	19,7	1,0	375,60	2 x 3 m
S RLCI 60.600 S	60	2,4	600	23,6	1,0	427,26	2 x 3 m

designed for installation under sprinkler systems

Please order 2 RVC 60 splice plates for every piece of tray.

Load Chart: q = uniformly distributed load (tested according to DIN EN IEC 61537 standard)

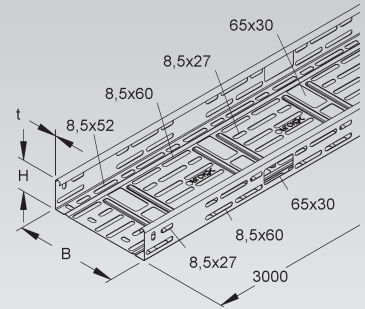
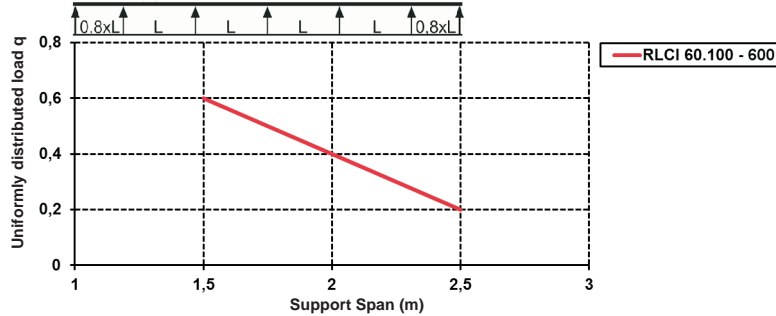

Boltless splice plate

model no.	height H	Weight per 100 pc. kg	Pack/Box Qty
	mm Inch		
S RVC 60	60 2,4	16,96	50

2 pieces required per joint

Suitable for: cable trays RLC 60..., RLuc 60... and RLCI 60...

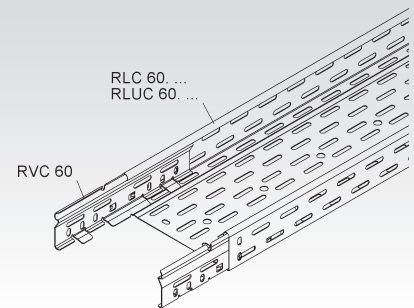
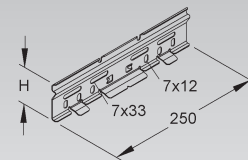

Edge Protection Ring

UV resistant

model no.	color	inside height H	inside dimension (B)	Weight per 100 pcs kg	Pack/Box Qty
		mm Inch	mm Inch		
K04 KSR 30 A	black	24 0,9	58 2,3	0,38	20

to protect cables at the knockouts of tray or surface metal raceways

Suitable for: RSV 50... and RLCI 60... distribution cable tray

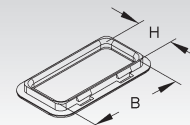

Cable Tray

ventilated

	model no.	height H		width B		thick-ness t	Weight per 100 m	Pack/Box Qty
		mm	Inch	mm	Inch			
S	RL 60.100	60	2,4	100	3,9	0,9	159,00	2 x 3 m
S	RL 60.150	60	2,4	150	5,9	0,9	185,32	2 x 3 m
S	RL 60.200	60	2,4	200	7,9	0,9	216,03	2 x 3 m
S	RL 60.300	60	2,4	300	11,8	1,0	306,06	2 x 3 m
S	RL 60.400	60	2,4	400	15,7	1,0	374,17	2 x 3 m
S	RL 60.500	60	2,4	500	19,7	1,0	450,00	2 x 3 m
S	RL 60.600	60	2,4	600	23,6	1,0	530,00	2 x 3 m
F	RL 60.100 F	60	2,4	100	3,9	0,9	170,04	2 x 3 m
F	RL 60.150 F	60	2,4	150	5,9	0,9	187,00	2 x 3 m
F	RL 60.200 F	60	2,4	200	7,9	0,9	237,08	2 x 3 m
F	RL 60.300 F	60	2,4	300	11,8	1,0	336,75	2 x 3 m
F	RL 60.400 F	60	2,4	400	15,7	1,0	372,39	2 x 3 m
F	RL 60.500 F	60	2,4	500	19,7	1,0	485,96	2 x 3 m
F	RL 60.600 F	60	2,4	600	23,6	1,0	560,20	2 x 3 m

Centered punchholes allow hanging with M10 (3/8") threaded rod.
Bottom plate and side rail perforated with staggered punch holes.

One RV... splice plate included with every piece of cable tray.

Load Chart: q = uniformly distributed load (tested according to DIN EN IEC 61537 standard)

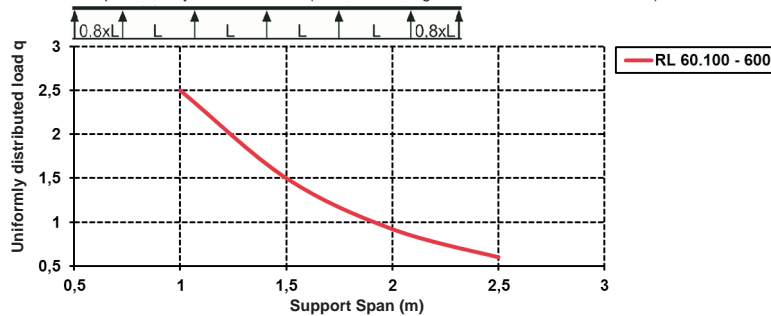

Height 60 mm
Nominal 2 3/8 inches

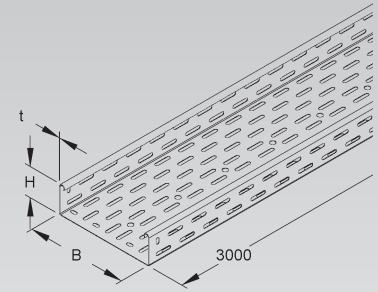
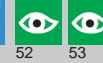

Cable Tray

solid, but with splice plate perforation

	model no.	height H		width B		thick-ness t	Weight per 100 m	Pack/Box Qty
		mm	Inch	mm	Inch			
S	RLU 60.100	60	2,4	100	3,9	0,9	178,40	2 x 3 m
S	RLU 60.150	60	2,4	150	5,9	0,9	214,75	2 x 3 m
S	RLU 60.200	60	2,4	200	7,9	0,9	251,10	2 x 3 m
S	RLU 60.300	60	2,4	300	11,8	1,0	358,60	2 x 3 m
S	RLU 60.400	60	2,4	400	15,7	1,0	439,63	2 x 3 m
S	RLU 60.500	60	2,4	500	19,7	1,0	520,18	2 x 3 m
S	RLU 60.600	60	2,4	600	23,6	1,0	600,73	2 x 3 m
F	RLU 60.100 F	60	2,4	100	3,9	0,9	196,37	2 x 3 m
F	RLU 60.200 F	60	2,4	200	7,9	0,9	276,38	2 x 3 m
F	RLU 60.300 F	60	2,4	300	11,8	1,0	394,68	2 x 3 m
F	RLU 60.400 F	60	2,4	400	15,7	1,0	483,87	2 x 3 m
F	RLU 60.500 F	60	2,4	500	19,7	1,0	572,52	2 x 3 m
F	RLU 60.600 F	60	2,4	600	23,6	1,0	661,16	2 x 3 m
E3	RLU 60.100 E3	60	2,4	100	3,9	0,8	159,00	2 x 3 m
E3	RLU 60.200 E3	60	2,4	200	7,9	0,8	215,00	2 x 3 m
E3	RLU 60.300 E3	60	2,4	300	11,8	0,8	292,00	2 x 3 m
E3	RLU 60.400 E3	60	2,4	400	15,7	0,8	352,00	2 x 3 m
E3	RLU 60.500 E3	60	2,4	500	19,7	0,9	472,00	2 x 3 m
E3	RLU 60.600 E3	60	2,4	600	23,6	0,9	539,00	2 x 3 m

One RV... splice plate included with every piece of cable tray.

Height 60 mm
Nominal 2 3/8 inches

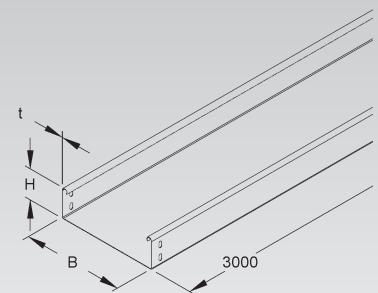

CABLE TRAY SYSTEM

Heavy Duty Cable Tray

ventilated

	model no.	height H		width B		thick-ness t mm	Weight per 100 m kg	Pack/Box Qty
		mm	Inch	mm	Inch			
S	RS 60.100	60	2,4	100	3,9	1,5	249,60	2 x 3 m
S	RS 60.200	60	2,4	200	7,9	1,5	349,94	2 x 3 m
S	RS 60.300	60	2,4	300	11,8	1,5	450,74	2 x 3 m
S	RS 60.400	60	2,4	400	15,7	1,5	551,56	2 x 3 m
S	RS 60.500	60	2,4	500	19,7	1,5	652,07	2 x 3 m
S	RS 60.600	60	2,4	600	23,6	1,5	787,00	2 x 3 m
F	RS 60.100 F	60	2,4	100	3,9	1,5	274,67	2 x 3 m
F	RS 60.200 F	60	2,4	200	7,9	1,5	384,99	2 x 3 m
F	RS 60.300 F	60	2,4	300	11,8	1,5	495,90	2 x 3 m
F	RS 60.400 F	60	2,4	400	15,7	1,5	606,82	2 x 3 m
F	RS 60.500 F	60	2,4	500	19,7	1,5	717,13	2 x 3 m
F	RS 60.600 F	60	2,4	600	23,6	1,5	827,45	2 x 3 m

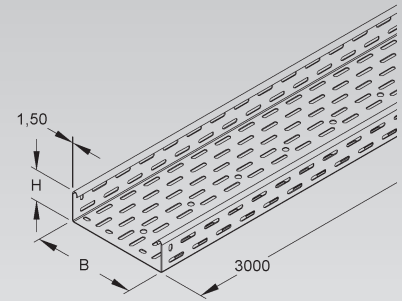
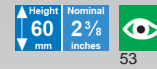

Bottom plate and side rail perforated with staggered punch holes. Centered punchholes allow hanging with M10 (3/8") threaded rod.

One RV... splice plate included with every piece of cable tray.

Load Chart: q = uniformly distributed load (tested according to DIN EN IEC 61537 standard)

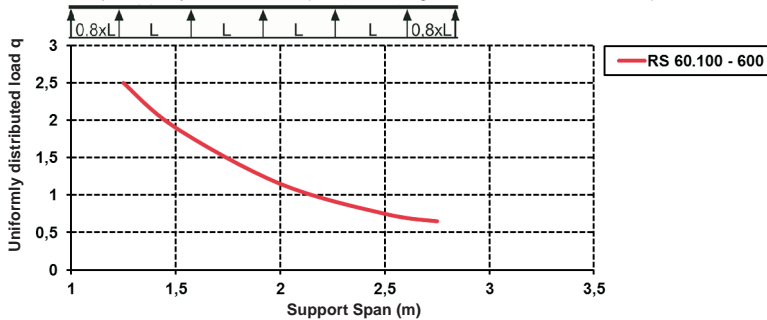

Heavy Duty Cable Tray

solid, but with splice plate perforation

	model no.	height H		width B		thick-ness t mm	Weight per 100 m kg	Pack/Box Qty
		mm	Inch	mm	Inch			
S	RSU 60.100	60	2,4	100	3,9	1,5	289,84	2 x 3 m
S	RSU 60.200	60	2,4	200	7,9	1,5	409,66	2 x 3 m
S	RSU 60.300	60	2,4	300	11,8	1,5	529,92	2 x 3 m
S	RSU 60.400	60	2,4	400	15,7	1,5	650,21	2 x 3 m
S	RSU 60.500	60	2,4	500	19,7	1,5	770,00	2 x 3 m
S	RSU 60.600	60	2,4	600	23,6	1,5	889,79	2 x 3 m
F	RSU 60.100 F	60	2,4	100	3,9	1,5	318,60	2 x 3 m
F	RSU 60.200 F	60	2,4	200	7,9	1,5	450,36	2 x 3 m
F	RSU 60.300 F	60	2,4	300	11,8	1,5	582,66	2 x 3 m
F	RSU 60.400 F	60	2,4	400	15,7	1,5	714,85	2 x 3 m
F	RSU 60.500 F	60	2,4	500	19,7	1,5	846,64	2 x 3 m
F	RSU 60.600 F	60	2,4	600	23,6	1,5	978,41	2 x 3 m

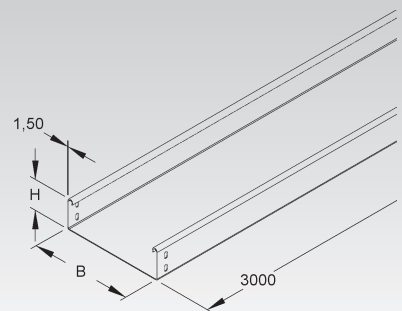

One RV... splice plate included with every piece of cable tray.



U-shaped Splice Plate

model no.	height H	width B		Weight per 100 pcs/pc. kg	Pack/ Box Qty
		mm Inch	mm Inch		
S RV 60.100	49 1,9	96 3,8	17,64	1	
S RV 60.150	49 1,9	146 5,7	20,71	1	
S RV 60.200	49 1,9	196 7,7	25,37	1	
S RV 60.300	49 1,9	296 11,7	31,51	1	
S RV 60.400	49 1,9	396 15,6	39,25	1	
S RV 60.500	49 1,9	496 19,5	45,38	1	
S RV 60.600	49 1,9	596 23,5	51,52	1	
F RV 60.100 F	49 1,9	96 3,8	19,56	1	
F RV 60.200 F	49 1,9	196 7,7	28,11	1	
F RV 60.300 F	49 1,9	296 11,7	34,86	1	
F RV 60.400 F	49 1,9	396 15,6	43,42	1	
F RV 60.500 F	49 1,9	496 19,5	50,16	1	
F RV 60.600 F	49 1,9	596 23,5	56,91	1	
E3 RV 60.100 E3	49 1,9	96 3,8	18,59	1	
E3 RV 60.200 E3	49 1,9	196 7,7	26,58	1	
E3 RV 60.300 E3	49 1,9	296 11,7	32,76	1	
E3 RV 60.400 E3	49 1,9	396 15,6	40,76	1	
E3 RV 60.500 E3	49 1,9	496 19,5	46,93	1	
E3 RV 60.600 E3	49 1,9	596 23,5	53,11	1	

Suitable for: RL/RS... cable trays

Height
60
mm

Nominal
2 3/8
inches

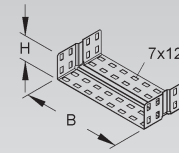

Universal Splice Plate

model no.	height H	width B		Weight per 100 pcs kg	Pack/ Box Qty
		mm Inch	mm Inch		
S RVV 50	44 1,7	135 5,3	8,70	20	
F RVV 50 F	44 1,7	135 5,3	9,75	20	
E3 RVV 50 E3	44 1,7	135 5,3	8,77	20	
E5 RVV 50 E5	44 1,7	135 5,3	8,86	20	

2 pieces required per joint

Universal splice plate for straight and angled joints.

Height
50
mm

Nominal
2
inches

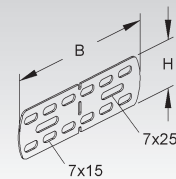

Universal Splice Plate

model no.	height H	width B		thick- ness t	Weight per 100 kg	Pack/ Box Qty
		mm Inch	mm Inch			
★ S RSUV 60-1.5/200 S	60 2,4	200 7,9	1,5	13,44	50	

for straight and angled joints

Height
60
mm

Nominal
2 3/8
inches

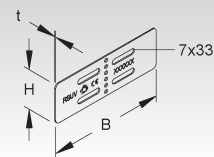

Barrier Strip

model no.	height H	thick- ness t	Weight per 100 m kg	Pack/ Box Qty
S RW 50	47 1,9	0,75	45,05	10 x 3 m
S RW 60	55 2,2	0,75	49,86	10 x 3 m
F RW 60 F	55 2,2	0,75	54,87	10 x 3 m
E3 RW 50 E3	47 1,9	0,80	48,32	10 x 3 m
E3 RW 60 E3	55 2,2	0,80	53,48	10 x 3 m

to separate wires and cables of different voltage levels or with different functions

Height
50
mm

Nominal
2
inches

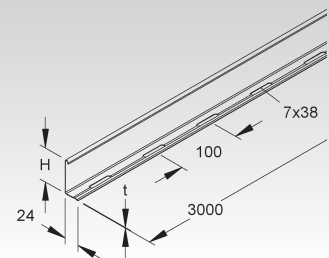

CABLE TRAY SYSTEM

Splice Plate for Barrier Strip

model no.	height H	length A		Weight per 100 pcs kg	Pack/ Box Qty
		mm Inch	mm Inch		
E2 RTV 50 E2	46,5 1,8	80 3,1	1,18	20	
E2 RTV 60 E2	54,5 2,1	80 3,1	1,39	20	

for positive locking connections and proper bonding of barrier strips

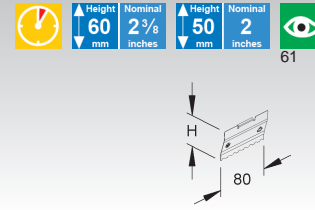

Mounting Plate for Barrier Strip

model no.	length A		width B	thick- ness t mm	Weight per 100 pcs kg	Pack/ Box Qty
	mm Inch	mm Inch				
S RTPH 50	83 3,3	59 2,3	0,9	3,36	20	

Mounting plate with latching mechanism for fast installation of barrier strips in ventilated RL/RS series cable trays.

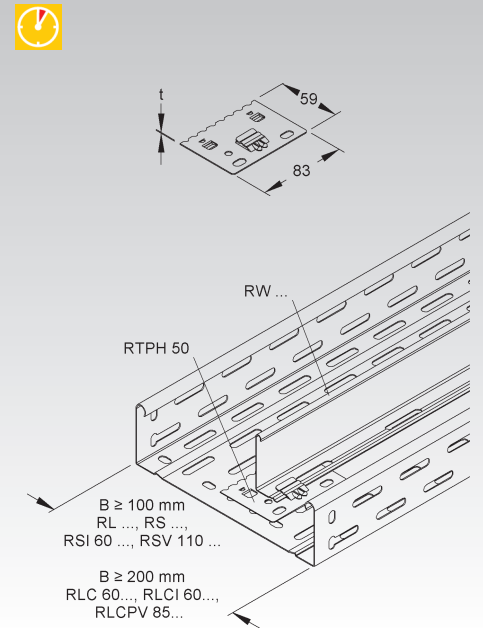

Mounting Plate for Barrier Strip with M6 Stud

model no.	length A		width B	thick- ness t mm	Weight per 100 pcs kg	Pack/ Box Qty
	mm Inch	mm Inch				
S RTPH 50 M6	83 3,3	59 2,3	0,9	3,98	50	

Mounting plate with latching mechanism for fast installation of barrier strips in ventilated RL/RS series cable trays. With M6 locking stud.

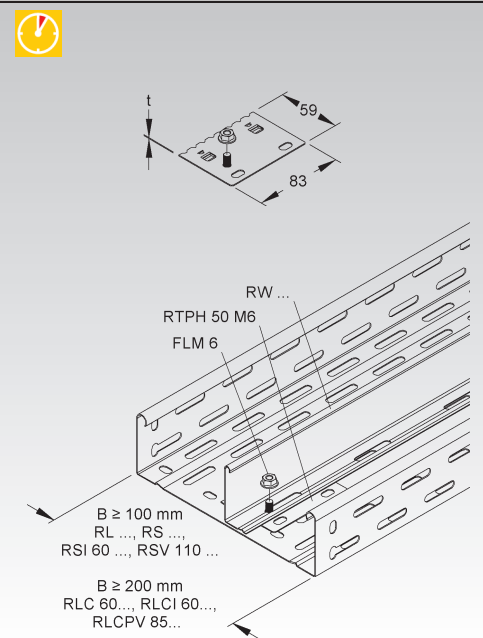

Extension Horizontal Tee

with integrated splice

	model no.	height H		inside dimension (B)		Weight per 100 pcs/pc. kg	Pack/Box Qty
		mm	Inch	mm	Inch		
S	RTA 60.100	60	2,4	102	4	78,00	1
S	RTA 60.150	60	2,4	152	6	86,50	1
S	RTA 60.200	60	2,4	202	8	94,90	1
S	RTA 60.300	60	2,4	302	11,9	111,90	1
S	RTA 60.400	60	2,4	402	15,8	129,10	1
S	RTA 60.500	60	2,4	502	19,8	145,50	1
S	RTA 60.600	60	2,4	602	23,7	162,40	1
F	RTA 60.100 F	60	2,4	102	4	85,00	1
F	RTA 60.150 F	60	2,4	152	6	94,40	1
F	RTA 60.200 F	60	2,4	202	8	104,63	1
F	RTA 60.300 F	60	2,4	302	11,9	122,30	1
F	RTA 60.400 F	60	2,4	402	15,8	141,20	1
F	RTA 60.500 F	60	2,4	502	19,8	159,30	1
F	RTA 60.600 F	60	2,4	602	23,7	177,80	1
E3	RTA 60.100 E3	60	2,4	102	4	70,70	1
E3	RTA 60.200 E3	60	2,4	202	8	86,84	1
E3	RTA 60.300 E3	60	2,4	302	11,9	100,90	1
E3	RTA 60.400 E3	60	2,4	402	15,8	135,60	1
E3	RTA 60.500 E3	60	2,4	502	19,8	154,00	1
E3	RTA 60.600 E3	60	2,4	602	23,7	173,00	1

Height 60 mm
Nominal 2 3/8 inches

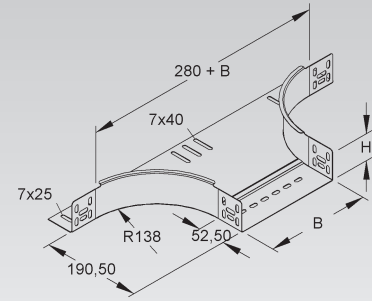

Horizontal Elbow Building Block

with integrated splice

	model no.	height H		Weight per 100 pcs kg	Pack/Box Qty
		mm	Inch		
S	REK 60	60	2,4	37,60	10
F	REK 60 F	60	2,4	40,10	10
E3	REK 60 E3	60	2,4	34,73	10
E5	REK 60 E5	60	2,4	34,40	10

for building customized horizontal cable tray fittings

Height 60 mm
Nominal 2 3/8 inches

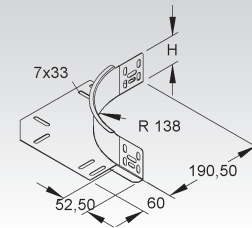

Flexible Horizontal Elbow 0-90°

with integrated splice

	model no.	height H		inside dimension (B)		Weight per 100 pcs/pc. kg	Pack/Box Qty
		mm	Inch	mm	Inch		
S	RBAV 60.100	60	2,4	100	3,9	44,11	1
S	RBAV 60.150	60	2,4	150	5,9	58,15	1
S	RBAV 60.200	60	2,4	200	7,9	73,71	1
S	RBAV 60.300	60	2,4	300	11,8	115,39	1
S	RBAV 60.400	60	2,4	400	15,7	167,07	1
S	RBAV 60.500	60	2,4	500	19,7	237,47	1
S	RBAV 60.600	60	2,4	600	23,6	315,84	1

Height 60 mm
Nominal 2 3/8 inches

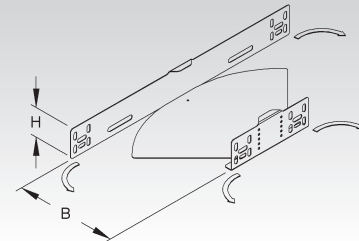

CABLE TRAY SYSTEM

Horizontal Elbow 45°

with integrated splice

model no.		height H	inside dimension (B)	Weight per 100 pcs./pc. kg	Pack/Box Qty
		mm Inch	mm Inch		
S	RBA 60.100	60 2,4	102 4	42,90	1
S	RBA 60.150	60 2,4	152 6	57,00	1
S	RBA 60.200	60 2,4	202 8	72,80	1
S	RBA 60.300	60 2,4	302 11,9	109,10	1
S	RBA 60.400	60 2,4	402 15,8	152,10	1
S	RBA 60.500	60 2,4	502 19,8	205,43	1
S	RBA 60.600	60 2,4	602 23,7	260,46	1
F	RBA 60.100 F	60 2,4	102 4	50,14	1
F	RBA 60.150 F	60 2,4	152 6	46,00	1
F	RBA 60.200 F	60 2,4	202 8	83,61	1
F	RBA 60.300 F	60 2,4	302 11,9	117,40	1
F	RBA 60.400 F	60 2,4	402 15,8	163,60	1
F	RBA 60.500 F	60 2,4	502 19,8	216,60	1
F	RBA 60.600 F	60 2,4	602 23,7	276,80	1

Height 60 mm
Nominal 2 3/8 inches

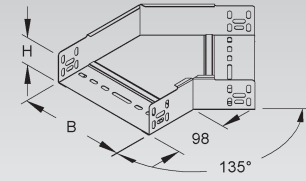

Horizontal Elbow 90°

with integrated splice

model no.		height H	inside dimension (B)	Weight per 100 pcs./pc. kg	Pack/Box Qty
		mm Inch	mm Inch		
S	RES 60.100	60 2,4	102 4	87,50	1
S	RES 60.150	60 2,4	152 6	115,70	1
S	RES 60.200	60 2,4	202 8	156,80	1
S	RES 60.300	60 2,4	302 11,9	237,70	1
S	RES 60.400	60 2,4	402 15,8	333,80	1
S	RES 60.500	60 2,4	502 19,8	446,10	1
S	RES 60.600	60 2,4	602 23,7	574,00	1
F	RES 60.100 F	60 2,4	102 4	99,42	1
F	RES 60.150 F	60 2,4	152 6	125,00	1
F	RES 60.200 F	60 2,4	202 8	176,54	1
F	RES 60.300 F	60 2,4	302 11,9	265,49	1
F	RES 60.400 F	60 2,4	402 15,8	358,90	1
F	RES 60.500 F	60 2,4	502 19,8	479,50	1
F	RES 60.600 F	60 2,4	602 23,7	617,10	1
E3	RES 60.100 E3	60 2,4	102 4	81,52	1
E3	RES 60.200 E3	60 2,4	202 8	135,39	1
E3	RES 60.300 E3	60 2,4	302 11,9	201,53	1
E3	RES 60.400 E3	60 2,4	402 15,8	280,78	1
E3	RES 60.500 E3	60 2,4	502 19,8	372,20	1
E3	RES 60.600 E3	60 2,4	602 23,7	476,26	1

Height 60 mm
Nominal 2 3/8 inches

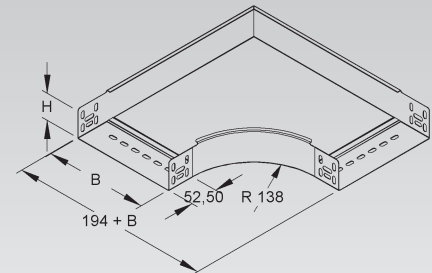

Horizontal Tee

with integrated splice

model no.		height H	inside dimension (B)	Weight per 100 pcs./pc. kg	Pack/Box Qty
		mm Inch	mm Inch		
S	RTS 60.100	60 2,4	102 4	115,40	1
S	RTS 60.150	60 2,4	152 6	147,20	1
S	RTS 60.200	60 2,4	202 8	195,40	1
S	RTS 60.300	60 2,4	302 11,9	294,80	1
S	RTS 60.400	60 2,4	402 15,8	399,68	1
S	RTS 60.500	60 2,4	502 19,8	511,90	1
S	RTS 60.600	60 2,4	602 23,7	648,80	1
F	RTS 60.100 F	60 2,4	102 4	133,41	1
F	RTS 60.150 F	60 2,4	152 6	159,00	1
F	RTS 60.200 F	60 2,4	202 8	210,00	1
F	RTS 60.300 F	60 2,4	302 11,9	322,62	1
F	RTS 60.400 F	60 2,4	402 15,8	420,00	1
F	RTS 60.500 F	60 2,4	502 19,8	550,30	1
F	RTS 60.600 F	60 2,4	602 23,7	697,50	1

Height 60 mm
Nominal 2 3/8 inches

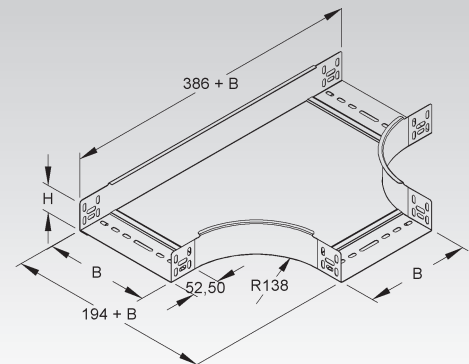

Horizontal Cross

with integrated splice

	model no.	height H		inside dimension (B)		Weight per 100 pcs/pc. kg	Pack/Box Qty
		mm	Inch	mm	Inch		
S	RKS 60.100	60	2,4	102	4	159,37	1
S	RKS 60.150	60	2,4	152	6	190,20	1
S	RKS 60.200	60	2,4	202	8	233,70	1
S	RKS 60.300	60	2,4	302	11,9	332,40	1
S	RKS 60.400	60	2,4	402	15,8	460,47	1
S	RKS 60.500	60	2,4	502	19,8	577,10	1
S	RKS 60.600	60	2,4	602	23,7	722,90	1
F	RKS 60.100 F	60	2,4	102	4	161,90	1
F	RKS 60.150 F	60	2,4	152	6	205,00	1
F	RKS 60.200 F	60	2,4	202	8	251,20	1
F	RKS 60.300 F	60	2,4	302	11,9	357,40	1
F	RKS 60.400 F	60	2,4	402	15,8	480,40	1
F	RKS 60.500 F	60	2,4	502	19,8	620,30	1
F	RKS 60.600 F	60	2,4	602	23,7	777,10	1

Height 60 mm
Nominal 2 3/8 inches

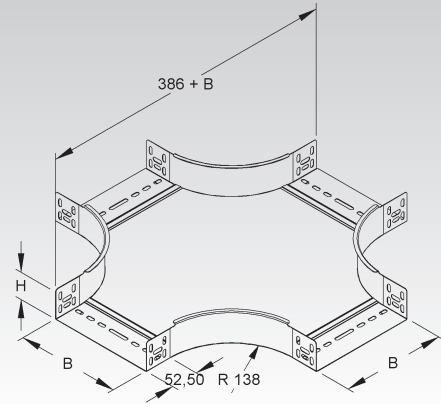

Reducer/Blind End

	model no.	height H		width B		width B1		Weight per 100 pcs/pc. kg	Pack/Box Qty
		mm	Inch	mm	Inch	mm	Inch		
S	RA 60.050	60	2,4	50	2	172	6,8	11,1	20
S	RA 60.150	60	2,4	150	5,9	272	10,7	17,0	20
S	RA 60.200	60	2,4	200	7,9	322	12,7	19,9	20
S	RA 60.400	60	2,4	400	15,7	522	20,6	31,8	20
S	RA 60.500	60	2,4	500	19,7	622	24,5	37,7	20
S	RA 60.600	60	2,4	600	23,6	722	28,4	43,7	20
F	RA 60.150 F	60	2,4	150	5,9	272	10,7	18,4	1
F	RA 60.200 F	60	2,4	200	7,9	322	12,7	21,6	1
F	RA 60.400 F	60	2,4	400	15,7	522	20,6	34,7	1
F	RA 60.500 F	60	2,4	500	19,7	622	24,5	41,2	1
F	RA 60.600 F	60	2,4	600	23,6	722	28,4	47,7	1
E3	RA 60.200 E3	60	2,4	200	7,9	322	12,7	18,1	20
E3	RA 60.400 E3	60	2,4	400	15,7	522	20,6	32,0	20
E3	RA 60.500 E3	60	2,4	500	19,7	622	24,5	39,0	20
E3	RA 60.600 E3	60	2,4	600	23,6	722	28,4	46,0	20

Height 60 mm
Nominal 2 3/8 inches

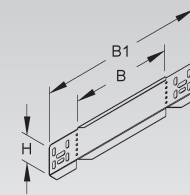

can be used as blind end or as reducer for cable trays

Adjustable Horizontal Splice/Reducer/Blind End

	model no.	height H		width B		width B1		Weight per 100 pcs kg	Pack/Box Qty
		mm	Inch	mm	Inch	mm	Inch		
S	RAW 60.100	60	2,4	100	3,9	222	8,7	13,00	20
S	RAW 60.300	60	2,4	300	11,8	422	16,6	25,76	20
F	RAW 60.100 F	60	2,4	100	3,9	222	8,7	14,80	1
F	RAW 60.300 F	60	2,4	300	11,8	422	16,6	26,00	1
E3	RAW 60.100 E3	60	2,4	100	3,9	222	8,7	13,00	20
E3	RAW 60.300 E3	60	2,4	300	11,8	422	16,6	26,00	20

Height 60 mm
Nominal 2 3/8 inches

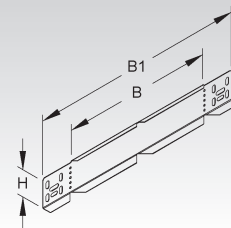

can be used as blind end or as reducer for cable trays

Adjustable Vertical Splice Plate

	model no.	height H		Weight per 100 pcs kg	Pack/Box Qty
		mm	Inch		
S	RGV 60	47	1,9	19,23	50
F	RGV 60 F	47	1,9	20,58	50
E3	RGV 60 E3	47	1,9	14,38	20

Height 60 mm
Nominal 2 3/8 inches

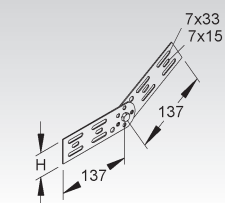

2 pieces required per joint

CABLE TRAY SYSTEM

Splice/Link Kit

model no.		height H	width B	Weight per 100 pcs./pc. kg	Pack/ Box Qty
		mm Inch	mm Inch		
S	RGE 60.100	60 2,4	100 3,9	52,51	1
S	RGE 60.150	60 2,4	150 5,9	57,65	1
S	RGE 60.200	60 2,4	200 7,9	62,79	1
S	RGE 60.300	60 2,4	300 11,8	73,07	1
S	RGE 60.400	60 2,4	400 15,7	83,35	1
S	RGE 60.500	60 2,4	500 19,7	93,63	1
S	RGE 60.600	60 2,4	600 23,6	103,91	1
F	RGE 60.100 F	60 2,4	100 3,9	57,42	1
F	RGE 60.150 F	60 2,4	150 5,9	63,07	1
F	RGE 60.200 F	60 2,4	200 7,9	68,73	1
F	RGE 60.300 F	60 2,4	300 11,8	80,03	1
F	RGE 60.400 F	60 2,4	400 15,7	91,34	1
F	RGE 60.500 F	60 2,4	500 19,7	102,65	1
F	RGE 60.600 F	60 2,4	600 23,6	113,96	1

for linking sections of tray with a vertical displacement

Height
60
mm

Nominal
2 3/8
inches

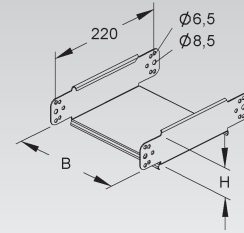

Vertical Inside Elbow 90°

with integrated splice

model no.		height H	inside dimension (B)	Weight per 100 pcs./pc. kg	Pack/ Box Qty
		mm Inch	mm Inch		
S	RSD 60.100	60 2,4	102 4	78,00	1
S	RSD 60.150	60 2,4	152 6	95,19	1
S	RSD 60.200	60 2,4	202 8	113,30	1
S	RSD 60.300	60 2,4	302 11,9	147,68	1
S	RSD 60.400	60 2,4	402 15,8	182,98	1
S	RSD 60.500	60 2,4	502 19,8	217,36	1
S	RSD 60.600	60 2,4	602 23,7	251,74	1
F	RSD 60.100 F	60 2,4	102 4	85,98	1
F	RSD 60.200 F	60 2,4	202 8	124,86	1
F	RSD 60.300 F	60 2,4	302 11,9	162,68	1
F	RSD 60.400 F	60 2,4	402 15,8	201,55	1
F	RSD 60.500 F	60 2,4	502 19,8	239,37	1
F	RSD 60.600 F	60 2,4	602 23,7	277,19	1

Height
60
mm

Nominal
2 3/8
inches

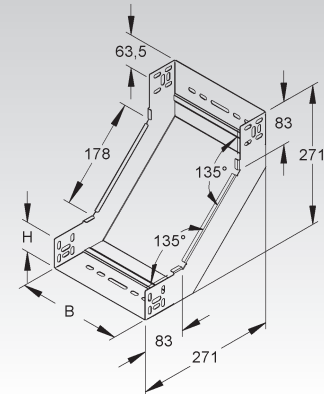

Vertical Outside Elbow 90°

with integrated splice

model no.		height H	inside dimension (B)	Weight per 100 pcs./pc. kg	Pack/ Box Qty
		mm Inch	mm Inch		
S	RFD 60.100	60 2,4	102 4	71,70	1
S	RFD 60.150	60 2,4	152 6	85,06	1
S	RFD 60.200	60 2,4	202 8	99,22	1
S	RFD 60.300	60 2,4	302 11,9	125,95	1
S	RFD 60.400	60 2,4	402 15,8	153,47	1
S	RFD 60.500	60 2,4	502 19,8	180,19	1
S	RFD 60.600	60 2,4	602 23,7	206,91	1
F	RFD 60.100 F	60 2,4	102 4	78,95	1
F	RFD 60.200 F	60 2,4	202 8	109,24	1
F	RFD 60.300 F	60 2,4	302 11,9	138,65	1
F	RFD 60.400 F	60 2,4	402 15,8	168,94	1
F	RFD 60.500 F	60 2,4	502 19,8	198,33	1
F	RFD 60.600 F	60 2,4	602 23,7	227,72	1

Height
60
mm

Nominal
2 3/8
inches

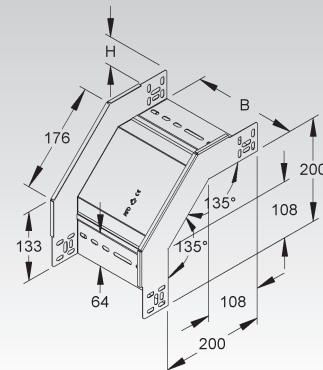

Vertical Tee Down, lengthwise

with integrated splice

	model no.	height H		width B		length A		Weight per 100 pcs./pc. kg	Pack/Box Qty
		mm	Inch	mm	Inch	mm	Inch		
S	RTL 60.100	60	2,4	100	3,9	201	7,9	152,49	1
S	RTL 60.150	60	2,4	150	5,9	251	9,9	186,97	1
S	RTL 60.200	60	2,4	200	7,9	401	15,8	263,28	1
S	RTL 60.300	60	2,4	300	11,8	701	27,6	519,06	1
S	RTL 60.400	60	2,4	400	15,7	801	31,5	664,44	1
S	RTL 60.500	60	2,4	500	19,7	901	35,5	818,83	1
S	RTL 60.600	60	2,4	600	23,6	1001	39,4	988,21	1

Size of run and tap tray is identical.

Height 60 mm
Nominal 2 3/8 inches

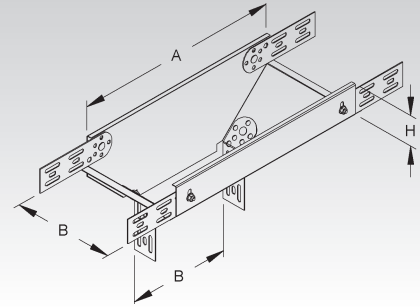

Vertical Tee Down, crosswise

with integrated splice

	model no.	height H		inside dimension (B)	length A		Weight per 100 pcs./pc. kg	Pack/Box Qty	
		mm	Inch		mm	Inch			
S	RTQ 60.100	60	2,4	102	4	311	12,2	100,75	1
S	RTQ 60.150	60	2,4	152	6	311	12,2	118,03	1
S	RTQ 60.200	60	2,4	202	8	311	12,2	136,91	1
S	RTQ 60.300	60	2,4	302	11,9	311	12,2	173,07	1
S	RTQ 60.400	60	2,4	402	15,8	311	12,2	207,63	1
S	RTQ 60.500	60	2,4	502	19,8	311	12,2	242,19	1
S	RTQ 60.600	60	2,4	602	23,7	311	12,2	276,75	1

Size of run and tap tray is identical.

Height 60 mm
Nominal 2 3/8 inches

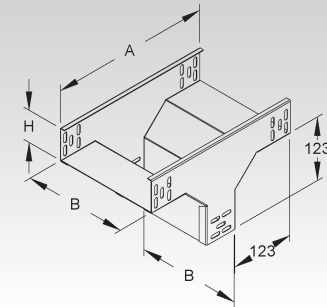

Edge Protection Plate

	model no.	width B		Weight per 100 pcs. kg	Pack/Box Qty
		mm	Inch		
S	RKB 100	92	3,6	4,22	10
S	RKB 150	142	5,6	6,82	10
S	RKB 200	192	7,6	8,77	10
S	RKB 300	292	11,5	12,84	10
S	RKB 400	392	15,4	16,91	10
S	RKB 500	492	19,4	20,98	10
S	RKB 600	592	23,3	25,05	10
F	RKB 100 F	92	3,6	4,66	50
F	RKB 150 F	142	5,6	7,54	50
F	RKB 200 F	192	7,6	9,69	50
F	RKB 300 F	292	11,5	14,16	50
F	RKB 400 F	392	15,4	18,64	50
F	RKB 500 F	492	19,4	23,12	50
F	RKB 600 F	592	23,3	27,60	50

with rounded edges to protect cables at the joint and to reinforce the bottom of cable trays

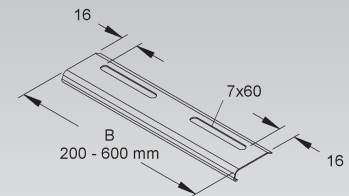

CABLE TRAY SYSTEM

Available Side Rail Heights



SYSTEM			
	Cable Tray	RL...	Page 189
	Cable Tray	RLU...	Page 189
	Distribution Cable Tray	RLCPV...	Page 190
	Heavy Duty Cable Tray	RS...	Page 191
	Heavy Duty Cable Tray	RSU...	Page 191
ZUBEHÖR	Boltless Splice Plate	RVC 85	Page 190
	Edge Protection Ring	KSR 40 A	Page 190
	★ Universal Splice Plate	RSUV 85-1.5/200 S	Page 191
	U-shaped Splice Plate	RV...	Page 192
	Barrier Strip	RW 85...	Page 192
	Splice Plate Barrier Strip	RTV 85 E2	Page 192
	Mounting Plate for Barrier Strip	RTPH 50+M6	Page 192/193
	Extension Horizontal Tee	RTA...	Page 193
	Horizontal Elbow Building Block	REK...	Page 193
	Flexible Horizontal Elbow 0-90°	RBAV...	Page 194
	Horizontal Elbow 45°	RBA...	Page 194
	Horizontal Elbow 90°	RES...	Page 194
	Horizontal Tee	RTS...	Page 194
	Horizontal Cross	RKS...	Page 195
	Reducer/Blind End	RA...	Page 195
	Adjustable Horizontal Splice/Reducer/Blind End	RAW...	Page 195
	Adjustable Vertical Splice Plate	RGV...	Page 195
	Splice/Link Kit	RGE...	Page 196
	Vertical Inside Elbow 90°	RSD...	Page 196
	Vertical Outside Elbow 90°	RFD...	Page 196
	Vertical Tee Down, lengthwise	RTL...	Page 197
	Vertical Tee Down, crosswise	RTQ...	Page 197
	Edge Protection Plate	RKB...	Page 197

See covers for cable trays and fittings on page 212 and following.



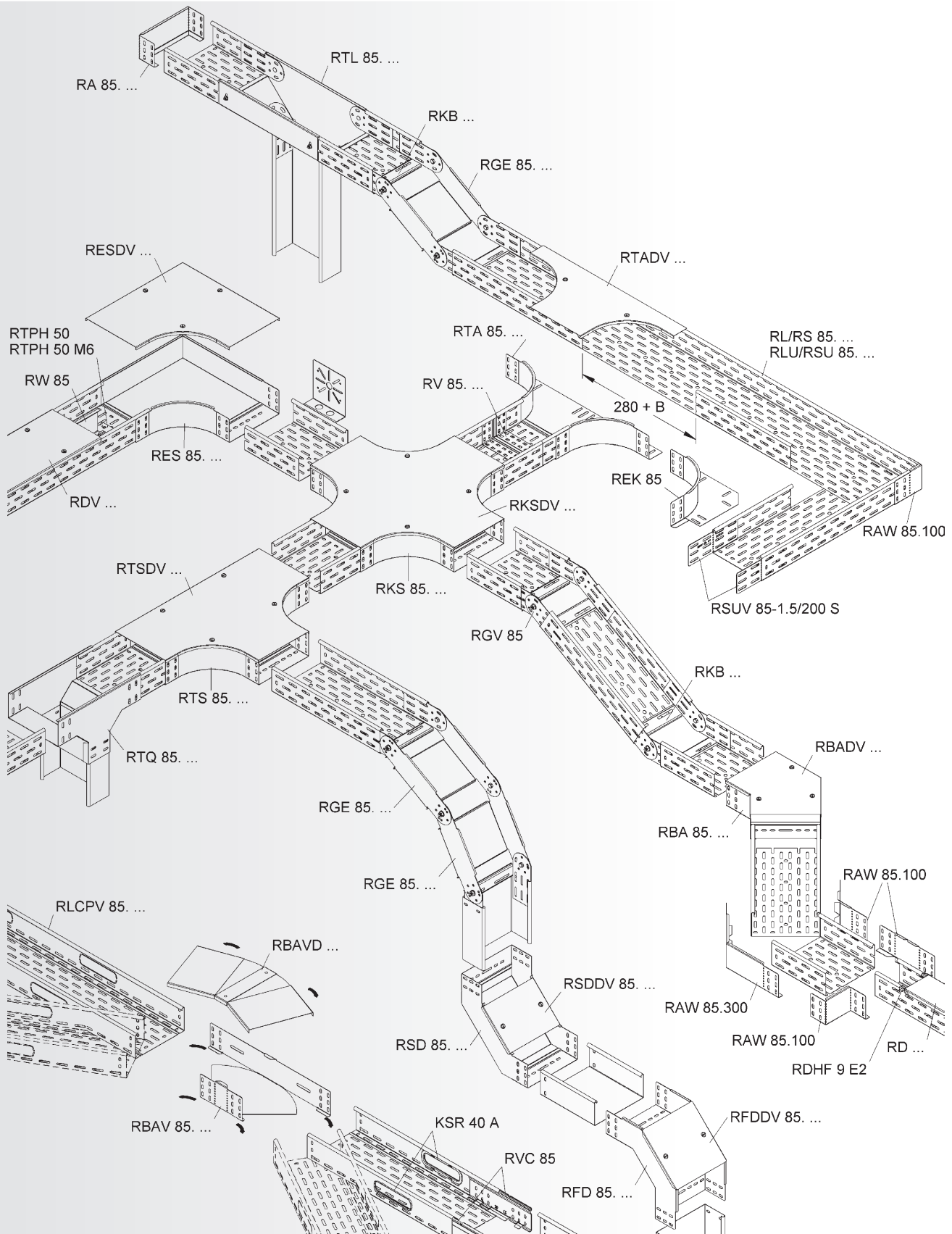

 **Load/Span Class Designation in accordance with NEMA VE 1 and CSA E22.2 No. 126.1**

Niedax Series	Minimum Area		Load class in accordance to NEMA VE 1		
	(calculational) mm ² / in. ²	in accordance to NEMA VE 2 mm ² / in. ²	Rated Load Kg/m / lb./ft.	Support spacing m / ft.	Load/Span Class
RLX 85.100, ... F	201.6 / 0.31	129 / 0.2	93 / 62.5	2 / 6.6	A
RLX 85.200, ... F	296.0 / 0.46	258 / 0.4	93 / 62.5	2 / 6.6	A
RLX 85.300, ... F	368.0 / 0.57	258 / 0.4	93 / 62.5	2 / 6.6	A
RLX 85.400, ... F	440.0 / 0.68	258 / 0.4	92 / 62.5	2 / 6.6	A
RLX 85.500, ... F	512.0 / 0.79	452 / 0.7	93 / 62.5	2 / 6.6	A
RLX 85.600, ... F	584.0 / 0.91	452 / 0.7	93 / 62.5	2 / 6.6	A
RLUX 85.100, ... F	264,6 / 0.41	258 / 0.4	93 / 62.5	2 / 6.6	A
RLUX 85.200, ... F	394.0 / 0.61	258 / 0.4	93 / 62.5	2 / 6.6	A
RLUX 85.300, ... F	494.0 / 0.77	452 / 0.7	93 / 62.5	2 / 6.6	A
RLUX 85.400, ... F	594.0 / 0.92	452 / 0.7	93 / 62.5	2 / 6.6	A
RLUX 85.500, ... F	694.0 / 1.08	645 / 1.0	93 / 62.5	2 / 6.6	A
RLUX 85.600, ... F	794.0 / 1.23	645 / 1.0	93 / 62.5	2 / 6.6	A
RLCPVX 85.100 OV	186.0 / 0.29	129 / 0.2	116 / 78.4	2.4 / 8	8B
RLCPVX 85.200 OV	272.0 / 0.42	258 / 0.4	116 / 78.4	2.4 / 8	8B
RLCPVX 85.300 OV	358.0 / 0.55	258 / 0.4	116 / 78.4	2.4 / 8	8B
RLCPVX 85.400 OV	444.0 / 0.69	258 / 0.4	116 / 78.4	2.4 / 8	8B
RLCPVX 85.500 OV	530.0 / 0.82	452 / 0.7	116 / 78.4	2.4 / 8	8B
RLCPVX 85.600 OV	616.0 / 0.95	452 / 0.7	116 / 78.4	2.4 / 8	8B
RSX 85.100, ... F	331.5 / 0.51	258 / 0.4	266.5 / 179	2 / 6.6	A
RSX 85.200, ... F	439.5 / 0.68	258 / 0.4	266.5 / 179	2 / 6.6	A
RSX 85.300, ... F	547.5 / 0.85	452 / 0.7	266.5 / 179	2 / 6.6	A
RSX 85.400, ... F	655.5 / 1.02	645 / 1.0	266.5 / 179	2 / 6.6	A
RSX 85.500, ... F	763.5 / 1.18	645 / 1.0	266.5 / 179	2 / 6.6	A
RSX 85.600, ... F	871.5 / 1.35	645 / 1.0	266.5 / 179	2 / 6.6	A
RSUX 85.100, ... F	436.5 / 0.68	258 / 0.4	266.5 / 179	2 / 6.6	A
RSUX 85.200, ... F	586.5 / 0.91	452 / 0.7	266.5 / 179	2 / 6.6	A
RSUX 85.300, ... F	736.5 / 1.14	645 / 1.0	266.5 / 179	2 / 6.6	A
RSUX 85.400, ... F	886.5 / 1.37	645 / 1.0	266.5 / 179	2 / 6.6	A
RSUX 85.500, ... F	1036.5 / 1.61	968 / 1.5	266.5 / 179	2 / 6.6	A
RSUX 85.600, ... F	1186.5 / 1.84	968 / 1.5	266.5 / 179	2 / 6.6	A



Cable Tray

ventilated

	model no.	height H		width B		thickness t mm	Weight per 100 m kg	Pack/ Box Qty
		mm	Inch	mm	Inch			
S	RL 85.100	85	3,3	100	3,9	0,9	185,56	2 x 3 m
S	RL 85.200	85	3,3	200	7,9	1,0	272,98	2 x 3 m
S	RL 85.300	85	3,3	300	11,8	1,0	340,52	2 x 3 m
S	RL 85.400	85	3,3	400	15,7	1,0	407,71	2 x 3 m
S	RL 85.500	85	3,3	500	19,7	1,0	474,00	2 x 3 m
S	RL 85.600	85	3,3	600	23,6	1,0	542,00	2 x 3 m
F	RL 85.100 F	85	3,3	100	3,9	0,9	207,00	2 x 3 m
F	RL 85.200 F	85	3,3	200	7,9	1,0	272,00	2 x 3 m
F	RL 85.300 F	85	3,3	300	11,8	1,0	329,00	2 x 3 m
F	RL 85.400 F	85	3,3	400	15,7	1,0	405,00	2 x 3 m
F	RL 85.500 F	85	3,3	500	19,7	1,0	474,00	2 x 3 m
F	RL 85.600 F	85	3,3	600	23,6	1,0	542,00	2 x 3 m

Centered punchholes allow hanging with M10 (3/8") threaded rod.
Bottom plate and side rail perforated with staggered punch holes. Extra 7/16" punch holes (11 mm) for center hanging with threaded rod.

One RV... splice plate included with every piece of cable tray.

Load Chart: q = uniformly distributed load (tested according to DIN EN IEC 61537 standard)

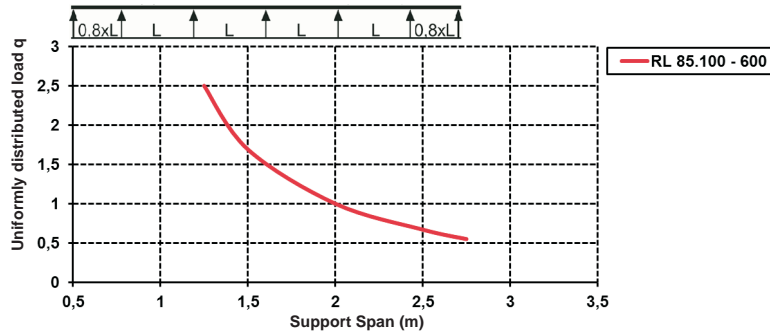

Height
85 mm
Nominal
3 3/8 inches

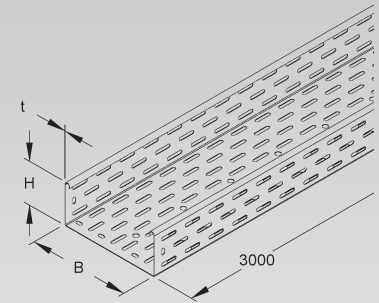

Cable Tray

solid, but with splice plate perforation

	model no.	height H		width B		thickness t mm	Weight per 100 m kg	Pack/ Box Qty
		mm	Inch	mm	Inch			
S	RLU 85.100	85	3,3	100	3,9	0,9	214,51	2 x 3 m
S	RLU 85.200	85	3,3	200	7,9	1,0	319,05	2 x 3 m
S	RLU 85.300	85	3,3	300	11,8	1,0	399,56	2 x 3 m
S	RLU 85.400	85	3,3	400	15,7	1,0	480,60	2 x 3 m
S	RLU 85.500	85	3,3	500	19,7	1,0	561,15	2 x 3 m
S	RLU 85.600	85	3,3	600	23,6	1,0	641,70	2 x 3 m
F	RLU 85.100 F	85	3,3	100	3,9	0,9	236,87	2 x 3 m
F	RLU 85.200 F	85	3,3	200	7,9	1,0	350,99	2 x 3 m
F	RLU 85.300 F	85	3,3	300	11,8	1,0	439,58	2 x 3 m
F	RLU 85.400 F	85	3,3	400	15,7	1,0	528,71	2 x 3 m
F	RLU 85.500 F	85	3,3	500	19,7	1,0	617,31	2 x 3 m
F	RLU 85.600 F	85	3,3	600	23,6	1,0	705,92	2 x 3 m

One RV... splice plate included with every piece of cable tray.

Height
85 mm
Nominal
3 3/8 inches

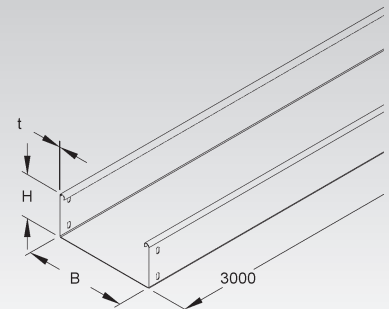

CABLE TRAY SYSTEM

Distribution Cable Tray

ventilated

	model no.	height H		width B		thick-ness t mm	Weight per 100 m kg	Pack/Box Qty
		mm	Inch	mm	Inch			
S	RLCPV 85.100 OV	85	3,3	100	3,9	1	210,65	2 x 3 m
S	RLCPV 85.200 OV	85	3,3	200	7,9	1	276,15	2 x 3 m
S	RLCPV 85.300 OV	85	3,3	300	11,8	1	341,65	2 x 3 m
S	RLCPV 85.400 OV	85	3,3	400	15,7	1	407,15	2 x 3 m
S	RLCPV 85.500 OV	85	3,3	500	19,7	1	472,65	2 x 3 m
S	RLCPV 85.600 OV	85	3,3	600	23,6	1	538,15	2 x 3 m

With pre-cut cable drop outs, size 40 mm x 150 mm.

Please order two RVC 85 splice plates for every piece of tray.

Load Chart: q = uniformly distributed load (tested according to DIN EN IEC 61537 standard)

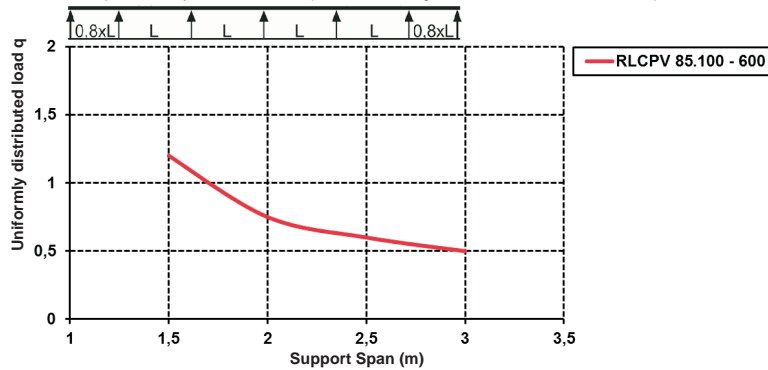

Height 85 mm
Nominal 3 3/8 inches
52

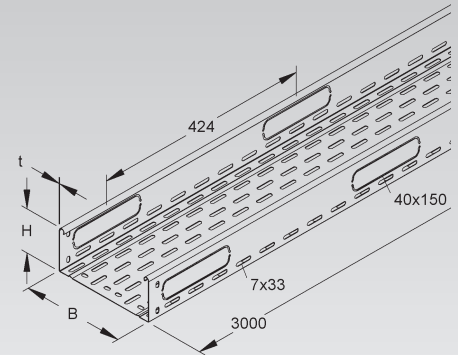

Boltless Splice Plate

	model no.	height H		Weight per 100 pcs kg	Pack/Box Qty
		mm	Inch		
S	RVC 85	85	3,3	23,54	50

2 pieces required per joint

Suitable for: RLCPV 85... OV cable trays

Height 85 mm
Nominal 3 3/8 inches

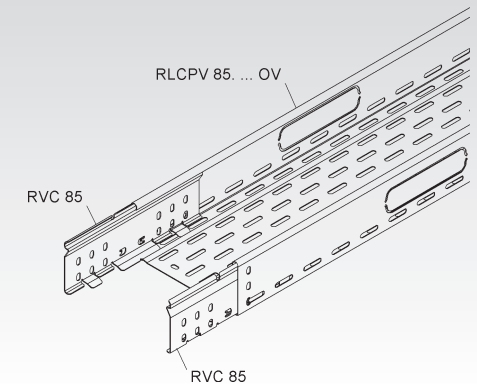
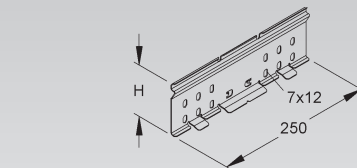

Edge Protection Ring

UV resistant

	model no.	color	inside height H		inside dimension (B)		Weight per 100 pcs kg	Pack/Box Qty
			mm	Inch	mm	Inch		
K04	KSR 40 A	black	34,5	1,4	144,5	5,7	0,97	20

to protect cables at the knockouts of tray or surface metal raceways

Suitable for: RLCPV 85... OV and RSV 110... distribution cable tray

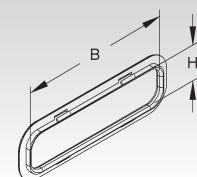

Heavy Duty Cable Tray

ventilated

	model no.	height H		width B		thick-ness t	Weight per 100 m	Pack/Box Qty
		mm	Inch	mm	Inch			
S	RS 85.100	85	3,3	100	3,9	1,5	299,79	2 x 3 m
S	RS 85.200	85	3,3	200	7,9	1,5	400,60	2 x 3 m
S	RS 85.300	85	3,3	300	11,8	1,5	500,89	2 x 3 m
S	RS 85.400	85	3,3	400	15,7	1,5	601,70	2 x 3 m
S	RS 85.500	85	3,3	500	19,7	1,5	701,99	2 x 3 m
S	RS 85.600	85	3,3	600	23,6	1,5	802,27	2 x 3 m
F	RS 85.100 F	85	3,3	100	3,9	1,5	310,00	2 x 3 m
F	RS 85.200 F	85	3,3	200	7,9	1,5	414,00	2 x 3 m
F	RS 85.300 F	85	3,3	300	11,8	1,5	480,00	2 x 3 m
F	RS 85.400 F	85	3,3	400	15,7	1,5	662,02	2 x 3 m
F	RS 85.500 F	85	3,3	500	19,7	1,5	744,00	2 x 3 m
F	RS 85.600 F	85	3,3	600	23,6	1,5	857,00	2 x 3 m

Centered punchholes allow hanging with M10 (3/8") threaded rod.
Bottom plate and side rail perforated with staggered punch holes. Extra 7/16" punch holes (11 mm) for center hanging with threaded rod.

One RV... splice plate included with every piece of cable tray.

Load Chart: q = uniformly distributed load (tested according to DIN EN IEC 61537 standard)

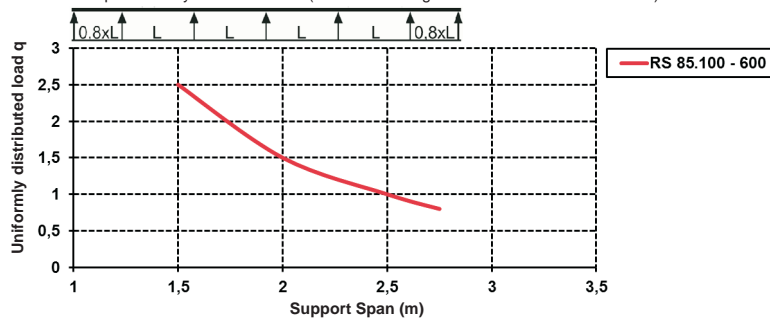

Height 85 mm
Nominal 3 3/8 inches

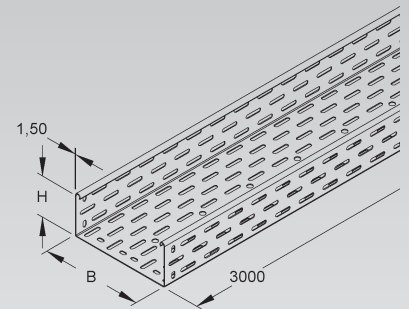

Heavy Duty Cable Tray

solid, but with splice plate perforation

	model no.	height H		width B		thick-ness t	Weight per 100 m	Pack/Box Qty
		mm	Inch	mm	Inch			
S	RSU 85.100	85	3,3	100	3,9	1,5	349,75	2 x 3 m
S	RSU 85.200	85	3,3	200	7,9	1,5	470,08	2 x 3 m
S	RSU 85.300	85	3,3	300	11,8	1,5	589,82	2 x 3 m
S	RSU 85.400	85	3,3	400	15,7	1,5	710,09	2 x 3 m
S	RSU 85.500	85	3,3	500	19,7	1,5	829,89	2 x 3 m
S	RSU 85.600	85	3,3	600	23,6	1,5	949,69	2 x 3 m
F	RSU 85.100 F	85	3,3	100	3,9	1,5	384,74	2 x 3 m
F	RSU 85.200 F	85	3,3	200	7,9	1,5	517,12	2 x 3 m
F	RSU 85.300 F	85	3,3	300	11,8	1,5	648,87	2 x 3 m
F	RSU 85.400 F	85	3,3	400	15,7	1,5	781,14	2 x 3 m
F	RSU 85.500 F	85	3,3	500	19,7	1,5	912,92	2 x 3 m
F	RSU 85.600 F	85	3,3	600	23,6	1,5	1.044,70	2 x 3 m

One RV... splice plate included with every piece of cable tray.

Height 85 mm
Nominal 3 3/8 inches

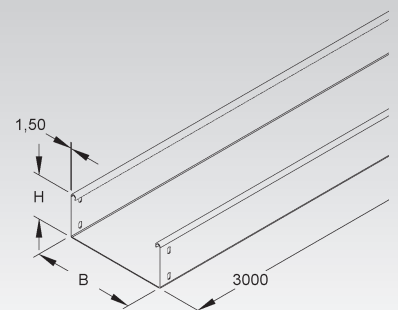

Universal Splice Plate

	model no.	height H		width B		thick-ness t	Weight per 100	Pack/Box Qty
		mm	Inch	mm	Inch			
★ S	RSUV 85-1.5/200 S	73	2,9	200	7,9	1,5	17,19	50

for straight and angled joints

Height 85 mm
Nominal 3 3/8 inches



62

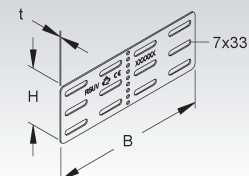

CABLE TRAY SYSTEM

U-shaped Splice Plate

	model no.	height H		width B		Weight per 100 pcs kg	Pack/Box Qty
		mm	Inch	mm	Inch		
S	RV 85.100	74	2,9	97	3,8	20,71	1
S	RV 85.200	74	2,9	197	7,8	28,44	1
S	RV 85.300	74	2,9	297	11,7	34,58	1
S	RV 85.400	74	2,9	397	15,6	42,31	1
S	RV 85.500	74	2,9	497	19,6	48,45	1
S	RV 85.600	74	2,9	597	23,5	54,59	1
F	RV 85.100 F	74	2,9	97	3,8	22,14	1
F	RV 85.200 F	74	2,9	197	7,8	30,48	1
F	RV 85.300 F	74	2,9	297	11,7	37,24	1
F	RV 85.400 F	74	2,9	397	15,6	45,58	1
F	RV 85.500 F	74	2,9	497	19,6	52,34	1
F	RV 85.600 F	74	2,9	597	23,5	59,09	1

Suitable for: RL/RS... cable trays

Height 85 mm
Nominal 3 3/8 inches

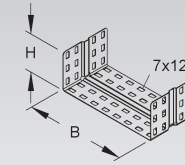

Barrier Strip

	model no.	height H		thickness t mm	Weight per 100 m kg	Pack/Box Qty
		mm	Inch			
S	RW 85	80	3,1	0,9	78,39	10 x 3 m
F	RW 85 F	80	3,1	0,9	86,12	10 x 3 m

to separate wires and cables of different voltage levels or with different functions

Height 85 mm
Nominal 3 3/8 inches



61

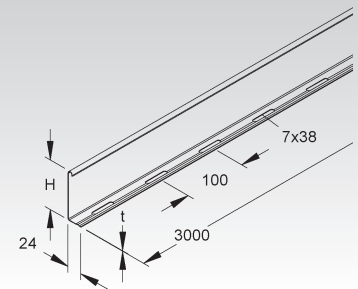

Splice Plate for Barrier Strip

	model no.	height H		length A		Weight per 100 pcs kg	Pack/Box Qty
		mm	Inch	mm	Inch		
E2	RTV 85 E2	79,5	3,1	80	3,1	2,03	20

for positive locking connections and proper bonding of barrier strips

Height 85 mm
Nominal 3 3/8 inches



61

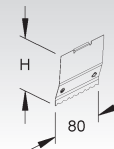

Mounting Plate for Barrier Strip

	model no.	length A		width B		thickness t mm	Weight per 100 pcs kg	Pack/Box Qty
		mm	Inch	mm	Inch			
S	RTPH 50	83	3,3	59	2,3	0,9	3,36	20

Mounting plate with latching mechanism for fast installation of barrier strips in ventilated RL/RS series cable trays.

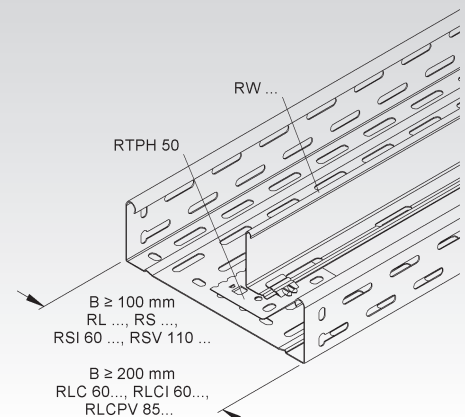

Mounting Plate for Barrier Strip with M6 Stud

model no.	length A		width B		thick-ness t mm	Weight per 100 pcs kg	Pack/Box Qty
	mm	Inch	mm	Inch			
S RTPH 50 M6	83	3,3	59	2,3	0,9	3,98	50

Mounting plate with latching mechanism for fast installation of barrier strips in ventilated RL/RS series cable trays. With M6 locking stud.

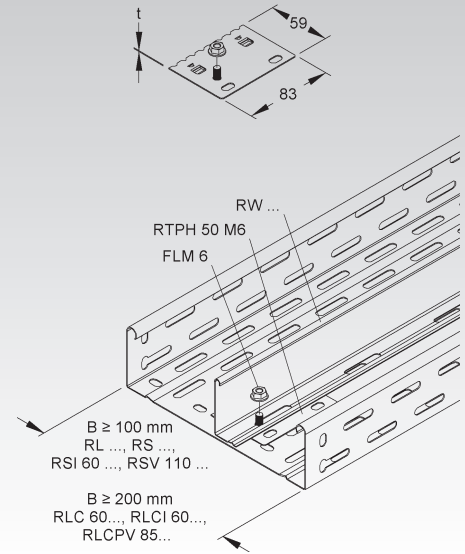

Extension Horizontal Tee

with integrated splice

model no.	height H	inside dimension (B)		Weight per 100 pcs kg	Pack/Box Qty	
		mm	Inch			
S RTA 85.100	85	3,3	102	4	94,6	1
S RTA 85.200	85	3,3	202	8	111,5	1
S RTA 85.300	85	3,3	302	11,9	128,4	1
S RTA 85.400	85	3,3	402	15,8	145,6	1
S RTA 85.500	85	3,3	502	19,8	162,1	1
S RTA 85.600	85	3,3	602	23,7	179,0	1
F RTA 85.100 F	85	3,3	102	4	103,3	1
F RTA 85.200 F	85	3,3	202	8	121,9	1
F RTA 85.300 F	85	3,3	302	11,9	140,4	1
F RTA 85.400 F	85	3,3	402	15,8	159,4	1
F RTA 85.500 F	85	3,3	502	19,8	177,5	1
F RTA 85.600 F	85	3,3	602	23,7	196,1	1

Height 85 mm
Nominal 3 3/8 inches

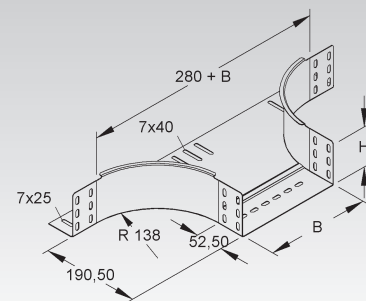

Horizontal Elbow Building Block

with integrated splice

model no.	height H	Weight per 100 pcs kg	Pack/Box Qty	
				mm
S REK 85	85	3,3	46,07	1
F REK 85 F	85	3,3	44,10	1

for building customized horizontal cable tray fittings

Height 85 mm
Nominal 3 3/8 inches

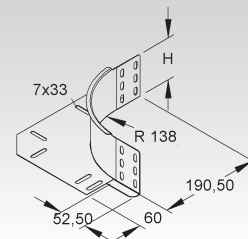

CABLE TRAY SYSTEM

Flexible Horizontal Elbow 0-90°

with integrated splice

	model no.	height H		inside dimension (B)		Weight per 100 pcs kg	Pack/Box Qty
		mm	Inch	mm	Inch		
S	RBAV 85.100	85	3,3	100	3,9	54,48	1
S	RBAV 85.200	85	3,3	200	7,9	86,81	1
S	RBAV 85.300	85	3,3	300	11,8	131,92	1
S	RBAV 85.400	85	3,3	400	15,7	186,69	1
S	RBAV 85.500	85	3,3	500	19,7	260,28	1
S	RBAV 85.600	85	3,3	600	23,6	341,84	1

Height 85 mm
Nominal 3 3/8 inches

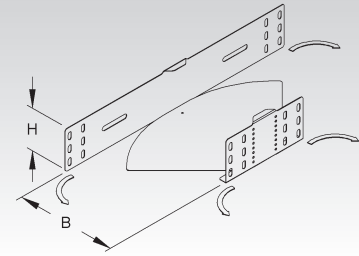

Horizontal Elbow 45°

with integrated splice

	model no.	height H		inside dimension (B)		Weight per 100 pcs kg	Pack/Box Qty
		mm	Inch	mm	Inch		
S	RBA 85.100	85	3,3	102	4	54,70	1
S	RBA 85.200	85	3,3	202	8	86,70	1
S	RBA 85.300	85	3,3	302	11,9	125,20	1
S	RBA 85.400	85	3,3	402	15,8	170,40	1
S	RBA 85.500	85	3,3	502	19,8	221,80	1
S	RBA 85.600	85	3,3	602	23,7	280,00	1
F	RBA 85.100 F	85	3,3	102	4	58,80	1
F	RBA 85.200 F	85	3,3	202	8	93,20	1
F	RBA 85.300 F	85	3,3	302	11,9	134,60	1
F	RBA 85.400 F	85	3,3	402	15,8	191,75	1
F	RBA 85.500 F	85	3,3	502	19,8	238,50	1
F	RBA 85.600 F	85	3,3	602	23,7	301,00	1

Height 85 mm
Nominal 3 3/8 inches

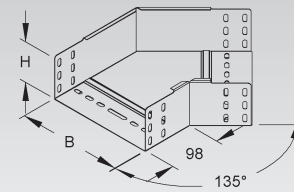

Horizontal Elbow 90°

with integrated splice

	model no.	height H		inside dimension (B)		Weight per 100 pcs kg	Pack/Box Qty
		mm	Inch	mm	Inch		
S	RES 85.100	85	3,3	102	4	110,50	1
S	RES 85.200	85	3,3	202	8	185,00	1
S	RES 85.300	85	3,3	302	11,9	271,10	1
S	RES 85.400	85	3,3	402	15,8	372,40	1
S	RES 85.500	85	3,3	502	19,8	489,90	1
S	RES 85.600	85	3,3	602	23,7	623,10	1
F	RES 85.100 F	85	3,3	102	4	125,16	1
F	RES 85.200 F	85	3,3	202	8	198,90	1
F	RES 85.300 F	85	3,3	302	11,9	291,40	1
F	RES 85.400 F	85	3,3	402	15,8	400,40	1
F	RES 85.500 F	85	3,3	502	19,8	526,60	1
F	RES 85.600 F	85	3,3	602	23,7	669,80	1

Height 85 mm
Nominal 3 3/8 inches

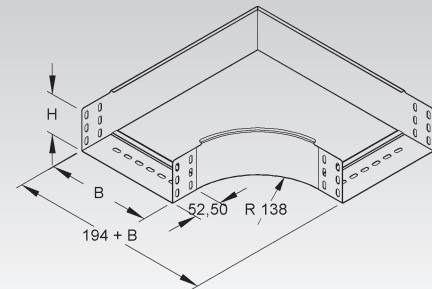

Horizontal Tee

with integrated splice

	model no.	height H		inside dimension (B)		Weight per 100 pcs kg	Pack/Box Qty
		mm	Inch	mm	Inch		
S	RTS 85.100	85	3,3	102	4	143,9	1
S	RTS 85.200	85	3,3	202	8	226,5	1
S	RTS 85.300	85	3,3	302	11,9	318,9	1
S	RTS 85.400	85	3,3	402	15,8	427,0	1
S	RTS 85.500	85	3,3	502	19,8	550,8	1
S	RTS 85.600	85	3,3	602	23,7	690,3	1
F	RTS 85.100 F	85	3,3	102	4	154,6	1
F	RTS 85.200 F	85	3,3	202	8	243,4	1
F	RTS 85.300 F	85	3,3	302	11,9	342,8	1
F	RTS 85.400 F	85	3,3	402	15,8	459,0	1
F	RTS 85.500 F	85	3,3	502	19,8	592,1	1
F	RTS 85.600 F	85	3,3	602	23,7	742,1	1

Height 85 mm
Nominal 3 3/8 inches

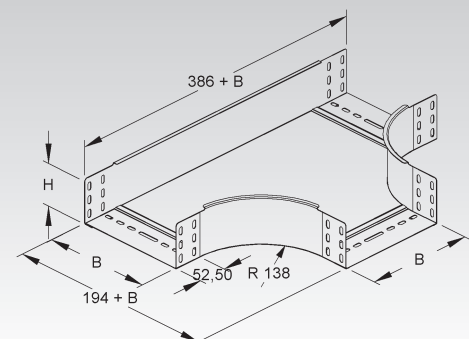

Horizontal Cross

with integrated splice

	model no.	height H		inside dimension (B)		Weight per 100 pcs kg	Pack/Box Qty
		mm	Inch	mm	Inch		
S	RKS 85.100	85	3,3	102	4	182,9	1
S	RKS 85.200	85	3,3	202	8	266,0	1
S	RKS 85.300	85	3,3	302	11,9	364,8	1
S	RKS 85.400	85	3,3	402	15,8	479,2	1
S	RKS 85.500	85	3,3	502	19,8	609,4	1
S	RKS 85.600	85	3,3	602	23,7	755,3	1
F	RKS 85.100 F	85	3,3	102	4	196,6	1
F	RKS 85.200 F	85	3,3	202	8	285,9	1
F	RKS 85.300 F	85	3,3	302	11,9	392,1	1
F	RKS 85.400 F	85	3,3	402	15,8	515,2	1
F	RKS 85.500 F	85	3,3	502	19,8	655,1	1
F	RKS 85.600 F	85	3,3	602	23,7	811,9	1

Height 85 mm
Nominal 3 3/8 inches

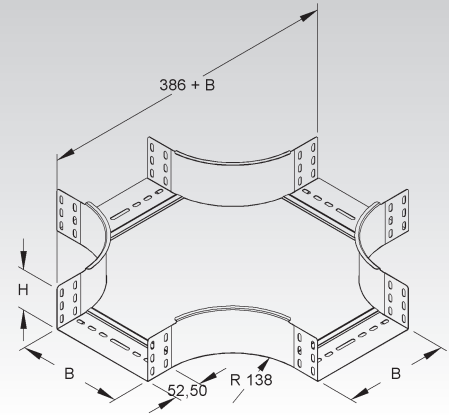

Reducer/Blind End

	model no.	height H		width B		width B1		Weight per 100 pcs kg	Pack/Box Qty
		mm	Inch	mm	Inch	mm	Inch		
S	RA 85.200	85	3,3	200	7,9	322	12,7	25,00	20
S	RA 85.400	85	3,3	400	15,7	522	20,6	42,00	20
S	RA 85.500	85	3,3	500	19,7	622	24,5	50,00	20
S	RA 85.600	85	3,3	600	23,6	722	28,4	59,00	20
F	RA 85.200 F	85	3,3	200	7,9	322	12,7	25,00	1
F	RA 85.400 F	85	3,3	400	15,7	522	20,6	42,00	1
F	RA 85.500 F	85	3,3	500	19,7	622	24,5	59,14	1
F	RA 85.600 F	85	3,3	600	23,6	722	28,4	59,00	1

Height 85 mm
Nominal 3 3/8 inches

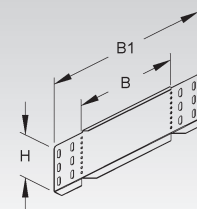

can be used as blind end or as reducer for cable tray

Adjustable Horizontal Splice/Reducer/Blind End

	model no.	height H		width B		width B1		Weight per 100 pcs kg	Pack/Box Qty
		mm	Inch	mm	Inch	mm	Inch		
S	RAW 85.100	85	3,3	100	3,9	222	8,7	28,23	20
S	RAW 85.300	85	3,3	300	11,8	422	16,6	33,00	20
F	RAW 85.100 F	85	3,3	100	3,9	222	8,7	30,98	1
F	RAW 85.300 F	85	3,3	300	11,8	422	16,6	33,00	1

Height 85 mm
Nominal 3 3/8 inches

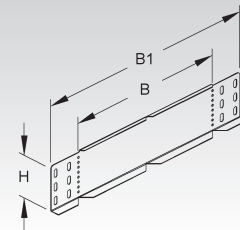

can be used as blind end or as reducer for cable tray

Adjustable Vertical Splice Plate

	model no.	height H		Weight per 100 pcs kg	Pack/Box Qty
		mm	Inch		
S	RGV 85	73	2,9	29,63	25
F	RGV 85 F	73	2,9	32,02	25

Height 85 mm
Nominal 3 3/8 inches

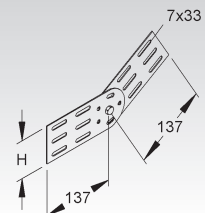

2 pieces required per joint

CABLE TRAY SYSTEM

Splice/Link Kit

	model no.	height H		width B		Weight per 100 pcs kg	Pack/Box Qty
		mm	Inch	mm	Inch		
S	RGE 85.100	85	3,3	100	3,9	78,59	1
S	RGE 85.200	85	3,3	200	7,9	88,87	1
S	RGE 85.300	85	3,3	300	11,8	99,15	1
S	RGE 85.400	85	3,3	400	15,7	109,43	1
S	RGE 85.500	85	3,3	500	19,7	119,71	1
S	RGE 85.600	85	3,3	600	23,6	129,99	1
F	RGE 85.100 F	85	3,3	100	3,9	86,11	1
F	RGE 85.200 F	85	3,3	200	7,9	97,41	1
F	RGE 85.300 F	85	3,3	300	11,8	108,72	1
F	RGE 85.400 F	85	3,3	400	15,7	120,03	1
F	RGE 85.500 F	85	3,3	500	19,7	131,34	1
F	RGE 85.600 F	85	3,3	600	23,6	142,65	1

for linking sections of tray with a vertical displacement

Height 85 mm
Nominal 3 3/8 inches

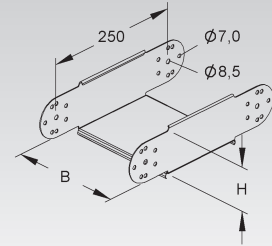

Vertical Inside Elbow 90°

with integrated splice

	model no.	height H		inside dimension (B)		Weight per 100 pcs kg	Pack/Box Qty
		mm	Inch	mm	Inch		
S	RSD 85.100	85	3,3	102	4	90,07	1
S	RSD 85.200	85	3,3	202	8	125,37	1
S	RSD 85.300	85	3,3	302	11,9	159,75	1
S	RSD 85.400	85	3,3	402	15,8	195,05	1
S	RSD 85.500	85	3,3	502	19,8	229,43	1
S	RSD 85.600	85	3,3	602	23,7	263,81	1

Height 85 mm
Nominal 3 3/8 inches

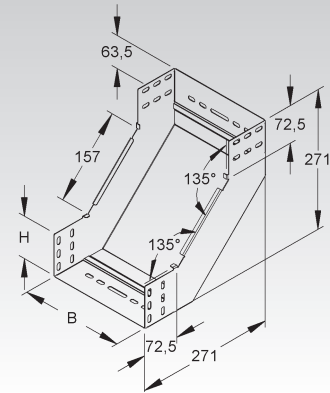

Vertical Outside Elbow 90°

with integrated splice

	model no.	height H		inside dimension (B)		Weight per 100 pcs kg	Pack/Box Qty
		mm	Inch	mm	Inch		
S	RFD 85.100	85	3,3	102	4	88,63	1
S	RFD 85.200	85	3,3	202	8	116,15	1
S	RFD 85.300	85	3,3	302	11,9	142,87	1
S	RFD 85.400	85	3,3	402	15,8	170,40	1
S	RFD 85.500	85	3,3	502	19,8	197,12	1
S	RFD 85.600	85	3,3	602	23,7	223,84	1

Height 85 mm
Nominal 3 3/8 inches

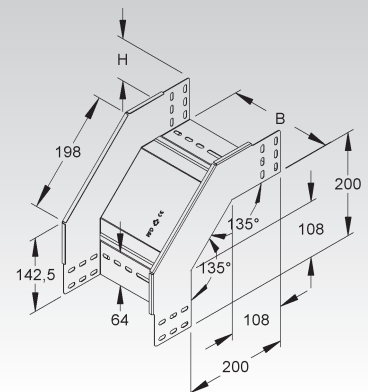

Vertical Tee Down, lengthwise

with integrated splice

	model no.	height H		width B		length A		Weight per 100 pcs kg	Pack/Box Qty
		mm	Inch	mm	Inch	mm	Inch		
S	RTL 85.100	85	3,3	100	3,9	201	7,9	137	1
S	RTL 85.200	85	3,3	200	7,9	401	15,8	244	1
S	RTL 85.300	85	3,3	300	11,8	701	27,6	493	1
S	RTL 85.400	85	3,3	400	15,7	801	31,5	614	1
S	RTL 85.500	85	3,3	500	19,7	901	35,5	750	1
S	RTL 85.600	85	3,3	600	23,6	1001	39,4	903	1

Size of run and tap tray is identical.

▲ Height
85 mm
▼

Nominal
3 3/8
inches

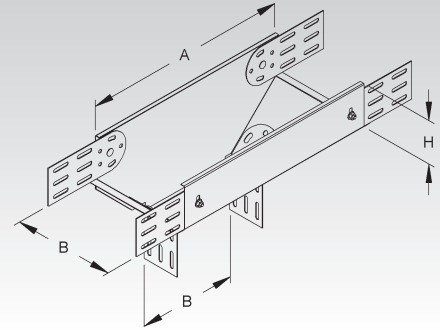

Vertical Tee Down, crosswise

with integrated splice

	model no.	height H		inside dimension (B)		length A		Weight per 100 pcs kg	Pack/Box Qty
		mm	Inch	mm	Inch	mm	Inch		
S	RTQ 85.100	85	3,3	102	4	336	13,2	122,19	1
S	RTQ 85.200	85	3,3	202	8	336	13,2	158,35	1
S	RTQ 85.300	85	3,3	302	11,9	336	13,2	192,91	1
S	RTQ 85.400	85	3,3	402	15,8	336	13,2	229,07	1
S	RTQ 85.500	85	3,3	502	19,8	336	13,2	263,63	1
S	RTQ 85.600	85	3,3	602	23,7	336	13,2	298,19	1

Size of run and tap tray is identical.

▲ Height
85 mm
▼

Nominal
3 3/8
inches

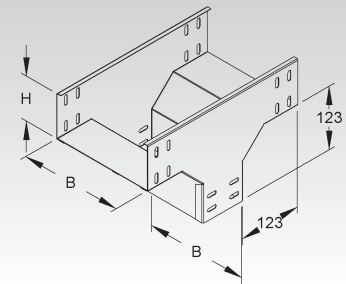

Edge Protection Plate

	model no.	width B		Weight per 100 pcs kg	Pack/Box Qty
		mm	Inch		
S	RKB 100	92	3,6	4,22	10
S	RKB 200	192	7,6	8,77	10
S	RKB 300	292	11,5	12,84	10
S	RKB 400	392	15,4	16,91	10
S	RKB 500	492	19,4	20,98	10
S	RKB 600	592	23,3	25,05	10
F	RKB 100 F	92	3,6	4,66	50
F	RKB 200 F	192	7,6	9,69	50
F	RKB 300 F	292	11,5	14,16	50
F	RKB 400 F	392	15,4	18,64	50
F	RKB 500 F	492	19,4	23,12	50
F	RKB 600 F	592	23,3	27,60	50

with rounded edges to protect cables at the joint and to reinforce the bottom of cable trays

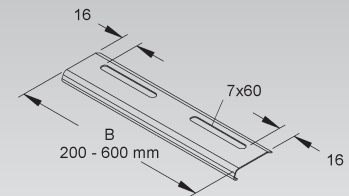

CABLE TRAY SYSTEM

Available Side Rail Heights

SYSTEM			
	Cable Tray	RL...	Page 201
	Cable Tray	RLU...	Page 201
	Heavy Duty Cable Tray	RS...	Page 202
	Heavy Duty Cable Tray	RSU...	Page 202
	Distribution Cable Tray	RSV...	Page 203
ZUBEHÖR	Edge Protection Ring	KSR 40 A	Page 203
	U-shaped Splice Plate	RV...	Page 204
	Splice Plate	RVV 110 E3	Page 204
	★ Universal Splice Plate	RSUV 110-1.5/200 S	Page 205
	Barrier Strip	RW 110...	Page 205
	Splice Plate for Barrier Strip	RTV 110 E2	Page 205
	Mounting Plate for Barrier Strip	RTPH 50+M6	Page 205/206
	Extension Horizontal Tee	RTA...	Page 206
	Horizontal Elbow Building Block	REK...	Page 206
	Flexible Horizontal Elbow 0-90°	RBAV...	Page 207
	Horizontal Elbow 45°	RBA...	Page 207
	Horizontal Elbow 90°	RES...	Page 207
	Horizontal Tee	RTS...	Page 208
	Horizontal Cross	RKS...	Page 208
	Reducer/Blind End	RA...	Page 208
	Adjustable Horizontal Splice/Reducer/Blind End	RAW...	Page 209
	Adjustable Vertical Splice Plate	RGV...	Page 209
	Splice/Link Kit	RGE...	Page 209
	Vertical Inside Elbow 45°	RSB...	Page 209
	Vertical Inside Elbow 90°	RSD...	Page 210
	Vertical Outside Elbow 45°	RFB...	Page 210
	Vertical Outside Elbow 90°	RFD...	Page 210
	Vertical Tee Down, lengthwise	RTL...	Page 211
	Vertical Tee Down, crosswise	RTQ...	Page 211
	Edge Protection Plate	RKB...	Page 211

See covers for cable trays and fittings on page 212 and following.



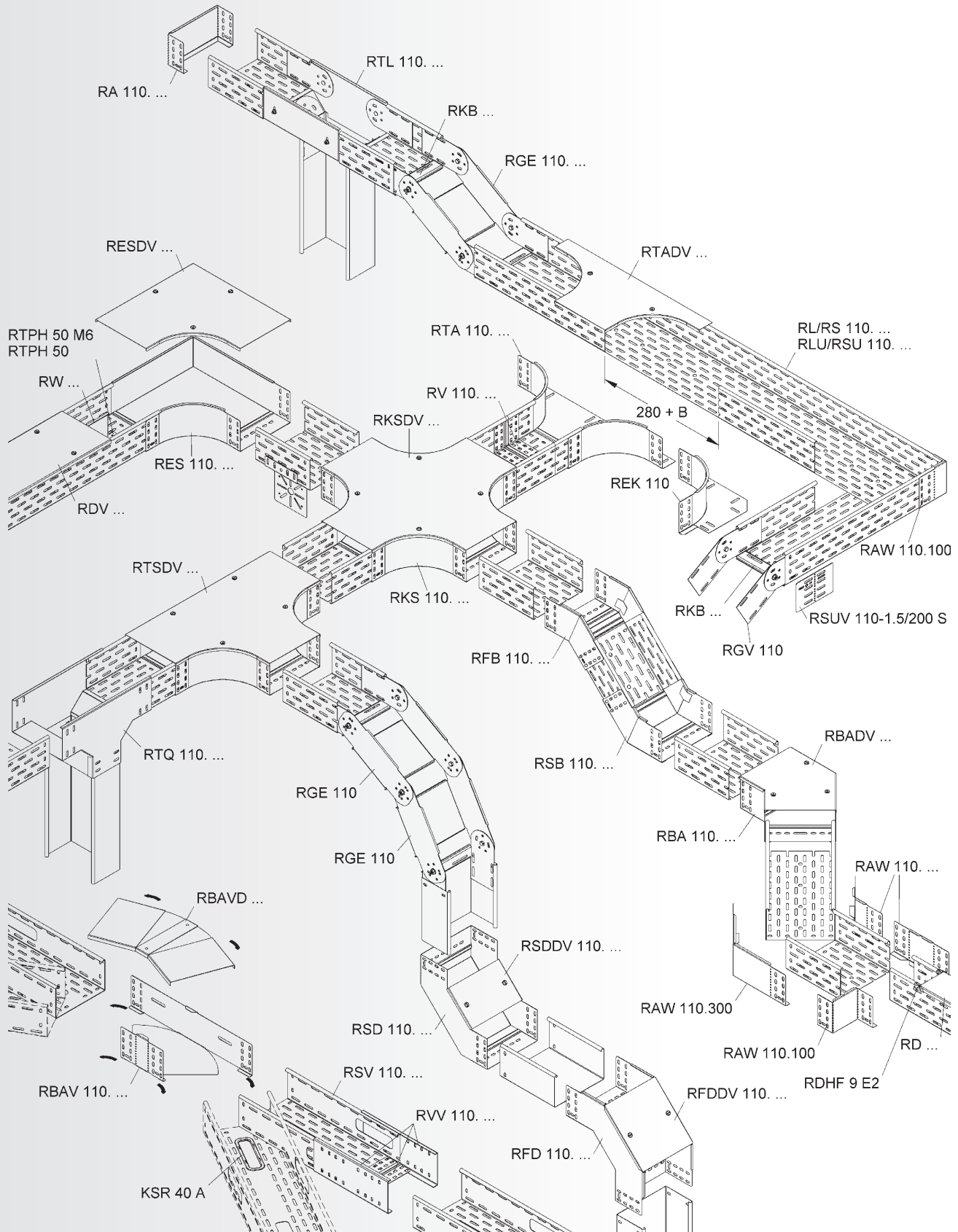

CABLE TRAY SYSTEM

➔ Load/Span Class Designation in accordance with NEMA VE 1 and CSA E22.2 No. 126.1

Niedax Series	Minimum Area		Load class in accordance to NEMA VE 1		
	(calculational) mm ² / in. ²	in accordance to NEMA VE 2 mm ² / in. ²	Rated Load Kg/m / lb./ft.	Support spacing m / ft.	Load/Span Class
RLX 110.100, ... F	234 / 0.36	129 / 0.2	113 / 76	2 / 6.6	8A, A
RLX 110.200, ... F	332 / 0.51	258 / 0.4	113 / 76	2 / 6.6	8A, A
RLX 110.300, ... F	404 / 0.63	258 / 0.4	113 / 76	2 / 6.6	8A, A
RLX 110.400, ... F	476 / 0.74	452 / 0.7	113 / 76	2 / 6.6	8A, A
RLX 110.500, ... F	548 / 0.85	452 / 0.7	113 / 76	2 / 6.6	8A, A
RLX 110.600, ... F	620 / 0.96	452 / 0.7	113 / 76	2 / 6.6	8A, A
RLX 110.100 E3	208 / 0.32	129 / 0.2	113 / 76	2 / 6.6	8A, A
RLX 110.200 E3	266 / 0.41	258 / 0.4	113 / 76	2 / 6.6	8A, A
RLX 110.300 E3	323 / 0.50	258 / 0.4	113 / 76	2 / 6.6	8A, A
RLX 110.400 E3	428 / 0.66	258 / 0.4	113 / 76	2 / 6.6	8A, A
RLX 110.500 E3	493 / 0.76	452 / 0.7	113 / 76	2 / 6.6	8A, A
RLX 110.600 E3	558 / 0.86	452 / 0.7	113 / 76	2 / 6.6	8A, A
RLUX 110.100, ... F	310 / 0.48	258 / 0.4	113 / 76	2 / 6.6	8A, A
RLUX 110.200, ... F	444 / 0.69	258 / 0.4	113 / 76	2 / 6.6	8A, A
RLUX 110.300, ... F	544 / 0.84	452 / 0.7	113 / 76	2 / 6.6	8A, A
RLUX 110.400, ... F	644 / 1.00	645 / 1.0	113 / 76	2 / 6.6	8A, A
RLUX 110.500, ... F	744 / 1.15	645 / 1.0	113 / 76	2 / 6.6	8A, A
RLUX 110.600, ... F	844 / 1.31	645 / 1.0	113 / 76	2 / 6.6	8A, A
RLUX 110.100 E3	275 / 0.43	258 / 0.4	113 / 76	2 / 6.6	8A, A
RLUX 110.200 E3	355 / 0.55	258 / 0.4	113 / 76	2 / 6.6	8A, A
RLUX 110.300 E3	435 / 0.67	258 / 0.4	113 / 76	2 / 6.6	8A, A
RLUX 110.400 E3	580 / 0.90	452 / 0.7	113 / 76	2 / 6.6	8A, A
RLUX 110.500 E3	670 / 1.04	645 / 1.0	113 / 76	2 / 6.6	8A, A
RLUX 110.600 E3	760 / 1.18	645 / 1.0	113 / 76	2 / 6.6	8A, A
RSX 110.100, ... F	386 / 0.60	258 / 0.4	224 / 151	2 / 6.6	8A, 8B, 8C, A, C
RSX 110.200, ... F	494 / 0.77	452 / 0.7	224 / 151	2 / 6.6	8A, 8B, 8C, A, C
RSX 110.300, ... F	602 / 0.93	452 / 0.7	224 / 151	2 / 6.6	8A, 8B, 8C, A, C
RSX 110.400, ... F	710 / 1.10	645 / 1.0	224 / 151	2 / 6.6	8A, 8B, 8C, A, C
RSX 110.500, ... F	818 / 1.27	645 / 1.0	224 / 151	2 / 6.6	8A, 8B, 8C, A, C
RSX 110.600, ... F	930 / 1.44	645 / 1.0	224 / 151	2 / 6.6	8A, 8B, 8C, A, C
RSUX 110.100, ... F	512 / 0.79	452 / 0.7	224 / 151	2 / 6.6	8A, 8B, 8C, A, C
RSUX 110.200, ... F	662 / 1.03	645 / 1.0	224 / 151	2 / 6.6	8A, 8B, 8C, A, C
RSUX 110.300, ... F	812 / 1.26	645 / 1.0	224 / 151	2 / 6.6	8A, 8B, 8C, A, C
RSUX 110.400, ... F	961 / 1.49	645 / 1.0	224 / 151	2 / 6.6	8A, 8B, 8C, A, C
RSUX 110.500, ... F	1112 / 1.72	968 / 1.5	224 / 151	2 / 6.6	8A, 8B, 8C, A, C
RSUX 110.600, ... F	1266 / 1.96	968 / 1.5	224 / 151	2 / 6.6	8A, 8B, 8C, A, C
RSVX 110.100 S, ... F *	368 / 0.57	258 / 0.4	67 / 45	3 / 9.8	8A, A
RSVX 110.150 S, ... F *	383 / 0.59	258 / 0.4	67 / 45	3 / 9.8	8A, A
RSVX 110.200 S, ... F *	437 / 0.68	258 / 0.4	67 / 45	3 / 9.8	8A, A
RSVX 110.300 S, ... F *	587 / 0.91	452 / 0.7	67 / 45	3 / 9.8	8A, A
RSVX 110.400 S, ... F *	758 / 1.17	645 / 1.0	67 / 45	3 / 9.8	8A, A

* - tested by UL with the three piece splice plate kit RVVX in the middle of two supports



Cable Tray

ventilated

	model no.	height H		width B		thick-ness t mm	Weight per 100 m/kg	Pack/Box Qty
		mm Inch	mm Inch	mm Inch	mm Inch			
S	RL 110.100	110 4,3	100 3,9	0,9	216,07	2 x 3 m		
S	RL 110.200	110 4,3	200 7,9	1,0	306,77	2 x 3 m		
S	RL 110.300	110 4,3	300 11,8	1,0	374,30	2 x 3 m		
S	RL 110.400	110 4,3	400 15,7	1,0	442,36	2 x 3 m		
S	RL 110.500	110 4,3	500 19,7	1,0	509,90	2 x 3 m		
S	RL 110.600	110 4,3	600 23,6	1,0	577,95	2 x 3 m		
F	RL 110.100 F	110 4,3	100 3,9	0,9	237,72	2 x 3 m		
F	RL 110.200 F	110 4,3	200 7,9	1,0	337,50	2 x 3 m		
F	RL 110.300 F	110 4,3	300 11,8	1,0	411,79	2 x 3 m		
F	RL 110.400 F	110 4,3	400 15,7	1,0	486,68	2 x 3 m		
F	RL 110.500 F	110 4,3	500 19,7	1,0	560,97	2 x 3 m		
F	RL 110.600 F	110 4,3	600 23,6	1,0	637,29	2 x 3 m		
E3	RL 110.100 E3	110 4,3	100 3,9	0,8	194,84	2 x 3 m		
E3	RL 110.200 E3	110 4,3	200 7,9	0,8	250,24	2 x 3 m		
E3	RL 110.300 E3	110 4,3	300 11,8	0,8	305,03	2 x 3 m		
E3	RL 110.400 E3	110 4,3	400 15,7	0,9	403,05	2 x 3 m		
E3	RL 110.500 E3	110 4,3	500 19,7	0,9	464,43	2 x 3 m		
E3	RL 110.600 E3	110 4,3	600 23,6	0,9	525,83	2 x 3 m		

Centered punchholes allow hanging with M10 (3/8") threaded rod.

One RV... splice plate included with every piece of cable tray.

Load Chart: q = uniformly distributed load (tested according to DIN EN IEC 61537 standard)

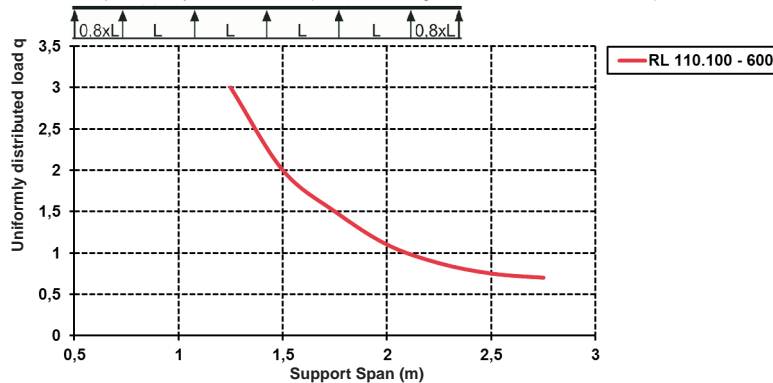

Height 110 mm
Nominal 4 3/8 inches

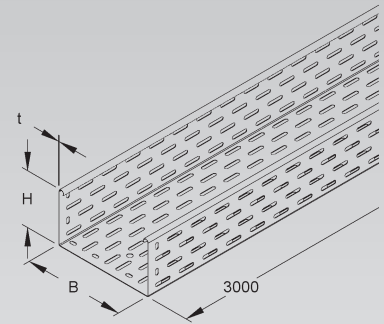

Cable Tray

solid, but with splice plate perforation

	model no.	height H		width B		thick-ness t mm	Weight per 100 m/kg	Pack/Box Qty
		mm Inch	mm Inch	mm Inch	mm Inch			
S	RLU 110.100	110 4,3	100 3,9	0,9	251,65	2 x 3 m		
S	RLU 110.200	110 4,3	200 7,9	1,0	359,32	2 x 3 m		
S	RLU 110.300	110 4,3	300 11,8	1,0	439,82	2 x 3 m		
S	RLU 110.400	110 4,3	400 15,7	1,0	520,85	2 x 3 m		
S	RLU 110.500	110 4,3	500 19,7	1,0	601,39	2 x 3 m		
S	RLU 110.600	110 4,3	600 23,6	1,0	683,01	2 x 3 m		
F	RLU 110.100 F	110 4,3	100 3,9	0,9	276,86	2 x 3 m		
F	RLU 110.200 F	110 4,3	200 7,9	1,0	394,70	2 x 3 m		
F	RLU 110.300 F	110 4,3	300 11,8	1,0	483,88	2 x 3 m		
F	RLU 110.400 F	110 4,3	400 15,7	1,0	573,01	2 x 3 m		
F	RLU 110.500 F	110 4,3	500 19,7	1,0	661,62	2 x 3 m		
F	RLU 110.600 F	110 4,3	600 23,6	1,0	751,42	2 x 3 m		
E3	RLU 110.100 E3	110 4,3	100 3,9	0,8	226,68	2 x 3 m		
E3	RLU 110.200 E3	110 4,3	200 7,9	0,8	292,55	2 x 3 m		
E3	RLU 110.300 E3	110 4,3	300 11,8	0,8	357,77	2 x 3 m		
E3	RLU 110.400 E3	110 4,3	400 15,7	0,9	474,14	2 x 3 m		
E3	RLU 110.500 E3	110 4,3	500 19,7	0,9	547,30	2 x 3 m		
E3	RLU 110.600 E3	110 4,3	600 23,6	0,9	620,57	2 x 3 m		

Height 110 mm
Nominal 4 3/8 inches

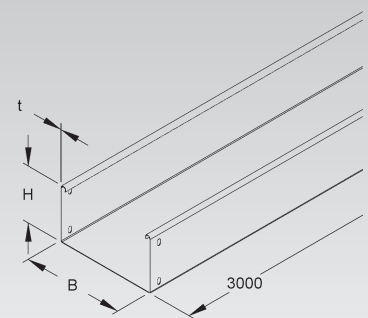

One RV... splice plate included with every piece of cable tray.

CABLE TRAY SYSTEM

Heavy Duty Cable Tray

ventilated

	model no.	height H		width B		thick-ness t	Weight per 100 m/ kg	Pack/ Box Qty
		mm Inch	mm Inch	mm	mm			
S	RS 110.100	110 4,3	100 3,9	1,5	350,00	2 x 3 m		
S	RS 110.200	110 4,3	200 7,9	1,5	450,00	2 x 3 m		
S	RS 110.300	110 4,3	300 11,8	1,5	551,43	2 x 3 m		
S	RS 110.400	110 4,3	400 15,7	1,5	651,87	2 x 3 m		
S	RS 110.500	110 4,3	500 19,7	1,5	810,00	2 x 3 m		
S	RS 110.600	110 4,3	600 23,6	1,5	854,12	2 x 3 m		
F	RS 110.100 F	110 4,3	100 3,9	1,5	350,00	2 x 3 m		
F	RS 110.200 F	110 4,3	200 7,9	1,5	450,00	2 x 3 m		
F	RS 110.300 F	110 4,3	300 11,8	1,5	564,00	2 x 3 m		
F	RS 110.400 F	110 4,3	400 15,7	1,5	717,13	2 x 3 m		
F	RS 110.500 F	110 4,3	500 19,7	1,5	810,00	2 x 3 m		
F	RS 110.600 F	110 4,3	600 23,6	1,5	937,75	2 x 3 m		

Centered punchholes allow hanging with M10 (3/8") threaded rod. Bottom plate and side rail perforated with staggered punch holes. Extra 7/16" punch holes (11 mm) for center hanging with threaded rod.

One RV... splice plate included with every piece of cable tray.

Load Chart: q = uniformly distributed load (tested according to DIN EN IEC 61537 standard)

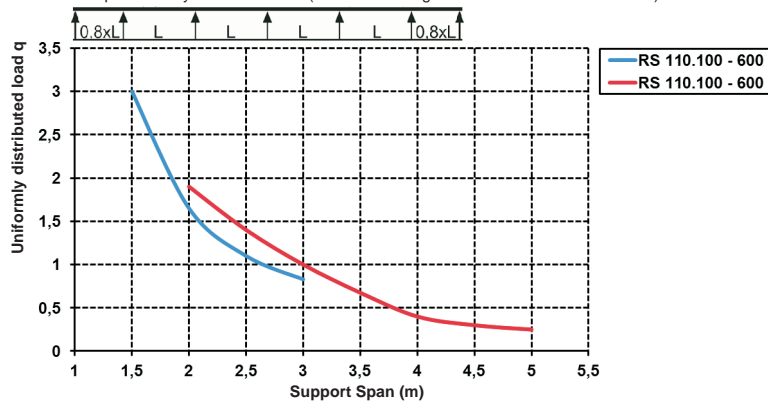

Load rating with heavy duty splice plate RVV... in red.

Height 110 mm
Nominal 4 3/8 inches

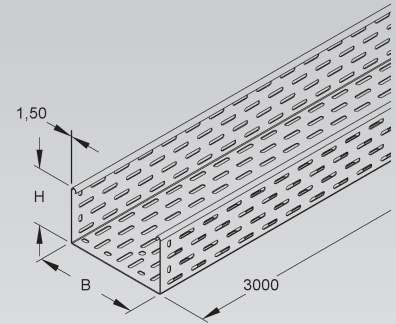

Heavy Duty Cable Tray

solid, but with splice plate perforation

	model no.	height H		width B		thick-ness t	Weight per 100 m/ kg	Pack/ Box Qty
		mm Inch	mm Inch	mm	mm			
S	RSU 110.100	110 4,3	100 3,9	1,5	409,65	2 x 3 m		
S	RSU 110.200	110 4,3	200 7,9	1,5	529,99	2 x 3 m		
S	RSU 110.300	110 4,3	300 11,8	1,5	649,72	2 x 3 m		
S	RSU 110.400	110 4,3	400 15,7	1,5	769,99	2 x 3 m		
S	RSU 110.500	110 4,3	500 19,7	1,5	889,79	2 x 3 m		
S	RSU 110.600	110 4,3	600 23,6	1,5	1.010,04	2 x 3 m		
F	RSU 110.100 F	110 4,3	100 3,9	1,5	450,63	2 x 3 m		
F	RSU 110.200 F	110 4,3	200 7,9	1,5	583,01	2 x 3 m		
F	RSU 110.300 F	110 4,3	300 11,8	1,5	714,76	2 x 3 m		
F	RSU 110.400 F	110 4,3	400 15,7	1,5	847,03	2 x 3 m		
F	RSU 110.500 F	110 4,3	500 19,7	1,5	978,81	2 x 3 m		
F	RSU 110.600 F	110 4,3	600 23,6	1,5	1.111,18	2 x 3 m		

One RV... splice plate included with every piece of cable tray.

Height 110 mm
Nominal 4 3/8 inches

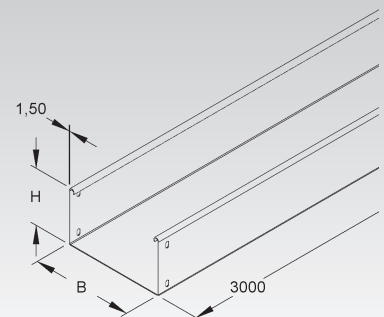

Distribution Cable Tray

ventilated

	model no.	height H		width B		thick-ness t	Weight per 100 m	Pack/Box Qty
		mm	Inch	mm	Inch			
S	RSV 110.100 S	110	4,3	100	3,9	1,5	333,62	2 x 3 m
S	RSV 110.150 S	110	4,3	150	5,9	1,5	383,76	2 x 3 m
S	RSV 110.200 S	110	4,3	200	7,9	1,5	433,91	2 x 3 m
S	RSV 110.300 S	110	4,3	300	11,8	1,5	537,44	2 x 3 m
S	RSV 110.400 S	110	4,3	400	15,7	1,5	647,42	2 x 3 m
F	RSV 110.100 F	110	4,3	100	3,9	1,5	366,66	2 x 3 m
F	RSV 110.150 F	110	4,3	150	5,9	1,5	421,82	2 x 3 m
F	RSV 110.200 F	110	4,3	200	7,9	1,5	476,98	2 x 3 m
F	RSV 110.300 F	110	4,3	300	11,8	1,5	590,86	2 x 3 m
F	RSV 110.400 F	110	4,3	400	15,7	1,5	711,84	2 x 3 m

Hole pattern may vary based on width of tray.

Multiple cable drop outs are punched into the bottom part and the flange of tray.

One RV... splice plate included with every piece of cable tray.

Load Chart: q = uniformly distributed load (tested according to DIN EN IEC 61537 standard)

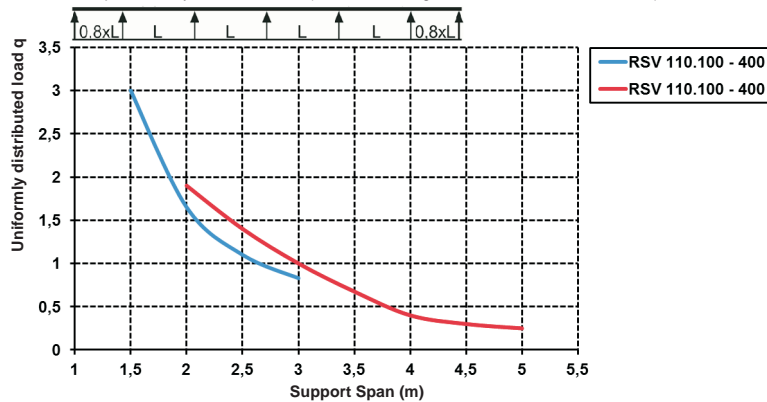

Load rating with heavy duty splice plate RVV... in red.

Height 110 mm
Nominal 4 3/8 inches
50

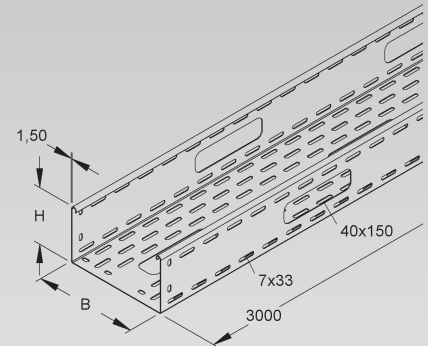

Edge Protection Ring

UV resistant

	model no.	color	inside height H		inside dimension (B)		Weight per 100 pcs	Pack/Box Qty
			mm	Inch	mm	Inch		
K04	KSR 40 A	black	34,5	1,4	144,5	5,7	0,97	20

to protect cables at the knockouts of tray or surface metal raceways

Suitable for: RLCPV 85... OV and RSV 110... distribution cable tray

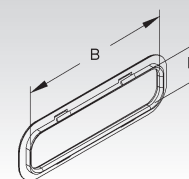

CABLE TRAY SYSTEM

U-shaped Splice Plate

model no.		height H	width B	Weight per 100 pcs./pc./ kg	Pack/ Box Qty
		mm Inch	mm Inch		
S	RV 110.100	99 3,9	97 3,8	23,77	1
S	RV 110.150	99 3,9	147 5,8	26,84	1
S	RV 110.200	99 3,9	197 7,8	31,51	1
S	RV 110.300	99 3,9	297 11,7	37,65	1
S	RV 110.400	99 3,9	397 15,6	45,38	1
S	RV 110.500	99 3,9	497 19,6	51,52	1
S	RV 110.600	99 3,9	597 23,5	62,77	1
F	RV 110.100 F	99 3,9	97 3,8	26,31	1
F	RV 110.150 F	99 3,9	147 5,8	29,68	1
F	RV 110.200 F	99 3,9	197 7,8	34,86	1
F	RV 110.300 F	99 3,9	297 11,7	41,62	1
F	RV 110.400 F	99 3,9	397 15,6	50,16	1
F	RV 110.500 F	99 3,9	497 19,6	56,91	1
F	RV 110.600 F	99 3,9	597 23,5	67,26	1
E3	RV 110.100 E3	99 3,9	97 3,8	24,76	1
E3	RV 110.200 E3	99 3,9	197 7,8	32,76	1
E3	RV 110.300 E3	99 3,9	297 11,7	38,94	1
E3	RV 110.400 E3	99 3,9	397 15,6	46,93	1
E3	RV 110.500 E3	99 3,9	497 19,6	53,11	1
E3	RV 110.600 E3	99 3,9	597 23,5	59,52	1

Height 110 mm
Nominal 4 3/8 inches

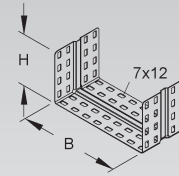

Suitable for: RL/RS... cable trays

Three Piece Splice Plate Kit

model no.		height H	width B	Weight per 100 pcs./pc./ kg	Pack/ Box Qty
		mm Inch	mm Inch		
S	RVV 110.100	111 4,4	100 3,9	112,36	5
S	RVV 110.150	111 4,4	150 5,9	115,83	5
S	RVV 110.200	111 4,4	200 7,9	119,30	5
S	RVV 110.300	111 4,4	300 11,8	126,24	5
S	RVV 110.400	111 4,4	400 15,7	133,18	5
S	RVV 110.500	111 4,4	500 19,7	140,12	5
S	RVV 110.600	111 4,4	600 23,6	147,06	5
F	RVV 110.100 F	111 4,4	100 3,9	124,14	5
F	RVV 110.150 F	111 4,4	150 5,9	127,95	5
F	RVV 110.200 F	111 4,4	200 7,9	131,77	5
F	RVV 110.300 F	111 4,4	300 11,8	139,40	5
F	RVV 110.400 F	111 4,4	400 15,7	147,04	5
F	RVV 110.500 F	111 4,4	500 19,7	154,67	5
F	RVV 110.600 F	111 4,4	600 23,6	162,31	5

Height 110 mm
Nominal 4 3/8 inches

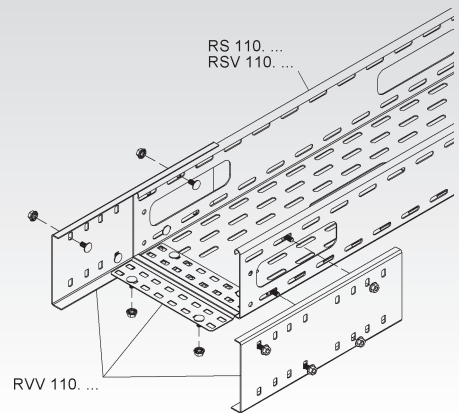
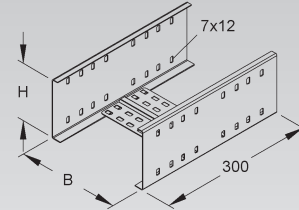

heavy duty splice kit to extend support span

Suitable for: extending support span of RS/RSV 110... tray up to 5 meters

Splice Plate

model no.		height H	Weight per 100 pcs kg	Pack/ Box Qty
		mm Inch		
E3	RVV 110 E3	111 4,4	51,01	10

Height 110 mm
Nominal 4 3/8 inches

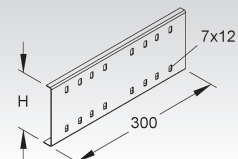

heavy duty splice kit to extend support span

2 pieces required per joint



Universal Splice Plate

model no.	height H	width B	thick- ness t	Weight per 100	Pack/ Box Qty
	mm Inch	mm Inch	mm	kg	
S RSUV 110-1.5/200 S	102 4	200 7,9	1,5	23,26	50

for straight and angled joints

Height 110 mm
Nominal 4 3/8 inches
62

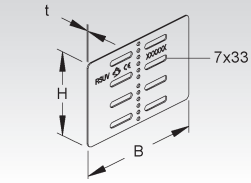

Barrier Strip

model no.	height H	thick- ness t	Weight per 100 m	Pack/ Box Qty
	mm Inch	mm	kg	
S RW 110	98 3,9	0,9	90,37	10 x 3 m
F RW 110 F	98 3,9	0,9	99,30	10 x 3 m
E3 RW 110 E3	98 3,9	0,9	90,94	10 x 3 m

to separate wires and cables of different voltage levels or with different functions

Height 110 mm
Nominal 4 3/8 inches
61

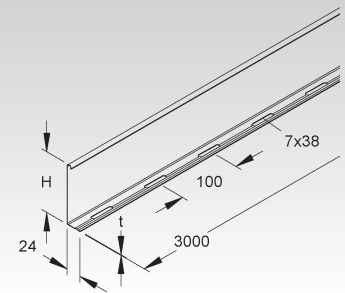

Splice Plate for Barrier Strip

model no.	height H	length A	Weight per 100 pcs	Pack/ Box Qty
	mm Inch	mm Inch	kg	
E2 RTV 110 E2	97,5 3,8	80 3,1	2,5	20

for positive locking connections and proper bonding of barrier strips

Height 110 mm
Nominal 4 3/8 inches
61

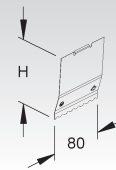

Mounting Plate for Barrier Strip

model no.	length A	width B	thick- ness t	Weight per 100 pcs	Pack/ Box Qty
	mm Inch	mm Inch	mm	kg	
S RTPH 50	83 3,3	59 2,3	0,9	3,36	20

Mounting plate with latching mechanism for fast installation of barrier strips in ventilated RL/RS series cable trays.

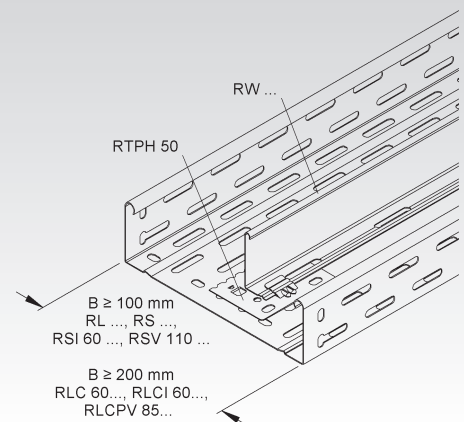
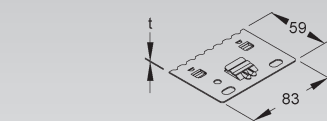

CABLE TRAY SYSTEM

Mounting Plate for Barrier Strip with M6 Stud

model no.	length A		width B		thick- ness t mm	Weight per 100 pcs kg	Pack/ Box Qty
	mm	Inch	mm	Inch			
S RTPH 50 M6	83	3,3	59	2,3	0,9	3,98	50

Mounting plate with latching mechanism for fast installation of barrier strips in ventilated RL/RS series cable trays. With M6 locking stud.

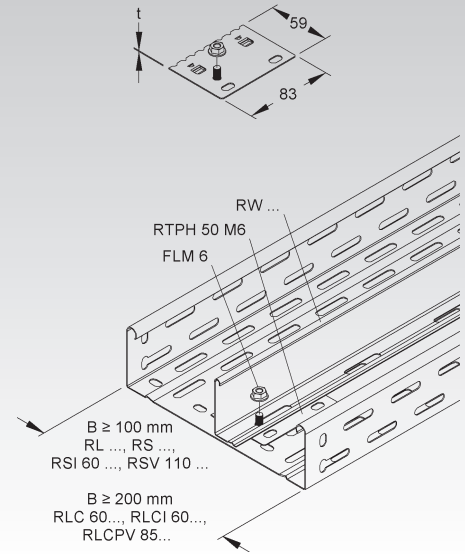

Extension Horizontal Tee

with integrated splice

model no.	height H	inside dimension (B)		Weight per 100 pcs/pc./ kg	Pack/ Box Qty	
		mm	Inch			
S RTA 110.100	110	4,3	102	4	106,56	1
S RTA 110.150	110	4,3	152	6	115,02	1
S RTA 110.200	110	4,3	202	8	123,48	1
S RTA 110.300	110	4,3	302	11,9	140,40	1
S RTA 110.400	110	4,3	402	15,8	157,60	1
S RTA 110.500	110	4,3	502	19,8	174,06	1
S RTA 110.600	110	4,3	602	23,7	190,98	1
F RTA 110.100 F	110	4,3	102	4	117,42	1
F RTA 110.150 F	110	4,3	152	6	126,72	1
F RTA 110.200 F	110	4,3	202	8	136,03	1
F RTA 110.300 F	110	4,3	302	11,9	154,64	1
F RTA 110.400 F	110	4,3	402	15,8	173,56	1
F RTA 110.500 F	110	4,3	502	19,8	191,67	1
F RTA 110.600 F	110	4,3	602	23,7	211,85	1
E3 RTA 110.100 E3	110	4,3	102	4	98,05	1
E3 RTA 110.200 E3	110	4,3	202	8	113,14	1
E3 RTA 110.300 E3	110	4,3	302	11,9	128,28	1
E3 RTA 110.400 E3	110	4,3	402	15,8	162,95	1
E3 RTA 110.500 E3	110	4,3	502	19,8	181,42	1
E3 RTA 110.600 E3	110	4,3	602	23,7	200,54	1

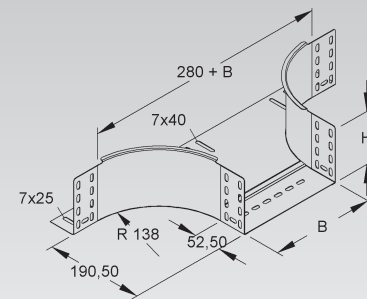

Horizontal Elbow Building Block

with integrated splice

model no.	height H	Weight per 100 pcs kg	Pack/ Box Qty	
				mm
S REK 110	110	4,3	51,84	1
F REK 110 F	110	4,3	57,14	1
E3 REK 110 E3	110	4,3	47,88	1

for building customized horizontal cable tray fittings

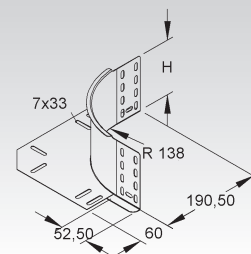

Flexible Horizontal Elbow 0-90°

with integrated splice

	model no.	height H		inside dimension (B)		Weight per 100 pcs./pc./ kg	Pack/ Box Qty
		mm	Inch	mm	Inch		
S	RBAV 110.100	110	4,3	100	3,9	63,79	1
S	RBAV 110.150	110	4,3	150	5,9	80,92	1
S	RBAV 110.200	110	4,3	200	7,9	98,85	1
S	RBAV 110.300	110	4,3	300	11,8	147,40	1
S	RBAV 110.400	110	4,3	400	15,7	205,26	1
S	RBAV 110.500	110	4,3	500	19,7	282,04	1
S	RBAV 110.600	110	4,3	600	23,6	366,80	1

Height
110 mm
Nominal
4 3/8 inches

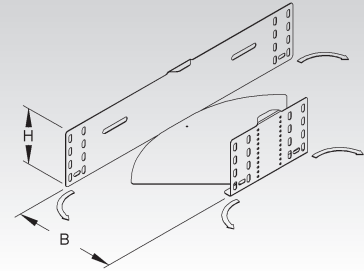

Horizontal Elbow 45°

with integrated splice

	model no.	height H		inside dimension (B)		Weight per 100 pcs./pc./ kg	Pack/ Box Qty
		mm	Inch	mm	Inch		
S	RBA 110.100	110	4,3	102	4	63,30	1
S	RBA 110.150	110	4,3	152	6	79,30	1
S	RBA 110.200	110	4,3	202	8	96,90	1
S	RBA 110.300	110	4,3	302	11,9	137,00	1
S	RBA 110.400	110	4,3	402	15,8	183,80	1
S	RBA 110.500	110	4,3	502	19,8	236,90	1
S	RBA 110.600	110	4,3	602	23,7	300,12	1
F	RBA 110.100 F	110	4,3	102	4	72,94	1
F	RBA 110.150 F	110	4,3	152	6	85,20	1
F	RBA 110.200 F	110	4,3	202	8	111,33	1
F	RBA 110.300 F	110	4,3	302	11,9	155,18	1
F	RBA 110.400 F	110	4,3	402	15,8	207,49	1
F	RBA 110.500 F	110	4,3	502	19,8	265,65	1
F	RBA 110.600 F	110	4,3	602	23,7	331,19	1

Height
110 mm
Nominal
4 3/8 inches

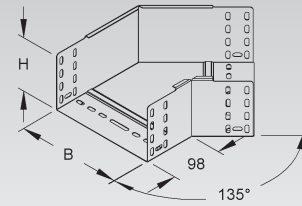

Horizontal Elbow 90°

with integrated splice

	model no.	height H		inside dimension (B)		Weight per 100 pcs./pc./ kg	Pack/ Box Qty
		mm	Inch	mm	Inch		
S	RES 110.100	110	4,3	102	4	130,87	1
S	RES 110.150	110	4,3	152	6	163,59	1
S	RES 110.200	110	4,3	202	8	210,10	1
S	RES 110.300	110	4,3	302	11,9	300,12	1
S	RES 110.400	110	4,3	402	15,8	406,21	1
S	RES 110.500	110	4,3	502	19,8	527,62	1
S	RES 110.600	110	4,3	602	23,7	664,74	1
F	RES 110.100 F	110	4,3	102	4	144,04	1
F	RES 110.150 F	110	4,3	152	6	180,03	1
F	RES 110.200 F	110	4,3	202	8	231,21	1
F	RES 110.300 F	110	4,3	302	11,9	330,23	1
F	RES 110.400 F	110	4,3	402	15,8	446,95	1
F	RES 110.500 F	110	4,3	502	19,8	580,50	1
F	RES 110.600 F	110	4,3	602	23,7	731,33	1

Height
110 mm
Nominal
4 3/8 inches

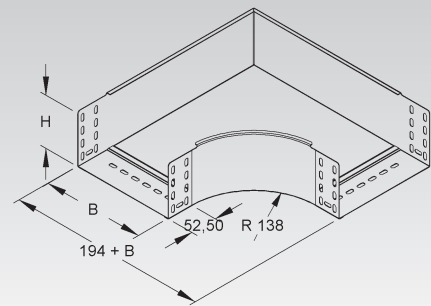

CABLE TRAY SYSTEM

Horizontal Tee

with integrated splice

	model no.	height H		inside dimension (B)		Weight per 100 pcs./pc./ kg	Pack/Box Qty
		mm	Inch	mm	Inch		
S	RTS 110.100	110	4,3	102	4	171,34	1
S	RTS 110.150	110	4,3	152	6	205,51	1
S	RTS 110.200	110	4,3	202	8	257,52	1
S	RTS 110.300	110	4,3	302	11,9	351,91	1
S	RTS 110.400	110	4,3	402	15,8	463,60	1
S	RTS 110.500	110	4,3	502	19,8	589,39	1
S	RTS 110.600	110	4,3	602	23,7	732,32	1
F	RTS 110.100 F	110	4,3	102	4	188,63	1
F	RTS 110.150 F	110	4,3	152	6	226,22	1
F	RTS 110.200 F	110	4,3	202	8	283,47	1
F	RTS 110.300 F	110	4,3	302	11,9	387,30	1
F	RTS 110.400 F	110	4,3	402	15,8	510,20	1
F	RTS 110.500 F	110	4,3	502	19,8	648,57	1
F	RTS 110.600 F	110	4,3	602	23,7	804,21	1

Height 110 mm
Nominal 4 3/8 inches

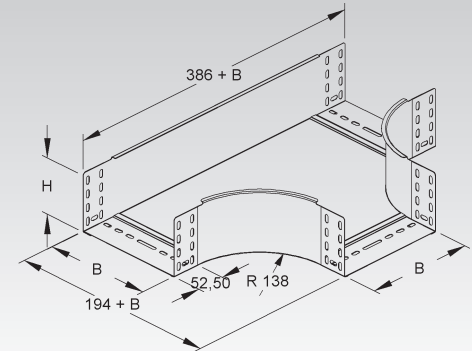

Horizontal Cross

with integrated splice

	model no.	height H		inside dimension (B)		Weight per 100 pcs./pc./ kg	Pack/Box Qty
		mm	Inch	mm	Inch		
S	RKS 110.100	110	4,3	102	4	216,46	1
S	RKS 110.150	110	4,3	152	6	256,03	1
S	RKS 110.200	110	4,3	202	8	301,93	1
S	RKS 110.300	110	4,3	302	11,9	400,69	1
S	RKS 110.400	110	4,3	402	15,8	517,56	1
S	RKS 110.500	110	4,3	502	19,8	647,72	1
S	RKS 110.600	110	4,3	602	23,7	797,59	1
F	RKS 110.100 F	110	4,3	102	4	238,35	1
F	RKS 110.150 F	110	4,3	152	6	281,87	1
F	RKS 110.200 F	110	4,3	202	8	332,42	1
F	RKS 110.300 F	110	4,3	302	11,9	441,06	1
F	RKS 110.400 F	110	4,3	402	15,8	569,68	1
F	RKS 110.500 F	110	4,3	502	19,8	712,85	1
F	RKS 110.600 F	110	4,3	602	23,7	878,25	1

Height 110 mm
Nominal 4 3/8 inches

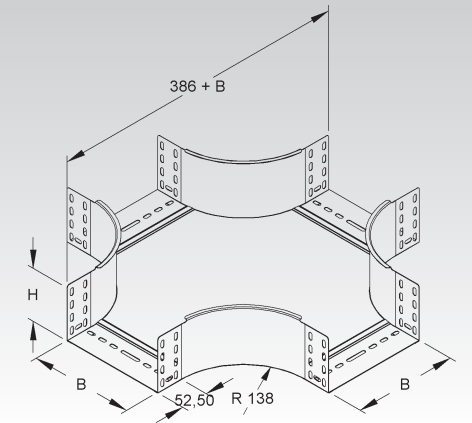

Reducer/Blind End

	model no.	height H		width B		width B1		Weight per 100 pcs./pc./ kg	Pack/Box Qty
		mm	Inch	mm	Inch	mm	Inch		
S	RA 110.050	110	4,3	50	2	172	6,8	18,64	20
S	RA 110.150	110	4,3	150	5,9	272	10,7	29,14	20
S	RA 110.200	110	4,3	200	7,9	322	12,7	34,39	20
S	RA 110.350	110	4,3	350	13,8	472	18,6	50,13	20
S	RA 110.400	110	4,3	400	15,7	522	20,6	55,38	20
S	RA 110.500	110	4,3	500	19,7	622	24,5	65,87	20
S	RA 110.600	110	4,3	600	23,6	722	28,4	76,37	20
F	RA 110.050 F	110	4,3	50	2	172	6,8	20,68	1
F	RA 110.150 F	110	4,3	150	5,9	272	10,7	32,23	1
F	RA 110.200 F	110	4,3	200	7,9	322	12,7	38,01	1
F	RA 110.350 F	110	4,3	350	13,8	472	18,6	55,32	1
F	RA 110.400 F	110	4,3	400	15,7	522	20,6	61,10	1
F	RA 110.500 F	110	4,3	500	19,7	622	24,5	72,64	1
F	RA 110.600 F	110	4,3	600	23,6	722	28,4	84,19	1
E3	RA 110.050 E3	110	4,3	50	2	172	6,8	17,30	20
E3	RA 110.200 E3	110	4,3	200	7,9	322	12,7	31,58	20
E3	RA 110.400 E3	110	4,3	400	15,7	522	20,6	50,63	20
E3	RA 110.500 E3	110	4,3	500	19,7	622	24,5	60,15	20
E3	RA 110.600 E3	110	4,3	600	23,6	722	28,4	69,68	20

Height 110 mm
Nominal 4 3/8 inches

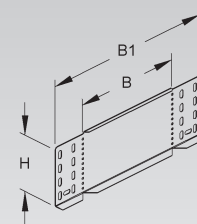

can be used as blind end or as reducer for cable trays



Adjustable Horizontal Splice/Reducer/Blind End

model no.	height H		width B		width B1	Weight per 100 pcs kg	Pack/Box Qty	
	mm	Inch	mm	Inch				
S RAW 110.100	110	4,3	100	3,9	222	8,7	23,60	20
S RAW 110.300	110	4,3	300	11,8	422	16,6	44,59	20
F RAW 110.100 F	110	4,3	100	3,9	222	8,7	26,14	1
F RAW 110.300 F	110	4,3	300	11,8	422	16,6	49,23	1
E3 RAW 110.100 E3	110	4,3	100	3,9	222	8,7	21,80	20
E3 RAW 110.300 E3	110	4,3	300	11,8	422	16,6	40,85	20

can be used as blind end or as reducer for cable trays

Height 110 mm
Nominal 4 3/8 inches

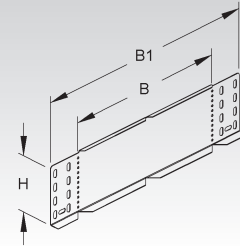

Adjustable Vertical Splice Plate

model no.	height H		Weight per 100 pcs kg	Pack/Box Qty
	mm	Inch		
S RGV 110	93	3,7	40,99	25
F RGV 110 F	93	3,7	44,51	25
E3 RGV 110 E3	93	3,7	28,98	25

2 pieces required per joint

Height 110 mm
Nominal 4 3/8 inches

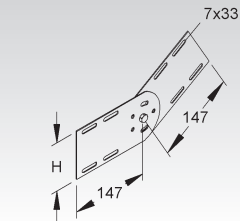

Splice/Link Kit

model no.	height H		width B		Weight per 100 pcs/pc. / kg	Pack/Box Qty
	mm	Inch	mm	Inch		
S RGE 110.100	110	4,3	100	3,9	97,55	1
S RGE 110.150	110	4,3	150	5,9	102,69	1
S RGE 110.200	110	4,3	200	7,9	107,83	1
S RGE 110.300	110	4,3	300	11,8	118,11	1
S RGE 110.400	110	4,3	400	15,7	128,39	1
S RGE 110.500	110	4,3	500	19,7	138,67	1
S RGE 110.600	110	4,3	600	23,6	148,94	1
F RGE 110.100 F	110	4,3	100	3,9	66,00	1
F RGE 110.150 F	110	4,3	150	5,9	112,62	1
F RGE 110.200 F	110	4,3	200	7,9	79,00	1
F RGE 110.300 F	110	4,3	300	11,8	129,58	1
F RGE 110.400 F	110	4,3	400	15,7	103,00	1
F RGE 110.500 F	110	4,3	500	19,7	115,00	1
F RGE 110.600 F	110	4,3	600	23,6	163,49	1

for linking sections of tray with a vertical displacement

Height 110 mm
Nominal 4 3/8 inches

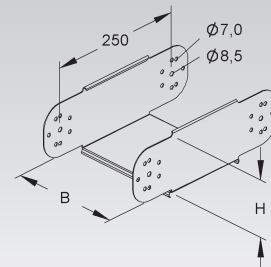

Vertical Inside Elbow 45°

with integrated splice

model no.	height H		inside dimension (B)		Weight per 100 pcs/pc. / kg	Pack/Box Qty
	mm	Inch	mm	Inch		
S RSB 110.100	110	4,3	102	4	70,30	1
S RSB 110.150	110	4,3	152	6	82,30	1
S RSB 110.200	110	4,3	202	8	91,80	1
S RSB 110.300	110	4,3	302	11,9	113,40	1
S RSB 110.400	110	4,3	402	15,8	134,90	1
S RSB 110.500	110	4,3	502	19,8	159,16	1
S RSB 110.600	110	4,3	602	23,7	181,57	1

Height 110 mm
Nominal 4 3/8 inches

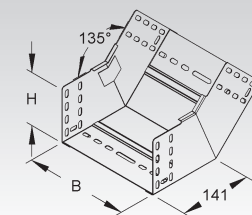

CABLE TRAY SYSTEM

Vertical Inside Elbow 90°

with integrated splice

	model no.	height H		inside dimension (B)		Weight per 100 pcs./pc./ kg	Pack/Box Qty
		mm	Inch	mm	Inch		
S	RSD 110.100	110	4,3	102	4	100,16	1
S	RSD 110.150	110	4,3	152	6	117,35	1
S	RSD 110.200	110	4,3	202	8	135,46	1
S	RSD 110.300	110	4,3	302	11,9	169,84	1
S	RSD 110.400	110	4,3	402	15,8	205,14	1
S	RSD 110.500	110	4,3	502	19,8	239,52	1
S	RSD 110.600	110	4,3	602	23,7	273,90	1

Height
110
mm

Nominal
4 3/8
inches

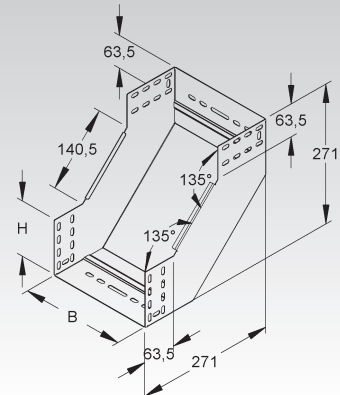

Vertical Outside Elbow 45°

with integrated splice

	model no.	height H		inside dimension (B)		Weight per 100 pcs./pc./ kg	Pack/Box Qty
		mm	Inch	mm	Inch		
S	RFB 110.100	110	4,3	102	4	62,00	1
S	RFB 110.150	110	4,3	152	6	70,60	1
S	RFB 110.200	110	4,3	202	8	76,50	1
S	RFB 110.300	110	4,3	302	11,9	91,00	1
S	RFB 110.400	110	4,3	402	15,8	105,40	1
S	RFB 110.500	110	4,3	502	19,8	122,80	1
S	RFB 110.600	110	4,3	602	23,7	137,99	1

Height
110
mm

Nominal
4 3/8
inches

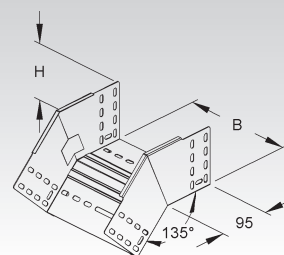

Vertical Outside Elbow 90°

with integrated splice

	model no.	height H		inside dimension (B)		Weight per 100 pcs./pc./ kg	Pack/Box Qty
		mm	Inch	mm	Inch		
S	RFD 110.100	110	4,3	102	4	106,26	1
S	RFD 110.150	110	4,3	152	6	119,62	1
S	RFD 110.200	110	4,3	202	8	133,78	1
S	RFD 110.300	110	4,3	302	11,9	160,51	1
S	RFD 110.400	110	4,3	402	15,8	188,59	1
S	RFD 110.500	110	4,3	502	19,8	214,75	1
S	RFD 110.600	110	4,3	602	23,7	241,48	1

Height
110
mm

Nominal
4 3/8
inches

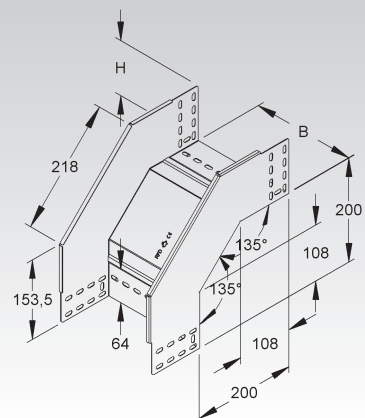

Vertical Tee Down, lengthwise

with integrated splice

	model no.	height H		width B		length A		Weight per 100 pcs./pc./ kg	Pack/Box Qty
		mm	Inch	mm	Inch	mm	Inch		
S	RTL 110.150	110	4,3	150	5,9	251	9,9	187,06	1
S	RTL 110.200	110	4,3	200	7,9	301	11,9	264,54	1
S	RTL 110.300	110	4,3	300	11,8	501	19,7	446,99	1
S	RTL 110.400	110	4,3	400	15,7	801	31,5	575,62	1
S	RTL 110.500	110	4,3	500	19,7	901	35,5	712,49	1
S	RTL 110.600	110	4,3	600	23,6	1001	39,4	868,26	1

Size of run and tap tray is identical.

Height
110 mm
Nominal
4 3/8 inches

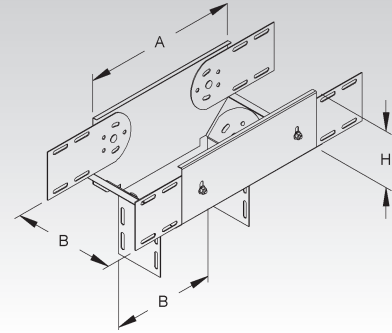

Vertical Tee Down, crosswise

with integrated splice

	model no.	height H		inside dimension (B)		length A		Weight per 100 pcs./pc./ kg	Pack/Box Qty
		mm	Inch	mm	Inch	mm	Inch		
S	RTQ 110.100	110	4,3	102	4	361	14,2	144,98	1
S	RTQ 110.150	110	4,3	152	6	361	14,2	162,26	1
S	RTQ 110.200	110	4,3	202	8	361	14,2	181,14	1
S	RTQ 110.300	110	4,3	302	11,9	361	14,2	215,70	1
S	RTQ 110.400	110	4,3	402	15,8	361	14,2	251,86	1
S	RTQ 110.500	110	4,3	502	19,8	361	14,2	286,42	1
S	RTQ 110.600	110	4,3	602	23,7	361	14,2	322,42	1

Size of run and tap tray is identical.

Height
110 mm
Nominal
4 3/8 inches

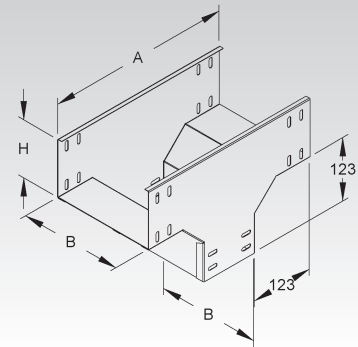

Edge Protection Plate

	model no.	width B		Weight per 100 pcs./pc./ kg	Pack/Box Qty
		mm	Inch		
S	RKB 100	92	3,6	4,22	10
S	RKB 150	142	5,6	6,82	10
S	RKB 200	192	7,6	8,77	10
S	RKB 300	292	11,5	12,84	10
S	RKB 400	392	15,4	16,91	10
S	RKB 500	492	19,4	20,98	10
S	RKB 600	592	23,3	25,05	10
F	RKB 100 F	92	3,6	4,66	50
F	RKB 150 F	142	5,6	7,54	50
F	RKB 200 F	192	7,6	9,69	50
F	RKB 300 F	292	11,5	14,16	50
F	RKB 400 F	392	15,4	18,64	50
F	RKB 500 F	492	19,4	23,12	50
F	RKB 600 F	592	23,3	27,60	50
E3	RKB 100 E3	92	3,6	4,35	10
E3	RKB 200 E3	192	7,6	9,04	10
E3	RKB 300 E3	292	11,5	13,13	10
E3	RKB 400 E3	392	15,4	17,23	10
E3	RKB 500 E3	492	19,4	21,32	10
E3	RKB 600 E3	592	23,3	25,42	10

with rounded edges to protect cables at the joint and to reinforce the bottom of cable trays

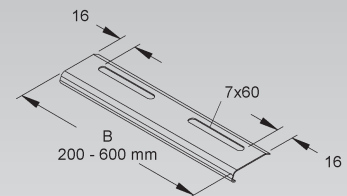

CABLE TRAY SYSTEM COVERS

Cover

model no.	inside dimension (B) mm Inch	Weight per 100 m kg	Pack/Box Qty
S RD 100	100 3,9	73,00	2 x 3 m
S RD 150	150 5,9	102,42	2 x 3 m
S RD 200	200 7,9	131,90	2 x 3 m
S RD 300	300 11,8	228,80	2 x 3 m
S RD 400	400 15,7	332,70	2 x 3 m
S RD 500	500 19,7	411,20	2 x 3 m
S RD 600	600 23,6	489,70	2 x 3 m
F RD 100 F	100 3,9	80,28	2 x 3 m
F RD 150 F	150 5,9	112,70	2 x 3 m
F RD 200 F	200 7,9	145,04	2 x 3 m
F RD 300 F	300 11,8	251,72	2 x 3 m
F RD 400 F	400 15,7	366,00	2 x 3 m
F RD 500 F	500 19,7	452,30	2 x 3 m
F RD 600 F	600 23,6	538,70	2 x 3 m
E3 RD 100 E3	100 3,9	78,33	2 x 3 m
E3 RD 200 E3	200 7,9	141,53	2 x 3 m
E3 RD 300 E3	300 11,8	203,47	2 x 3 m
E3 RD 400 E3	400 15,7	266,67	2 x 3 m
E3 RD 500 E3	500 19,7	372,49	2 x 3 m
E3 RD 600 E3	600 23,6	443,59	2 x 3 m

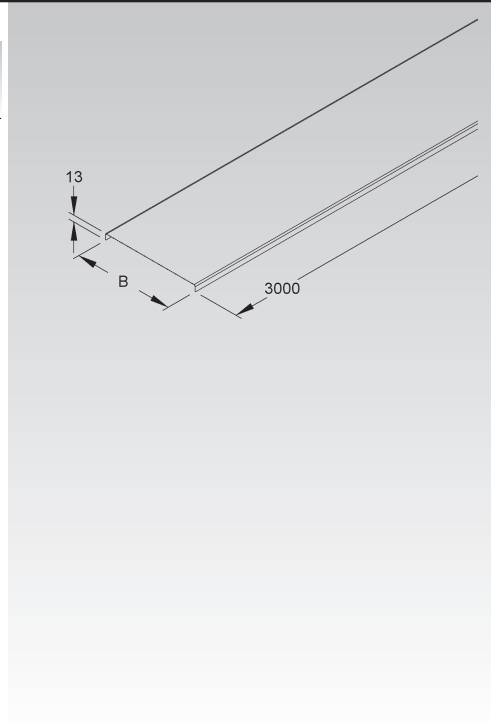

Suitable for: all straight sections of cable tray (other than RSV 50...), Wire Mesh Tray as well as for KL... cable ladders

For outdoor service covers need to be secured against windloads using heavy duty cover clamps or steel cable ties.

Cover for Cable Tray/Ladder

with turnbolt locks

model no.	inside dimension (B) mm Inch	Weight per 100 m kg	Pack/Box Qty
S RDV 100	100 3,9	74,40	2 x 3 m
S RDV 150	150 5,9	103,80	2 x 3 m
S RDV 200	200 7,9	133,20	2 x 3 m
S RDV 300	300 11,8	230,20	2 x 3 m
S RDV 400	400 15,7	334,10	2 x 3 m
S RDV 500	500 19,7	412,60	2 x 3 m
S RDV 600	600 23,6	491,10	2 x 3 m
F RDV 100 F	100 3,9	81,80	2 x 3 m
F RDV 150 F	150 5,9	114,20	2 x 3 m
F RDV 200 F	200 7,9	146,60	2 x 3 m
F RDV 300 F	300 11,8	253,20	2 x 3 m
F RDV 400 F	400 15,7	367,50	2 x 3 m
F RDV 500 F	500 19,7	453,80	2 x 3 m
F RDV 600 F	600 23,6	540,20	2 x 3 m
E3 RDV 100 E3	100 3,9	80,42	2 x 3 m
E3 RDV 200 E3	200 7,9	143,62	2 x 3 m
E3 RDV 300 E3	300 11,8	205,56	2 x 3 m
E3 RDV 400 E3	400 15,7	268,76	2 x 3 m
E3 RDV 500 E3	500 19,7	374,58	2 x 3 m
E3 RDV 600 E3	600 23,6	445,68	2 x 3 m

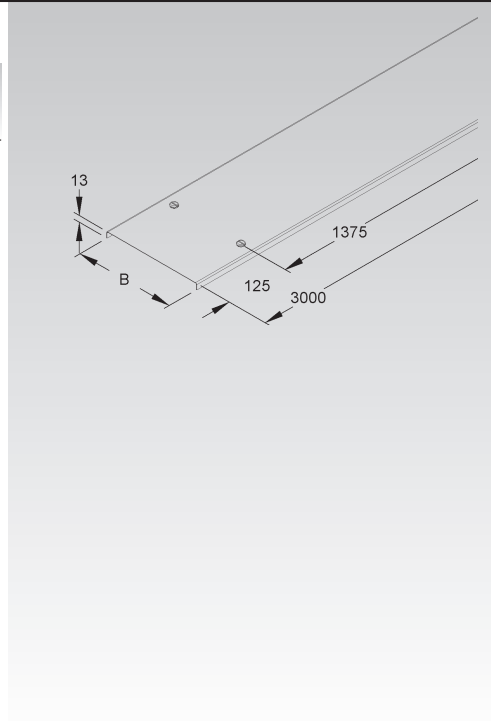

Suitable for: all straight sections of cable tray (other than RSV 50...) as well as for KL... cable ladders

For outdoor service covers need to be secured against windloads using heavy duty cover clamps or steel cable ties.



Cover for Horizontal Extension Tee

with turnbolt locks

	model no.	inside dimension (B) mm Inch	Weight per 100 pcs kg	Pack/Box Qty
S	RTADV 100	104 4,1	43,37	1
S	RTADV 150	154 6,1	51,99	1
S	RTADV 200	204 8	60,61	1
S	RTADV 300	304 12	77,85	1
S	RTADV 400	404 15,9	95,09	1
S	RTADV 500	504 19,8	112,32	1
S	RTADV 600	604 23,8	129,56	1
F	RTADV 100 F	104 4,1	52,44	1
F	RTADV 150 F	154 6,1	57,97	1
F	RTADV 200 F	204 8	67,45	1
F	RTADV 300 F	304 12	86,42	1
F	RTADV 400 F	404 15,9	105,37	1
F	RTADV 500 F	504 19,8	124,33	1
F	RTADV 600 F	604 23,8	143,29	1
E3	RTADV 100 E3	104 4,1	39,61	1
E3	RTADV 200 E3	204 8	55,03	1
E3	RTADV 300 E3	304 12	70,45	1
E3	RTADV 400 E3	404 15,9	106,91	1
E3	RTADV 500 E3	504 19,8	126,19	1
E3	RTADV 600 E3	604 23,8	145,47	1

Suitable for: RTA... extension horizontal tees

For outdoor service covers need to be secured against windloads using heavy duty cover clamps or steel cable ties.

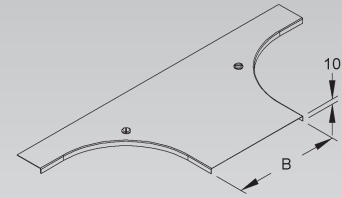

Cover for Flexible Horizontal Fitting

	model no.	inside dimension (B) mm Inch	Weight per 100 pcs kg	Pack/Box Qty
S	RBAVD 100	102 4	32,50	1
S	RBAVD 150	152 6	61,00	1
S	RBAVD 200	202 8	97,65	1
S	RBAVD 300	302 11,9	198,20	1
S	RBAVD 400	402 15,8	332,60	1
S	RBAVD 500	502 19,8	501,80	1
S	RBAVD 600	602 23,7	705,20	1

adjustable from 0-90°

Suitable for: RBAV... flexible horizontal elbow

RDHF 9 E2 cover clamps shall not be used when covers are installed vertically.

4 x RDHF 9 E2 cover clips required per cover. Please order separately.

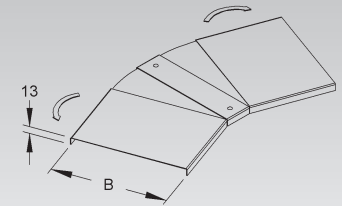

CABLE TRAY SYSTEM COVERS

Cover for 90° Horizontal Elbow

with turnbolt locks

model no.		inside dimension (B) mm Inch	Weight per 100 pcs kg	Pack/Box Qty
S	RESDV 100	104 4,1	39,00	1
S	RESDV 150	154 6,1	69,62	1
S	RESDV 200	204 8	96,39	1
S	RESDV 300	304 12	160,52	1
S	RESDV 400	404 15,9	238,78	1
S	RESDV 500	504 19,8	367,73	1
S	RESDV 600	604 23,8	486,08	1
F	RESDV 100 F	104 4,1	44,10	1
F	RESDV 150 F	154 6,1	77,79	1
F	RESDV 200 F	204 8	107,23	1
F	RESDV 300 F	304 12	177,78	1
F	RESDV 400 F	404 15,9	263,87	1
F	RESDV 500 F	504 19,8	405,71	1
F	RESDV 600 F	604 23,8	535,91	1
E3	RESDV 100 E3	104 4,1	42,80	1
E3	RESDV 200 E3	204 8	87,54	1
E3	RESDV 300 E3	304 12	144,91	1
E3	RESDV 400 E3	404 15,9	267,85	1
E3	RESDV 500 E3	504 19,8	371,16	1
E3	RESDV 600 E3	604 23,8	490,27	1

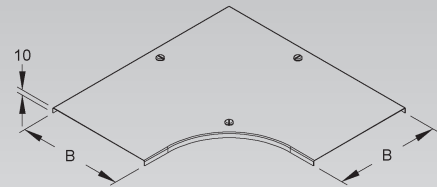

Suitable for: RES... horizontal 90° elbows

For outdoor service covers need to be secured against windloads using heavy duty cover clamps or steel cable ties.

Cover for Horizontal Tee

with turnbolt locks

model no.		inside dimension (B) mm Inch	Weight per 100 pcs kg	Pack/Box Qty
S	RTSDV 100	104 4,1	72,04	1
S	RTSDV 150	154 6,1	104,94	1
S	RTSDV 200	204 8	141,76	1
S	RTSDV 300	304 12	227,18	1
S	RTSDV 400	404 15,9	328,30	1
S	RTSDV 500	504 19,8	445,13	1
S	RTSDV 600	604 23,8	577,65	1
F	RTSDV 100 F	104 4,1	80,40	1
F	RTSDV 150 F	154 6,1	80,00	1
F	RTSDV 200 F	204 8	157,00	1
F	RTSDV 300 F	304 12	251,20	1
F	RTSDV 400 F	404 15,9	362,30	1
F	RTSDV 500 F	504 19,8	490,80	1
F	RTSDV 600 F	604 23,8	636,50	1

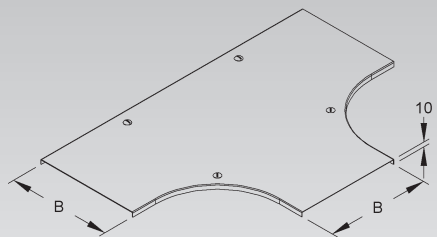

Suitable for: RTS... horizontal tee

For outdoor service covers need to be secured against windloads using heavy duty cover clamps or steel cable ties.



Cover for Horizontal Cross

with turnbolt locks

	model no.	inside dimension (B)		Weight per 100 pcs kg	Pack/Box Qty
		mm	Inch		
S	RKSDV 100	104	4,1	95,41	1
S	RKSDV 150	154	6,1	135,44	1
S	RKSDV 200	204	8	179,40	1
S	RKSDV 300	304	12	279,10	1
S	RKSDV 400	404	15,9	394,49	1
S	RKSDV 500	504	19,8	525,59	1
S	RKSDV 600	604	23,8	672,38	1
F	RKSDV 100 F	104	4,1	106,57	1
F	RKSDV 150 F	154	6,1	150,60	1
F	RKSDV 200 F	204	8	198,96	1
F	RKSDV 300 F	304	12	308,63	1
F	RKSDV 400 F	404	15,9	435,56	1
F	RKSDV 500 F	504	19,8	579,77	1
F	RKSDV 600 F	604	23,8	741,24	1

Suitable for: RKS... horizontal crosses

For outdoor service covers need to be secured against windloads using heavy duty cover clamps or steel cable ties.

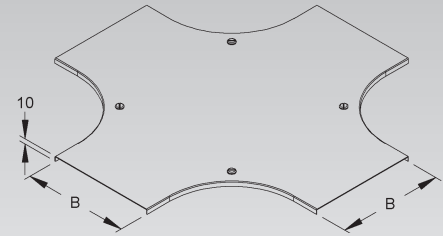

Cover for Vertical Outside Elbow Kit

with turnbolt locks

	model no.	inside dimension (B)		Weight per 100 pcs/pc. kg	Pack/Box Qty
		mm	Inch		
S	RFSDDV 60.100	104	4,1	18,0	1
S	RFSDDV 60.150	154	6,1	25,0	1
S	RFSDDV 60.200	204	8	32,0	1
S	RFSDDV 60.300	304	12	46,0	1
S	RFSDDV 60.400	404	15,9	59,9	1
S	RFSDDV 60.500	504	19,8	73,9	1
S	RFSDDV 60.600	604	23,8	87,9	1

Suitable for: vertical inside/outside elbow kit with a side rail height of 60 mm, type RFD 60... and RSD 60...

For outdoor service covers need to be secured against windloads using heavy duty cover clamps or steel cable ties.

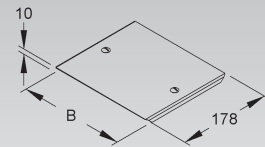

Cover for Vertical Outside Elbow Kit

with turnbolt locks

	model no.	inside dimension (B)		Weight per 100 pcs kg	Pack/Box Qty
		mm	Inch		
S	RFDDV 85.100	104	4,1	20,7	1
S	RFDDV 85.200	204	8	36,4	1
S	RFDDV 85.300	304	12	52,1	1
S	RFDDV 85.400	404	15,9	67,8	1
S	RFDDV 85.500	504	19,8	83,5	1
S	RFDDV 85.600	604	23,8	99,2	1

Suitable for: vertical inside/outside elbow kit with a side rail height of 85 mm, type RFD 85...

For outdoor service covers need to be secured against windloads using heavy duty cover clamps or steel cable ties.

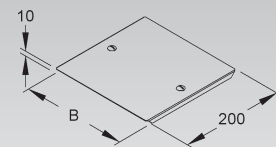

CABLE TRAY SYSTEM COVERS

Cover for Vertical Inside Elbow

with turnbolt locks

model no.	inside dimension (B) mm Inch	Weight per 100 pcs kg	Pack/Box Qty
S RSDDV 85.100	104 4,1	16,25	1
S RSDDV 85.200	204 8	28,49	1
S RSDDV 85.300	304 12	40,74	1
S RSDDV 85.400	404 15,9	52,99	1
S RSDDV 85.500	504 19,8	65,23	1
S RSDDV 85.600	604 23,8	77,48	1

Suitable for: cable tray vertical inside/outside elbow for side rail height of 85 mm, type RSD 85...
For outdoor service covers need to be secured against windloads using heavy duty cover clamps or steel cable ties.

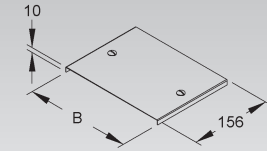

Cover for Vertical Outside Elbow Kit

with turnbolt locks

model no.	inside dimension (B) mm Inch	Weight per 100 pcs/pc. kg	Pack/Box Qty
S RFDDV 110.100	104 4,1	22,60	1
S RFDDV 110.150	154 6,1	31,20	1
S RFDDV 110.200	204 8	39,31	1
S RFDDV 110.300	304 12	57,10	1
S RFDDV 110.400	404 15,9	74,40	1
S RFDDV 110.500	504 19,8	91,70	1
S RFDDV 110.600	604 23,8	108,90	1

Suitable for: vertical inside/outside elbow kit with a side rail height of 110 mm, type RFD 110...
For outdoor service covers need to be secured against windloads using heavy duty cover clamps or steel cable ties.

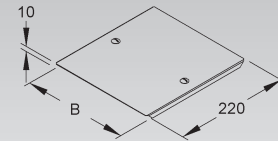

Cover for Vertical Inside Elbow

with turnbolt locks

model no.	inside dimension (B) mm Inch	Weight per 100 pcs/pc. kg	Pack/Box Qty
S RSDDV 110.100	104 4,1	14,23	1
S RSDDV 110.150	154 6,1	19,52	1
S RSDDV 110.200	204 8	24,82	1
S RSDDV 110.300	304 12	35,42	1
S RSDDV 110.400	404 15,9	46,02	1
S RSDDV 110.500	504 19,8	56,62	1
S RSDDV 110.600	604 23,8	67,21	1

Suitable for: cable tray vertical inside/outside elbow for side rail height of 110 mm, type RSD 110 ...
For outdoor service covers need to be secured against windloads using heavy duty cover clamps or steel cable ties.

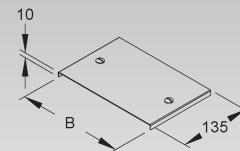

Turnbolt Lock

locking nut included

	model no.	Weight per 100 pcs kg	Pack/Box Qty
S	RDRS 9	1,2	100
F	RDRS 9 F	1,6	100
E3	RDRS 9 E3	1,6	100

for field modifications of covers

Suitable for: RD... and RDV... covers fitting covers

Not sufficient for securing covers to tray installed vertically or sideways nor for securing covers against windloads. Please use self tapping screws, steel cable ties or cover-hinges in addition.

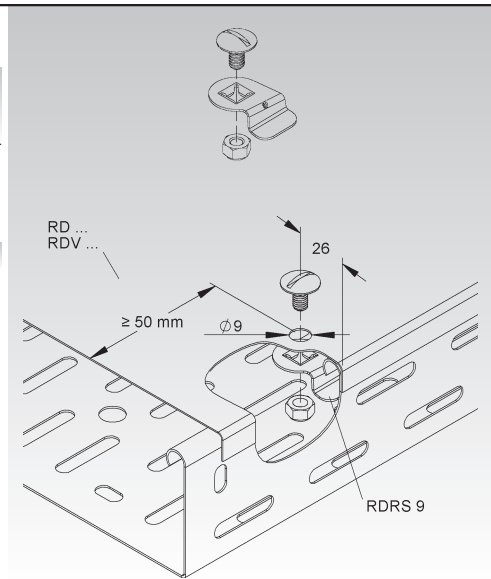

Turnbolt Lock

locking nut included

	model no.	Weight per 100 pcs kg	Pack/Box Qty
S	RDRS 2	1,3	100
E3	RDRS 2 E3	1,5	100

Suitable for: all R-series fitting covers and RSV 50.100 distribution tray covers

Not sufficient for securing covers to tray installed vertically or sideways nor for securing covers against windloads. Please use self tapping screws, steel cable ties or cover-hinges in addition.

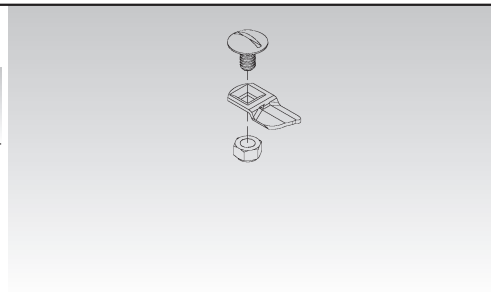

Exterior Cover Clamp

	model no.	height H		Weight per 100 pcs kg	Pack/Box Qty
		mm	Inch		
E2	RDHK 60 E2	58	2,3	1,71	50
E2	RDHK 110 E2	108	4,3	2,57	50

Suitable for: all tray and fitting covers in 60 mm or 110 mm height

Not sufficient for securing covers to tray installed vertically or sideways nor for securing covers against windloads. Please use self tapping screws, steel cable ties or cover-hinges in addition.

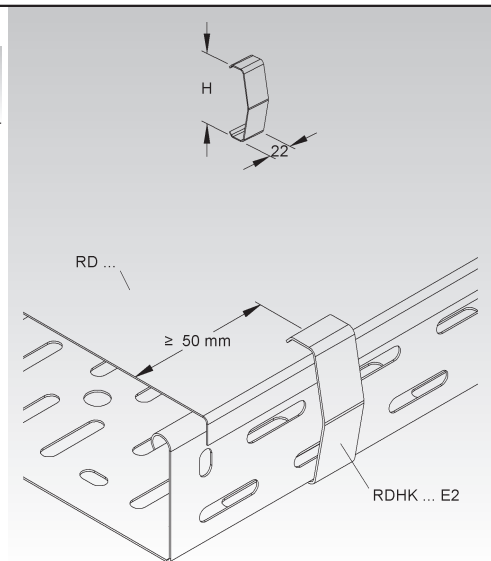

CABLE TRAY SYSTEM COVERS

Cover Clamp

model no.	Weight per 100 pcs kg	Pack/Box Qty
E2 RDHF 9 E2	0,47	60

Suitable for: RD... and RDV... covers

Not sufficient for securing covers to tray installed vertically or sideways nor for securing covers against windloads. Please use self tapping screws, steel cable ties or cover-hinges in addition.

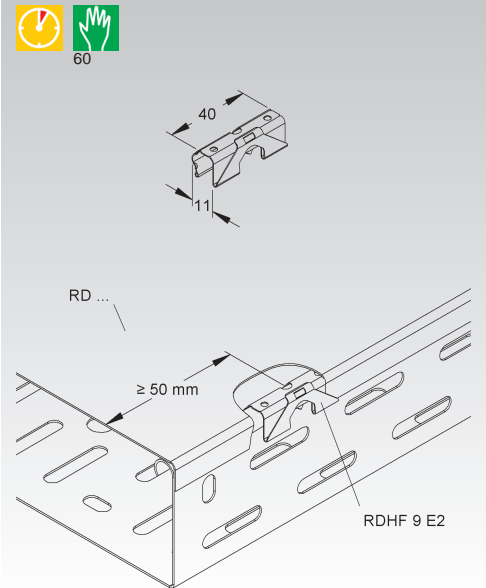

NOTES



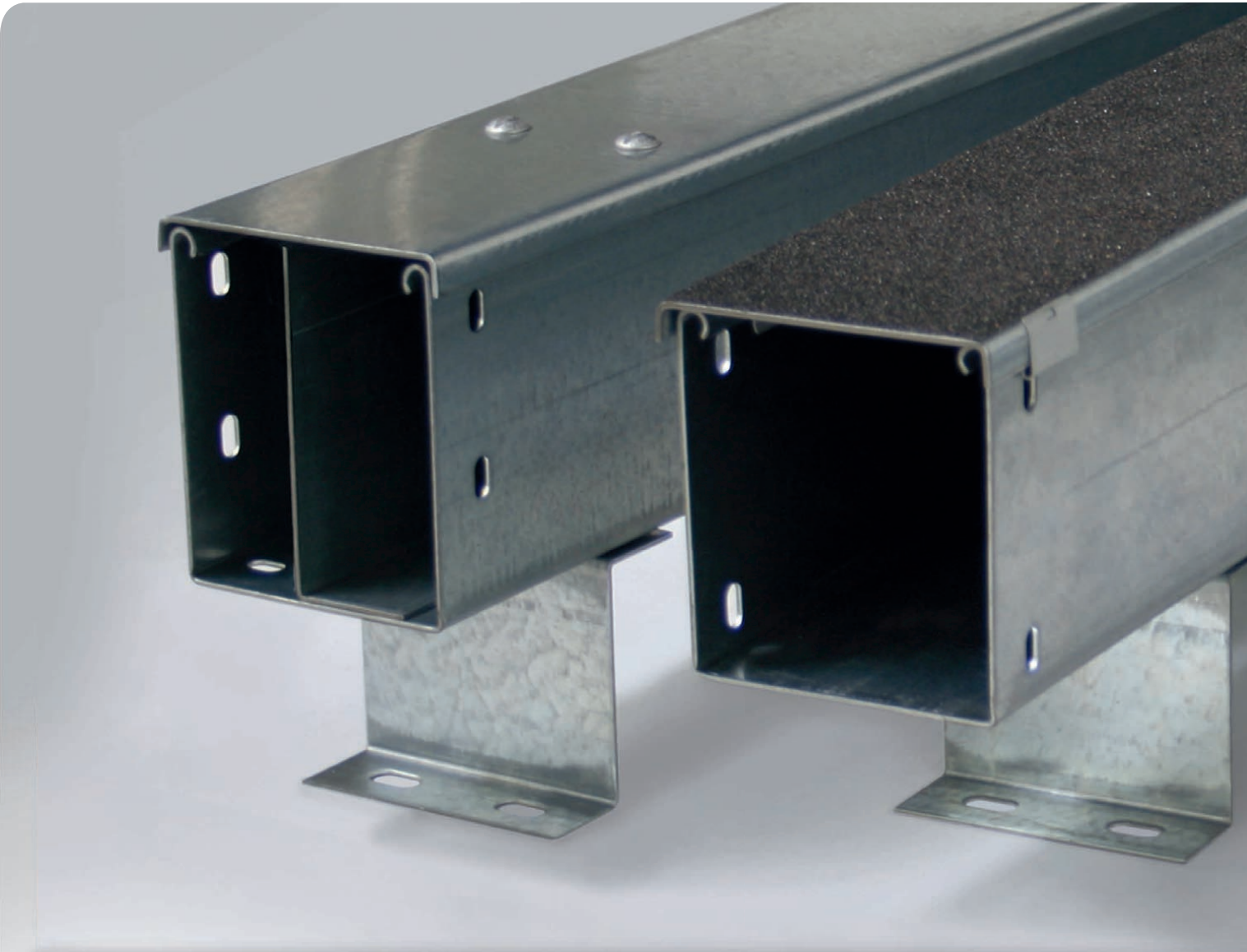

WALKABLE CABLE TRAY

- Walkable Cable Tray
- Covers
- Barrier Strips
- Fittings
- Accessoires



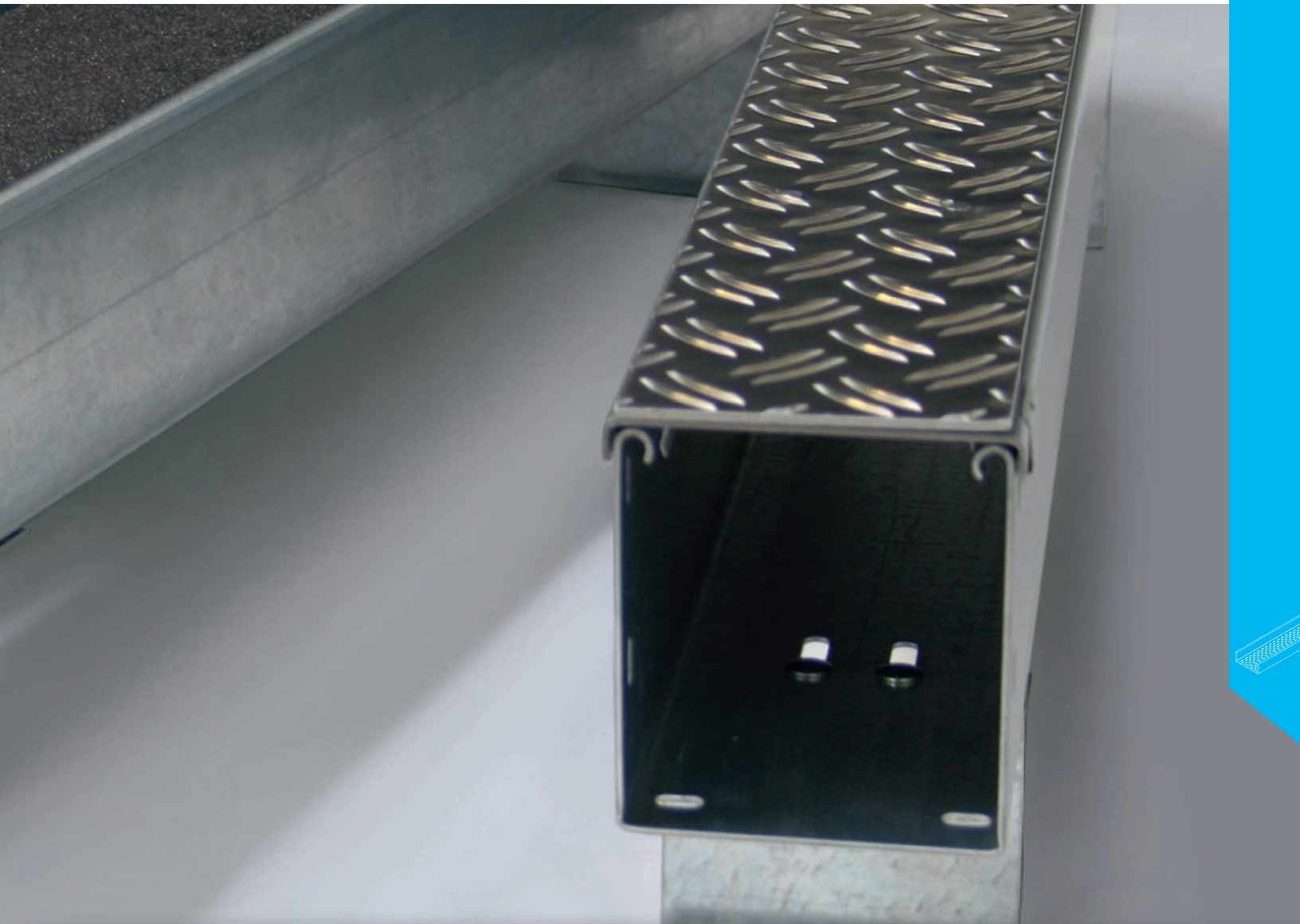

Niedax walkable cable tray was developed together with and especially for the automotive industry. Based on Niedax experience in manufacturing cable tray a special heavy duty version, that could be used as a walkway, was created. Different kinds of covers, ex. with aluminum checker plates are available. Flexible horizontal fittings allow an easy installation in between all kinds of production machinery like welding robots.

CABLE TRAY SYSTEM

Available Side Rail Heights

↑ Height 100 mm	Nominal 4 inches	↑ Height 110 mm	Nominal 4 3/8 inches
-----------------------	------------------------	-----------------------	----------------------------

SYSTEM	ZUBEHÖR	Product Code	100 mm	110 mm
★	Heavy duty cable tray	RSQLS...	Page 224*	Page 226
★	Universal Splice Plate	RSUV...-1.5	Page 224*	Page 227
★	Divider	RTSKQ...	Page 224*	Page 227
★	Flexible Divider	RTSQF...	Page 224*	Page 227*
★	Elbow 45°	RBAS...	Page 225*	Page 227
★	Elbow 90°	RESS...	Page 225*	Page 228
★	Extension Tee	RTAS...	Page 225*	Page 228
★	Horizontal Tee	RTSS...	Page 225*	Page 228
★	Reducer/Blind End	RA...	Page 226*	Page 228
★	Adjustable Horizontal Splice/Reducer/Blind End	RAW...	Page 226*	Page 229
★	End Plate with Cover Lock	RADS...	Page 226*	Page 229*
	Heavy Duty Cover	RDS...	Page 229	
	Heavy Duty Cover	RDVS...	Page 229	
★	Heavy Duty Antiskid Cover (DIN 51130 class R10)	RDRS...	Page 230	
	Heavy Duty Aluminium Checker Plate Cover	RDVSRSL...	Page 230	
	Heavy Duty Cover for 45° Horizontal Elbow	RBADVS...	Page 230	
★	Heavy Duty Antiskid Cover for 45° Horizontal Elbow	RBADVRS...	Page 230	
	Aluminum Checker Plate Cover for 45° Horizontal Elbow	RBADVSRSL...	Page 231	
	Heavy Duty Cover for 90° Horizontal Elbow	RESDVS...	Page 231	
★	Heavy Duty Antiskid Cover for 90° Horizontal Elbow	RESDVRS...	Page 231	
	Aluminum Checker Plate Cover for 90° Horizontal Elbow	RESDVSRSL...	Page 231	
	Heavy Duty Cover for Horizontal Extension Tee	RTADV...	Page 232	
★	Heavy Duty Antiskid Cover for Horizontal Extension Tee	RTADVRS...	Page 232	
	Aluminum Checker Plate Cover for Horizontal Extension Tee	RTADVSRSL...	Page 232	
	Heavy Duty Cover for Horizontal Tee	RTSDVS...	Page 232	
★	Aluminum Checker Plate Cover for Horizontal Tee	RTSDVRS...	Page 233	
	Aluminum Checker Plate Cover for Horizontal Tee	RTSDVSRSL...	Page 233	
	Heavy Duty Turnbolt Lock	RDRS 9X2	Page 233	
	Turnbolt Lock	RDRS 2 E3	Page 233	
	Heavy Duty Cover Clamp	RDHFS 9 V	Page 234	
	Floor Mounting Bracket (height: 50 mm)	RZP 50/...	Page 234	
	Floor Mounting Bracket (height: 80 mm)	RZP 80/...	Page 234	
★	Floor Mounting Bracket (height: 100 mm)	RZP 100/...	Page 235	
★	Floor Mounting Bracket (height: 110 mm)	RZP 110/...	Page 235	
★	Floor Stand (height: 85 mm)	RDB 85...	Page 235	
★	Skirting Panel	VBASB 92.8-1.5/3000 S	Page 235	
★	Floor Stand	RSSTAU 108...	Page 236	
	Floor Stand	RSSTAA 108...	Page 236	
★	Skirting Panel	VBASB 106.7-2.0/3000 S	Page 236	
★	Floor Stand	GRBS...	Page 237	
	Mushroom Head Bolt	FLM...	Page 237	
★	Rounded Head Torx Bolt	LFM 6X16-TX V	Page 237	
★	Self-Tapping Screw	B 4.2X13-TX V	Page 237	
	U-Shaped Square Washer	GTL 30 V	Page 238	
★	Nail Anchor	DAM...	Page 238	
	Bolt Anchor	DAZ...	Page 238	

* New



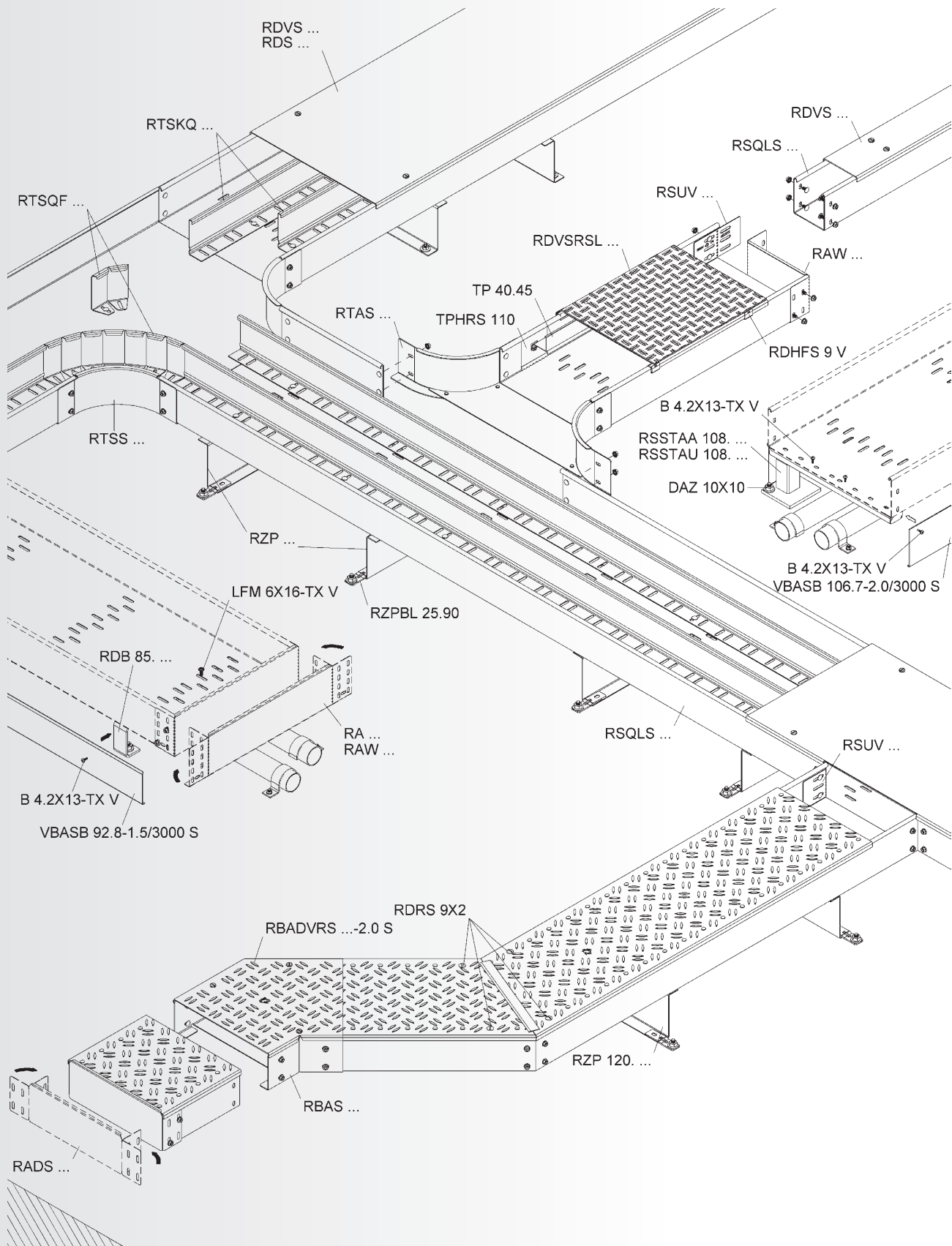

WALKABLE CABLE TRAY SYSTEM

Heavy duty cable tray

with solid sides

model no.	height H		width B		thick-ness t mm	Weight per 100 m kg	Pack/Box Qty
	mm	Inch	mm	Inch			
★ S RSQLS 100.100 S OV	100	3,9	100	3,9	2	496,28	2 x 3 m
★ S RSQLS 100.200 S OV	100	3,9	200	7,9	2	649,13	2 x 3 m
★ S RSQLS 100.300 S OV	100	3,9	300	11,8	2	801,98	2 x 3 m
★ S RSQLS 100.400 S OV	100	3,9	400	15,7	2	954,82	2 x 3 m
★ S RSQLS 100.500 S OV	100	3,9	500	19,7	2	1.107,67	2 x 3 m
★ S RSQLS 100.600 S OV	100	3,9	600	23,6	2	1.260,52	2 x 3 m

Bottom plate with elongated hole pattern for divider and floorstand installation.

RSUV 100-1.5 splice plates are not included.

Height 100 mm
Nominal 4 inches
Eye icon
66

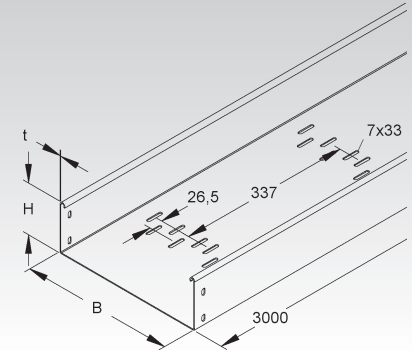

Universal Splice Plate

model no.	height H		width B		thick-ness t mm	Weight per 100 pcs kg	Pack/Box Qty
	mm	Inch	mm	Inch			
★ S RSUV 100-1.5 S	77,5	3,1	150	5,9	1,5	15,58	50

for straight and angled joints

Height 100 mm
Nominal 4 inches
Eye icon
62

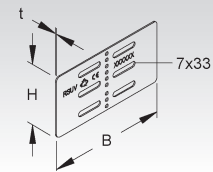

Divider

perforated

model no.	height H		thick-ness t mm	Weight per 100 m kg	Pack/Box Qty
	mm	Inch			
★ S RTSKQ 100-1.5 S	98	3,9	1,5	174,57	3 m
★ S RTSKQ 100-2.0 S	98	3,9	2,0	232,12	3 m

with elongated mounting holes

Minimum number of dividers required to support the walkable covers:

for cover width 100 and 200 mm = none

for cover width 300 mm and 400 mm = 1 piece with a maximum compartment width of 200 mm

for cover width 500 mm and 600 mm = 2 pieces with a maximum compartment width of 200 mm

Height 100 mm
Nominal 4 inches
Eye icon
62 63 66

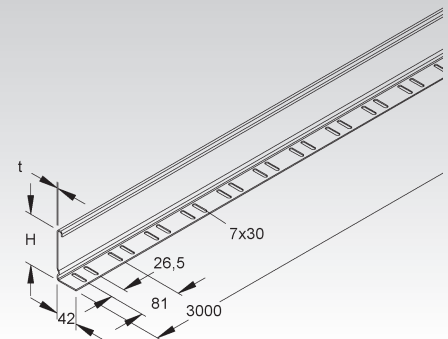

Flexible Divider

with elongated mounting holes

model no.	height H		thick-ness t mm	Weight per 100 m kg	Pack/Box Qty
	mm	Inch			
★ S RTSQF 100-1.5/1000 S	98	3,9	1,5	156,98	1 m

segmented for easy horizontal bending

Height 100 mm
Nominal 4 inches
Eye icon
63

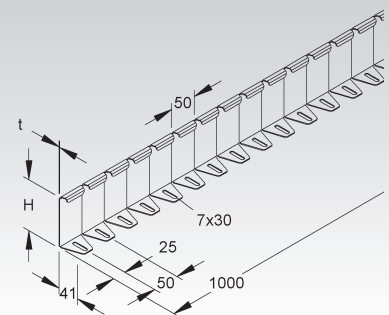

Elbow 45°

solid sides with integrated splice plate

	model no.	height H		inside dimension (B)		thickness t	Weight per 100 pcs kg	Pack/Box Qty
		mm	Inch	mm	Inch			
★	S RBAS 100.100 S	100	3,9	100	3,9	2	117,36	1
★	S RBAS 100.200 S	100	3,9	200	7,9	2	163,50	1
★	S RBAS 100.300 S	100	3,9	300	11,8	2	222,64	1
★	S RBAS 100.400 S	100	3,9	400	15,7	2	294,79	1
★	S RBAS 100.500 S	100	3,9	500	19,7	2	379,94	1
★	S RBAS 100.600 S	100	3,9	600	23,6	2	478,10	1

for horizontal 45° deviations

Height 100 mm
Nominal 4 inches

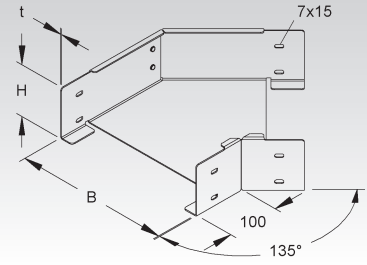

Elbow 90°

solid sides with integrated splice plate

	model no.	height H		inside dimension (B)		thickness t	Weight per 100 pcs kg	Pack/Box Qty
		mm	Inch	mm	Inch			
★	S RESS 100.100 S	100	3,9	100	3,9	2	243,77	1
★	S RESS 100.200 S	100	3,9	200	7,9	2	365,98	1
★	S RESS 100.300 S	100	3,9	300	11,8	2	519,59	1
★	S RESS 100.400 S	100	3,9	400	15,7	2	704,59	1
★	S RESS 100.500 S	100	3,9	500	19,7	2	920,99	1
★	S RESS 100.600 S	100	3,9	600	23,6	2	1.168,80	1

for horizontal 90° deviations

Height 100 mm
Nominal 4 inches

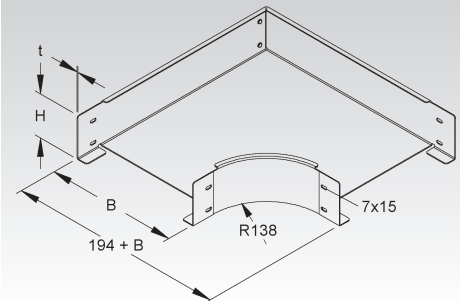

Extension Tee

solid sides with integrated splice plate

	model no.	height H		inside dimension (B)		thickness t	Weight per 100 pcs kg	Pack/Box Qty
		mm	Inch	mm	Inch			
★	S RTAS 100.100 S	100	3,9	100	3,9	2	176,26	1
★	S RTAS 100.200 S	100	3,9	200	7,9	2	196,99	1
★	S RTAS 100.300 S	100	3,9	300	11,8	2	217,71	1
★	S RTAS 100.400 S	100	3,9	400	15,7	2	238,44	1
★	S RTAS 100.500 S	100	3,9	500	19,7	2	259,16	1
★	S RTAS 100.600 S	100	3,9	600	23,6	2	279,88	1

for horizontal tee connections of cable trays

Height 100 mm
Nominal 4 inches

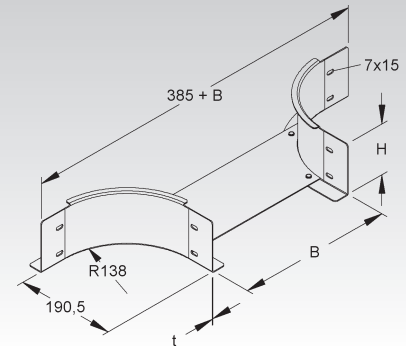

Horizontal Tee

solid sides with integrated splice plate

	model no.	height H		inside dimension (B)		thickness t	Weight per 100 pcs kg	Pack/Box Qty
		mm	Inch	mm	Inch			
★	S RTSS 100.100 S	100	3,9	100	3,9	2	319,79	1
★	S RTSS 100.200 S	100	3,9	200	7,9	2	445,93	1
★	S RTSS 100.300 S	100	3,9	300	11,8	2	603,46	1
★	S RTSS 100.400 S	100	3,9	400	15,7	2	792,40	1
★	S RTSS 100.500 S	100	3,9	500	19,7	2	1.012,74	1
★	S RTSS 100.600 S	100	3,9	600	23,6	2	1.264,48	1

for horizontal tee connections of cable trays with identical width

Height 100 mm
Nominal 4 inches

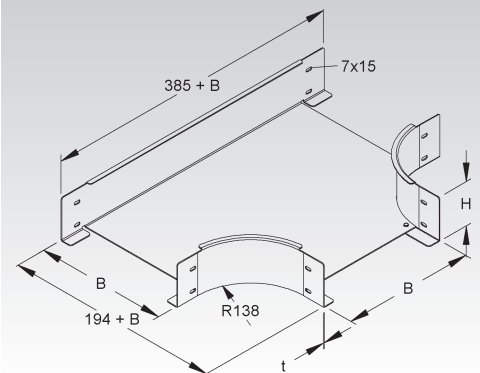

WALKABLE CABLE TRAY SYSTEM

Reducer/Blind End

model no.	height H	width B	width B1	Weight per 100	Pack/Box Qty
	mm Inch	mm Inch	mm Inch	kg	
★ S RA 100.200 S	100 3,9	200 7,9	322 12,7	32,20	20
★ S RA 100.400 S	100 3,9	400 15,7	522 20,6	51,62	20
★ S RA 100.500 S	100 3,9	500 19,7	622 24,5	61,33	20
★ S RA 100.600 S	100 3,9	600 23,6	722 28,4	71,04	20

can be used as blind end or as reducer for cable trays

Height 100 mm
Nominal 4 inches

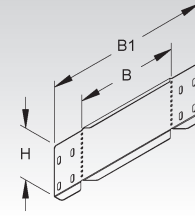

Adjustable Horizontal Splice/Reducer/Blind End

model no.	height H	width B	width B1	Weight per 100	Pack/Box Qty
	mm Inch	mm Inch	mm Inch	kg	
★ S RAW 100.100 S	100 3,9	100 3,9	222 8,7	22,14	20
★ S RAW 100.300 S	100 3,9	300 11,8	422 16,6	41,56	20

can be used as blind end or as reducer for cable trays

Height 100 mm
Nominal 4 inches

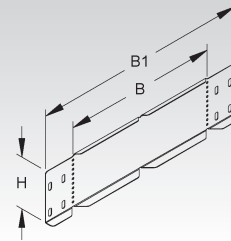

End Plate with Cover Lock

model no.	height H	width B	width B1	Weight per 100 pcs	Pack/Box Qty
	mm Inch	mm Inch	mm Inch	kg	
★ S RADS 100.100 S	107,5 4,2	102 4	222 8,7	20,88	20
★ S RADS 100.200 S	107,5 4,2	202 8	322 12,7	29,82	20
★ S RADS 100.300 S	107,5 4,2	302 11,9	422 16,6	38,75	20
★ S RADS 100.400 S	107,5 4,2	402 15,8	522 20,6	47,69	20
★ S RADS 100.500 S	107,5 4,2	502 19,8	622 24,5	56,63	20
★ S RADS 100.600 S	107,5 4,2	602 23,7	722 28,4	65,57	20

for terminating walkable cable tray, with elevated flange to prevent covers from sliding lengthwise

Height 100 mm
Nominal 4 inches

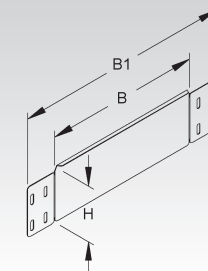

Heavy duty cable tray

with solid sides

model no.	height H	width B	thickness t	Weight per 100 m	Pack/Box Qty
	mm Inch	mm Inch	mm	kg	
S RSQLS 110.100 OV	110 4,3	100 3,9	2	528,04	2 x 3 m
S RSQLS 110.200 OV	110 4,3	200 7,9	2	680,72	2 x 3 m
S RSQLS 110.300 OV	110 4,3	300 11,8	2	833,40	2 x 3 m
S RSQLS 110.400 OV	110 4,3	400 15,7	2	986,08	2 x 3 m
S RSQLS 110.500 OV	110 4,3	500 19,7	2	1.138,75	2 x 3 m
S RSQLS 110.600 OV	110 4,3	600 23,6	2	1.291,43	2 x 3 m

slotted bottom plate for easy divider and floorstand mounting with prepunched holes for splices

Bottom plate with elongated hole pattern for divider and floorstand installation.

RSUV 110-1.5 splice plates are not included.

Height 110 mm
Nominal 4 3/8 inches



66

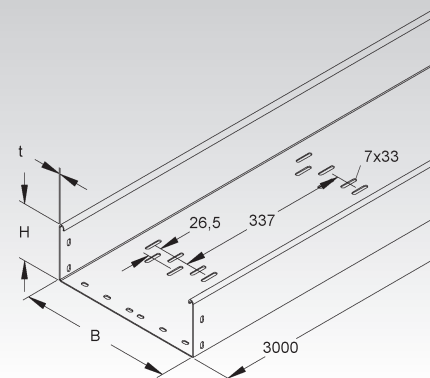

Universal Splice Plate

model no.	height H mm Inch	width B mm Inch	thick-ness t mm	Weight per 100 pcs kg	Pack/Box Qty
S RSUV 110-1.5	102 4	150 5,9	1,5	19,34	50

for straight and angled joints

Height 110 mm
Nominal 4 3/8 inches
51

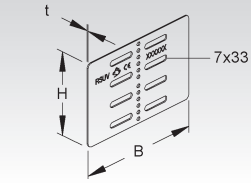

Divider

perforated

model no.	height H mm Inch	thick-ness t mm	Weight per 100 m kg	Pack/Box Qty
S RTSKQ 110-1.5 S	108 4,3	1,5	186,33	3 m
S RTSKQ 110-2.0 S	108 4,3	2,0	247,81	3 m

with elongated mounting holes

Minimum number of dividers required to support the walkable covers:
for cover width 100 and 200 mm = none
for cover width 300 mm and 400 mm = 1 piece with a maximum compartment width of 200 mm
for cover width 500 mm and 600 mm = 2 pieces with a maximum compartment width of 200 mm

Height 110 mm
Nominal 4 3/8 inches
62 63 66

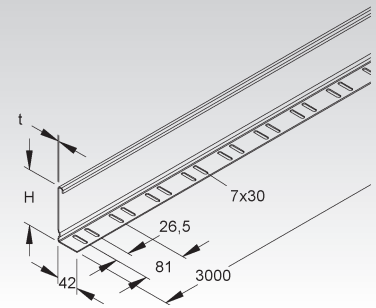

Flexible Divider

with elongated mounting holes

model no.	height H mm Inch	thick-ness t mm	Weight per 100 kg	Pack/Box Qty
S RTSQF 110-1.5/1000 S	108 4,3	1,5	168,72	1 m

segmented for easy horizontal bending

Height 110 mm
Nominal 4 3/8 inches
63

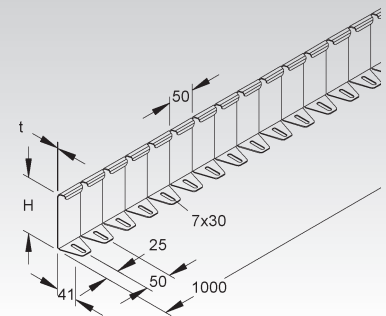

Horizontal Elbow 45°

solid sides with integrated splice plate

model no.	height H mm Inch	inside dimension (B) mm Inch	thick-ness t mm	Weight per 100 pcs kg	Pack/Box Qty
S RBAS 110.100	110 4,3	100 3,9	2	123,69	1
S RBAS 110.200	110 4,3	200 7,9	2	171,12	1
S RBAS 110.300	110 4,3	300 11,8	2	231,56	1
S RBAS 110.400	110 4,3	400 15,7	2	305,01	1
S RBAS 110.500	110 4,3	500 19,7	2	391,47	1
S RBAS 110.600	110 4,3	600 23,6	2	490,93	1

for horizontal 45° deviations

Height 110 mm
Nominal 4 3/8 inches

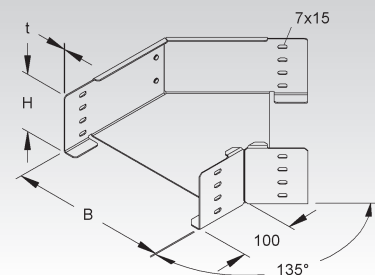

WALKABLE CABLE TRAY SYSTEM

Horizontal Elbow 90°

solid sides with integrated splice plate

	model no.	height H		inside dimension (B)		thick-ness t	Weight per 100 pcs	Pack/Box Qty
		mm	Inch	mm	Inch			
S	RESS 110.100	110	4,3	100	3,9	2	257,42	1
S	RESS 110.200	110	4,3	200	7,9	2	382,77	1
S	RESS 110.300	110	4,3	300	11,8	2	539,51	1
S	RESS 110.400	110	4,3	400	15,7	2	727,66	1
S	RESS 110.500	110	4,3	500	19,7	2	947,20	1
S	RESS 110.600	110	4,3	600	23,6	2	1.198,15	1

for horizontal 90° deviations

Height 110 mm
Nominal 4 3/8 inches

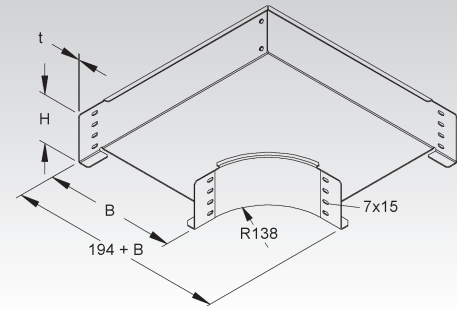

Extension Horizontal Tee

solid sides with integrated splice plate

	model no.	height H		inside dimension (B)		thick-ness t	Weight per 100 pcs	Pack/Box Qty
		mm	Inch	mm	Inch			
S	RTAS 110.100	110	4,3	100	3,9	2	185,74	1
S	RTAS 110.200	110	4,3	200	7,9	2	206,46	1
S	RTAS 110.300	110	4,3	300	11,8	2	227,19	1
S	RTAS 110.400	110	4,3	400	15,7	2	247,91	1
S	RTAS 110.500	110	4,3	500	19,7	2	268,63	1
S	RTAS 110.600	110	4,3	600	23,6	2	289,36	1

for horizontal tee connections of cable trays

Height 110 mm
Nominal 4 3/8 inches

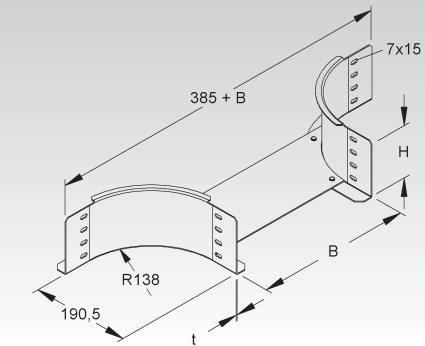

Horizontal Tee

solid sides with integrated splice plate

	model no.	height H		inside dimension (B)		thick-ness t	Weight per 100 pcs	Pack/Box Qty
		mm	Inch	mm	Inch			
S	RTSS 110.100	110	4,3	100	3,9	2	335,42	1
S	RTSS 110.200	110	4,3	200	7,9	2	463,13	1
S	RTSS 110.300	110	4,3	300	11,8	2	622,24	1
S	RTSS 110.400	110	4,3	400	15,7	2	812,74	1
S	RTSS 110.500	110	4,3	500	19,7	2	1.034,68	1
S	RTSS 110.600	110	4,3	600	23,6	2	1.287,96	1

for horizontal tee connections of cable trays with identical width

Height 110 mm
Nominal 4 3/8 inches

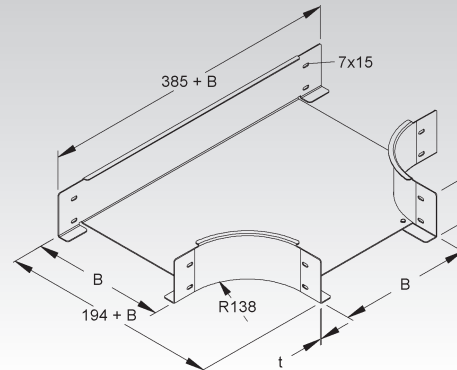

Reducer/Blind End

	model no.	height H		width B		width B1		Weight per 100 pcs/pc.	Pack/Box Qty
		mm	Inch	mm	Inch	mm	Inch		
S	RA 110.200	110	4,3	200	7,9	322	12,7	34,39	20
S	RA 110.400	110	4,3	400	15,7	522	20,6	55,38	20
S	RA 110.600	110	4,3	600	23,6	722	28,4	76,37	20

can be used as blind end or as reducer for cable trays

Height 110 mm
Nominal 4 3/8 inches

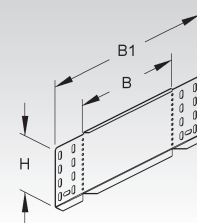

Adjustable Horizontal Splice/Reducer/Blind End

model no.	height H	width B	width B1	Weight per 100 pcs kg	Pack/ Box Qty
	mm Inch	mm Inch	mm Inch		
S RAW 110.100	110 4,3	100 3,9	222 8,7	23,60	20
S RAW 110.300	110 4,3	300 11,8	422 16,6	44,59	20

can be used as blind end or as reducer for cable trays

Height
110
mm

Nominal
4 3/8
inches

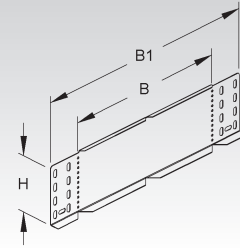

End Plate with Cover Lock

model no.	height H	width B	width B1	Weight per 100 kg	Pack/ Box Qty
	mm Inch	mm Inch	mm Inch		
★ S RADS 110.100 S	117,5 4,6	102 4	222 8,7	22,62	20
★ S RADS 110.200 S	117,5 4,6	202 8	322 12,7	32,34	20
★ S RADS 110.300 S	117,5 4,6	302 11,9	422 16,6	42,06	20
★ S RADS 110.400 S	117,5 4,6	402 15,8	522 20,6	51,79	20
★ S RADS 110.500 S	117,5 4,6	502 19,8	622 24,5	61,51	20
★ S RADS 110.600 S	117,5 4,6	602 23,7	722 28,4	71,23	20

for terminating walkable cable tray, with elevated flange to prevent covers from sliding lengthwise

Height
110
mm

Nominal
4 3/8
inches

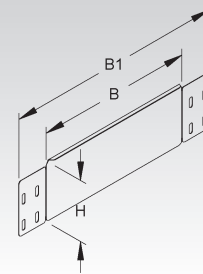

Heavy Duty Cover

model no.	inside dimension (B)	thick- ness t	Weight per 100 m kg	Pack/ Box Qty
	mm Inch	mm		
S RDS 100	105 4,1	2	201,63	2 x 3 m
S RDS 200	205 8,1	2	358,60	2 x 3 m
S RDS 300	305 12	2	515,60	2 x 3 m
S RDS 400	405 15,9	2	672,60	2 x 3 m
S RDS 500	505 19,9	2	829,60	2 x 3 m
S RDS 600	605 23,8	2	986,60	2 x 3 m

Please install the recommended number of RTSKQ... or RTSQF... dividers to support the walkable cover.

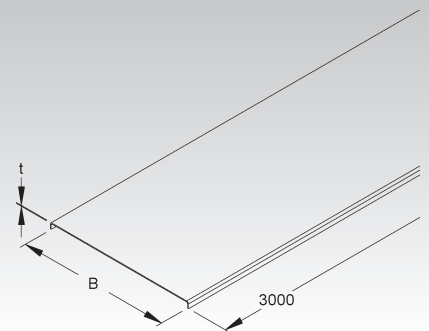

Heavy Duty Cover

with preinstalled turnbolt locks

model no.	inside dimension (B)	thick- ness t	Weight per 100 m kg	Pack/ Box Qty
	mm Inch	mm		
S RDVS 100	105 4,1	2	203,8	2 x 3 m
S RDVS 200	205 8,1	2	360,8	2 x 3 m
S RDVS 300	305 12	2	517,8	2 x 3 m
S RDVS 400	405 15,9	2	674,8	2 x 3 m
S RDVS 500	505 19,9	2	831,8	2 x 3 m
S RDVS 600	605 23,8	2	988,8	2 x 3 m

Please install the recommended number of RTSKQ... or RTSQF... dividers to support the walkable cover.

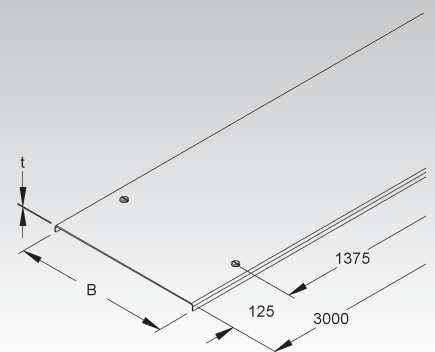

WALKABLE CABLE TRAY SYSTEM

Heavy Duty Antiskid Cover (DIN 51130 class R10)

with embossed notches for turnbolt installation

	model no.	inside dimension (B) mm Inch	thick-ness t mm	Weight per 100 m kg	Pack/ Box Qty
★	S RDRS 100-2.0 S	105 4,1	3,25	201,83	3 m
★	S RDRS 200-2.0 S	205 8,1	3,25	359,11	3 m
★	S RDRS 300-2.0 S	305 12	3,25	516,41	3 m
★	S RDRS 400-2.0 S	405 15,9	3,25	673,70	3 m
★	S RDRS 500-2.0 S	505 19,9	3,25	830,99	3 m
★	S RDRS 600-2.0 S	605 23,8	3,25	988,28	3 m

Please install the recommended number of RTSKQ... or RTSQF... dividers to support the walkable cover.

The nominal thickness "t" includes the diamond pattern.

RDRS 9x2 turnbolt locks are not included.



66

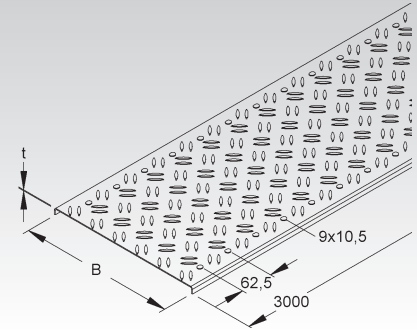

Heavy Duty Aluminium Checker Plate Cover

with preinstalled turnbolt locks

	model no.	inside dimension (B) mm Inch	thick-ness t mm	Weight per 100 m kg	Pack/ Box Qty
	S RDVSRSL 100	105 4,1	4	243,32	3 m
	S RDVSRSL 200	205 8,1	4	440,41	3 m
	S RDVSRSL 300	305 12	4	637,57	3 m
	S RDVSRSL 400	405 15,9	4	834,73	3 m
	S RDVSRSL 500	505 19,9	4	1.031,89	3 m
	S RDVSRSL 600	605 23,8	4	1.229,05	3 m

The nominal thickness "t" includes the diamond pattern.

Please install the recommended number of RTSKQ... or RTSQF... dividers to support the walkable cover.



66

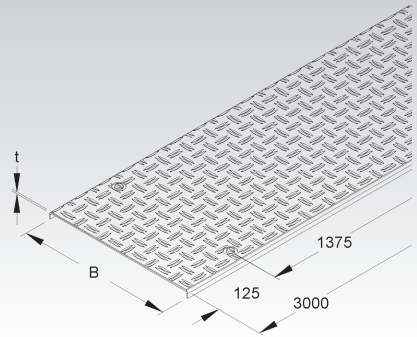

Heavy Duty Cover for 45° Horizontal Elbow

with preinstalled turnbolt locks

	model no.	inside dimension (B) mm Inch	thick-ness t mm	Weight per 100 pcs kg	Pack/ Box Qty
	S RBADVS 100	105 4,1	2	49,77	1
	S RBADVS 200	205 8,1	2	102,68	1
	S RBADVS 300	305 12	2	168,59	1
	S RBADVS 400	405 15,9	2	247,51	1
	S RBADVS 500	505 19,9	2	339,43	1
	S RBADVS 600	605 23,8	2	444,36	1

Please install the recommended number of RTSKQ... or RTSQF... dividers to support the walkable cover.

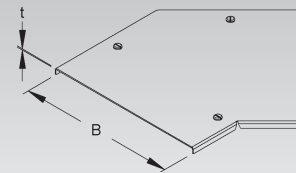

Heavy Duty Antiskid Cover for 45° Horizontal Elbow

with embossed notches for turnbolt installation

	model no.	inside dimension (B) mm Inch	thick-ness t mm	Weight per 100 pcs kg	Pack/ Box Qty
★	S RBADVRS 100-2.0 S	105 4,1	3,25	49,81	1
★	S RBADVRS 200-2.0 S	205 8,1	3,25	102,76	1
★	S RBADVRS 300-2.0 S	305 12	3,25	168,79	1
★	S RBADVRS 400-2.0 S	405 15,9	3,25	247,87	1
★	S RBADVRS 500-2.0 S	505 19,9	3,25	339,93	1
★	S RBADVRS 600-2.0 S	605 23,8	3,25	445,04	1

Please install the recommended number of RTSKQ... or RTSQF... dividers to support the walkable cover.

The nominal thickness "t" includes the diamond pattern.

RDRS 9x2 turnbolt locks are not included.

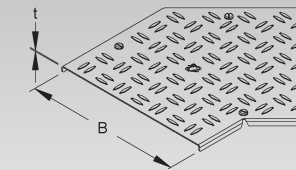

Aluminum Checker Plate Cover for 45° Horizontal Elbow

with preinstalled turnbolt locks

	model no.	inside dimension (B)		thick-ness t	Weight per 100 pcs	Pack/Box Qty
		mm	Inch			
S	RBADVSRSL 100 S	105	4,1	3,5	59,25	1
S	RBADVSRSL 200 S	205	8,1	3,5	125,21	1
S	RBADVSRSL 300 S	305	12	3,5	207,56	1
S	RBADVSRSL 400 S	405	15,9	3,5	306,19	1
S	RBADVSRSL 500 S	505	19,9	3,5	421,15	1
S	RBADVSRSL 600 S	605	23,8	3,5	552,45	1

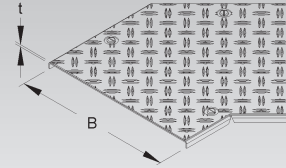

Please install the recommended number of RTSKQ... or RTSQF... dividers to support the walkable cover.

The nominal thickness "t" includes the diamond pattern.

Heavy Duty Cover for 90° Horizontal Elbow

with preinstalled turnbolt locks

	model no.	inside dimension (B)		thick-ness t	Weight per 100 pcs	Pack/Box Qty
		mm	Inch			
S	RESDVS 100	105	4,1	2	103,56	1
S	RESDVS 200	205	8,1	2	215,43	1
S	RESDVS 300	305	12	2	358,69	1
S	RESDVS 400	405	15,9	2	533,35	1
S	RESDVS 500	505	19,9	2	739,42	1
S	RESDVS 600	605	23,8	2	976,88	1

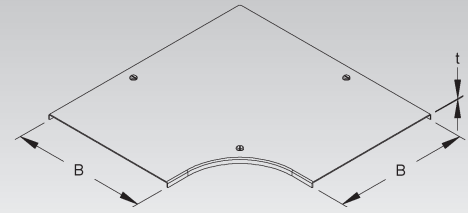

Please install the recommended number of RTSKQ... or RTSQF... dividers to support the walkable cover.

Heavy Duty Antiskid Cover for 90° Horizontal Elbow

with embossed notches for turnbolt installation

	model no.	inside dimension (B)		thick-ness t	Weight per 100 pcs	Pack/Box Qty
		mm	Inch			
★ S	RESDVRS 100-2.0 S	105	4,1	3,25	99,34	1
★ S	RESDVRS 200-2.0 S	205	8,1	3,25	211,39	1
★ S	RESDVRS 300-2.0 S	305	12	3,25	354,91	1
★ S	RESDVRS 400-2.0 S	405	15,9	3,25	529,88	1
★ S	RESDVRS 500-2.0 S	505	19,9	3,25	736,30	1
★ S	RESDVRS 600-2.0 S	605	23,8	3,25	974,24	1

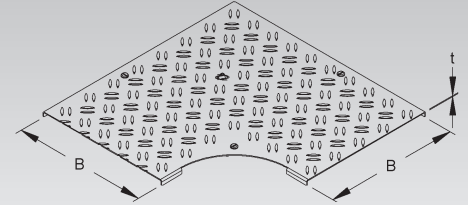

Please install the recommended number of RTSKQ... or RTSQF... dividers to support the walkable cover.

The nominal thickness "t" includes the diamond pattern.

RDRS 9x2 turnbolt locks are not included.

Aluminum Checker Plate Cover for 90° Horizontal Elbow

with preinstalled turnbolt locks

	model no.	inside dimension (B)		thick-ness t	Weight per 100 pcs	Pack/Box Qty
		mm	Inch			
S	RESDVSRSL 100	105	4,1	3,5	124,52	1
S	RESDVSRSL 200	205	8,1	3,5	263,86	1
S	RESDVSRSL 400	405	15,9	3,5	660,85	1
S	RESDVSRSL 300	305	12	3,5	442,63	1
S	RESDVSRSL 500	505	19,9	3,5	918,49	1
S	RESDVSRSL 600	605	23,8	3,5	1.215,57	1

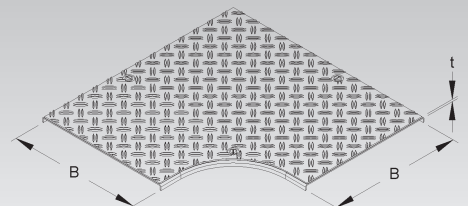

Please install the recommended number of RTSKQ... or RTSQF... dividers to support the walkable cover.

The nominal thickness "t" includes the diamond pattern.

WALKABLE CABLE TRAY SYSTEM

Heavy Duty Cover for Horizontal Extension Tee

with preinstalled turnbolt locks

	model no.	inside dimension (B) mm Inch	thick-ness t mm	Weight per 100 pcs kg	Pack/ Box Qty
S	RTADVS 100	105 4,1	2	55,89	1
S	RTADVS 200	205 8,1	2	86,20	1
S	RTADVS 300	305 12	2	116,50	1
S	RTADVS 400	405 15,9	2	146,80	1
S	RTADVS 500	505 19,9	2	177,10	1
S	RTADVS 600	605 23,8	2	207,40	1

Please install the recommended number of RTSKQ... or RTSQF... dividers to support the walkable cover.

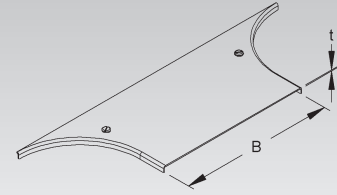

Heavy Duty Antiskid Cover for Horizontal Extension Tee

with embossed notches for turnbolt installation

	model no.	inside dimension (B) mm Inch	thick-ness t mm	Weight per 100 kg	Pack/ Box Qty
★ S	RTADVRS 100-2.0 S	105 4,1	3,25	53,64	1
★ S	RTADVRS 200-2.0 S	205 8,1	3,25	84,99	1
★ S	RTADVRS 300-2.0 S	305 12	3,25	116,34	1
★ S	RTADVRS 400-2.0 S	405 15,9	3,25	147,69	1
★ S	RTADVRS 500-2.0 S	505 19,9	3,25	179,04	1
★ S	RTADVRS 600-2.0 S	605 23,8	3,25	210,39	1

Please install the recommended number of RTSKQ... or RTSQF... dividers to support the walkable cover.

The nominal thickness "t" includes the diamond pattern.

RDRS 9x2 turnbolt locks are not included.

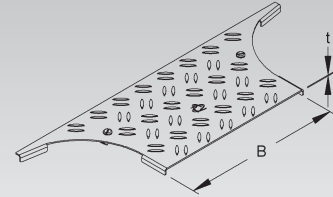

Aluminum Checker Plate Cover for Horizontal Extension Tee

with preinstalled turnbolt locks

	model no.	width B mm Inch	thick-ness t mm	Weight per 100 pcs kg	Pack/ Box Qty
S	RTADVSRSL 100	105 4,1	3,5	66,56	1
S	RTADVSRSL 200	205 8,1	3,5	104,58	1
S	RTADVSRSL 300	305 12	3,5	142,59	1
S	RTADVSRSL 400	405 15,9	3,5	180,61	1
S	RTADVSRSL 500	505 19,9	3,5	218,62	1
S	RTADVSRSL 600	605 23,8	3,5	256,63	1

Please install the recommended number of RTSKQ... or RTSQF... dividers to support the walkable cover.

The nominal thickness "t" includes the diamond pattern.

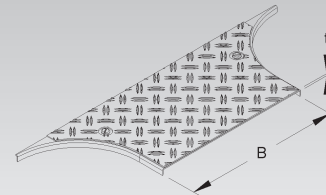

Heavy Duty Cover for Horizontal Tee

with preinstalled turnbolt locks

	model no.	inside dimension (B) mm Inch	thick-ness t mm	Weight per 100 pcs kg	Pack/ Box Qty
S	RTSDVS 100	105 4,1	2	146,05	1
S	RTSDVS 200	205 8,1	2	286,45	1
S	RTSDVS 300	305 12	2	458,25	1
S	RTSDVS 400	405 15,9	2	661,45	1
S	RTSDVS 500	505 19,9	2	896,05	1
S	RTSDVS 600	605 23,8	2	1.162,04	1

Please install the recommended number of RTSKQ... or RTSQF... dividers to support the walkable cover.

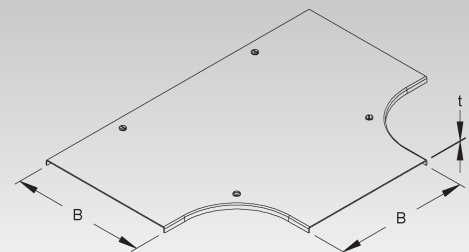

Aluminum Checker Plate Cover for Horizontal Tee

with embossed notches for turnbolt installation

	model no.	inside dimension (B) mm Inch	thick-ness t mm	Weight per 100 pcs kg	Pack/ Box Qty
★	S RTSDVRS 100-2.0 S	105 4,1	3,25	137,24	1
★	S RTSDVRS 200-2.0 S	205 8,1	3,25	277,56	1
★	S RTSDVRS 300-2.0 S	305 12	3,25	449,36	1
★	S RTSDVRS 400-2.0 S	405 15,9	3,25	652,59	1
★	S RTSDVRS 500-2.0 S	505 19,9	3,25	887,33	1
★	S RTSDVRS 600-2.0 S	605 23,8	3,25	1.153,49	1

Please install the recommended number of RTSKQ... or RTSQF... dividers to support the walkable cover.

The nominal thickness "t" includes the diamond pattern.

RDRS 9x2 turnbolt locks are not included.

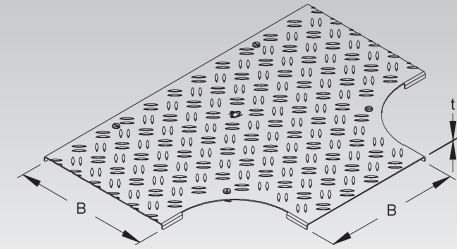

Aluminum Checker Plate Cover for Horizontal Tee

with preinstalled turnbolt locks

	model no.	inside dimension (B) mm Inch	thick-ness t mm	Weight per 100 pcs kg	Pack/ Box Qty
	S RTSDVSRSL 100	105 4,1	3,5	176,38	1
	S RTSDVSRSL 200	205 8,1	3,5	352,09	1
	S RTSDVSRSL 300	305 12	3,5	567,24	1
	S RTSDVSRSL 400	405 15,9	3,5	821,81	1
	S RTSDVSRSL 500	505 19,9	3,5	1.115,82	1
	S RTSDVSRSL 600	605 23,8	3,5	1.449,27	1

Please install the recommended number of RTSKQ... or RTSQF... dividers to support the walkable cover.

The nominal thickness "t" includes the diamond pattern.

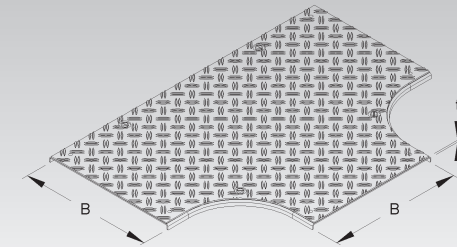

Heavy Duty Turnbolt Lock

locking nut included

	model no.	thick-ness t mm	Weight per 100 pcs kg	Pack/ Box Qty
	S RDRS 9X2	2	2,1	20

Suitable for: RDS..., RDSV..., RDRS... and RDVSRSL... covers

Not sufficient for securing covers to tray installed vertically or sideways nor for securing covers against windloads. Please use self tapping screws, steel cable ties or cover-hinges in addition.

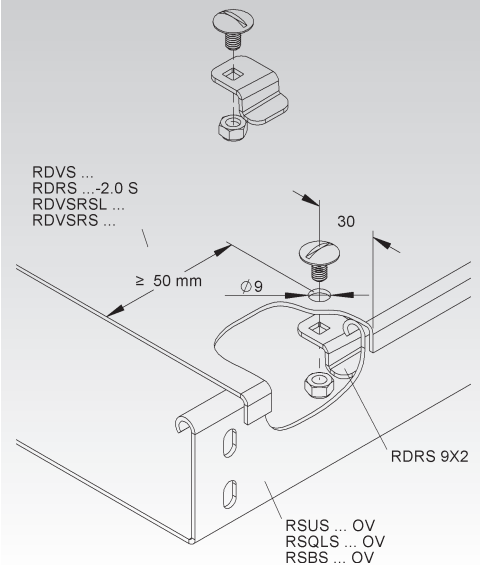
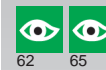

Turnbolt Lock

	model no.	Weight per 100 pcs kg	Pack/ Box Qty
	E3 RDRS 2 E3	1,5	100

Suitable for: all R-series fitting covers

Not sufficient for securing covers to tray installed vertically or sideways nor for securing covers against windloads. Please use self tapping screws, steel cable ties or cover-hinges in addition.



WALKABLE CABLE TRAY SYSTEM

Heavy Duty Cover Clamp

model no.	Weight per 100 pcs kg	Pack/Box Qty
V RDHFS 9 V	0,92	60

Suitable for: RDS..., RDSV..., RDRS... and RDVSRSL... covers
 Not sufficient for securing covers to tray installed vertically or sideways nor for securing covers against windloads. Please use self tapping screws, steel cable ties or cover-hinges in addition.

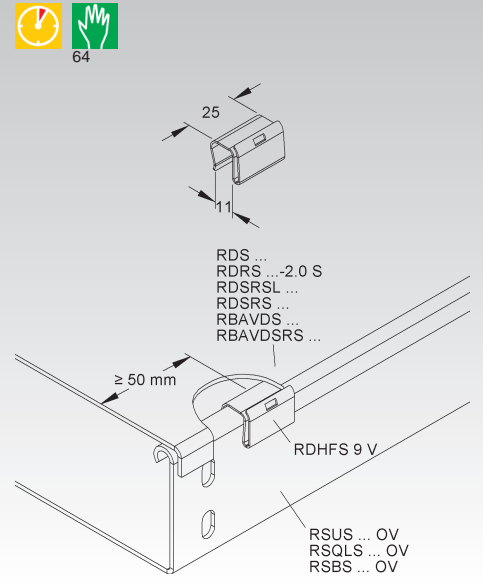

Floor Mounting Bracket (height: 50 mm)

with slotted holes

model no.	height H	width B	thickness t	Weight per 100 pcs kg	Pack/Box Qty
	mm Inch	mm Inch	mm		
S RZP 50/100	50 2	100 3,9	2	18,19	10
S RZP 50/200	50 2	200 7,9	2	34,51	10
S RZP 50/300	50 2	300 11,8	2	50,82	10
S RZP 50/400	50 2	400 15,7	2	67,14	10
S RZP 50/500	50 2	500 19,7	2	83,46	10
S RZP 50/600	50 2	600 23,6	2	99,78	10

Alternate mounting of Z-shaped bracket is highly recommended.

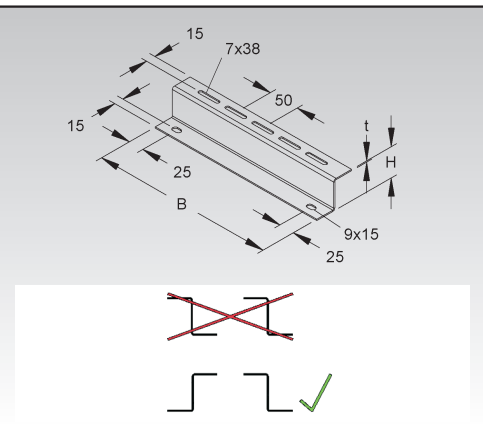

Floor Mounting Bracket (height: 80 mm)

with slotted holes

model no.	height H	width B	thickness t	Weight per 100 pcs kg	Pack/Box Qty
	mm Inch	mm Inch	mm		
S RZP 80/100	80 3,1	100 3,9	2	20	10
S RZP 80/200	80 3,1	200 7,9	2	41	10
S RZP 80/300	80 3,1	300 11,8	2	61	10
S RZP 80/400	80 3,1	400 15,7	2	82	10
S RZP 80/500	80 3,1	500 19,7	2	102	10
S RZP 80/600	80 3,1	600 23,6	2	122	10

Alternate mounting of Z-shaped bracket is highly recommended.

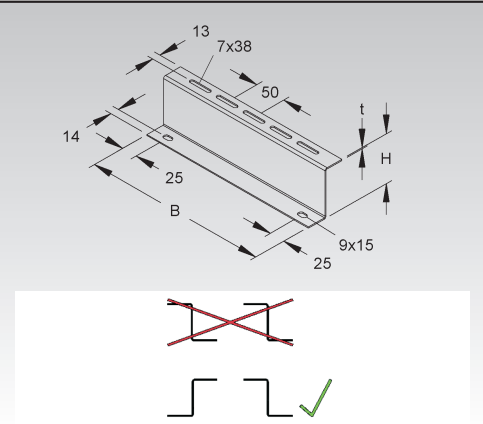

Floor Mounting Bracket (height: 100 mm)

with slotted holes

model no.	height H		width B		thick-ness t	Weight per 100	Pack/Box Qty
	mm	Inch	mm	Inch			
★ S RZP 100/100 S	102	4	100	3,9	2	25,68	10
★ S RZP 100/200 S	102	4	200	7,9	2	49,66	10
★ S RZP 100/300 S	102	4	300	11,8	2	73,64	10
★ S RZP 100/400 S	102	4	400	15,7	2	97,63	10
★ S RZP 100/500 S	102	4	500	19,7	2	121,61	10
★ S RZP 100/600 S	102	4	600	23,6	2	145,60	10
★ S RZP 100/3000 S	102	4	3000	118,1	2	718,53	1

Alternate mounting of Z-shaped bracket is highly recommended.

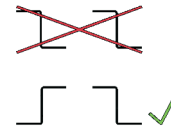
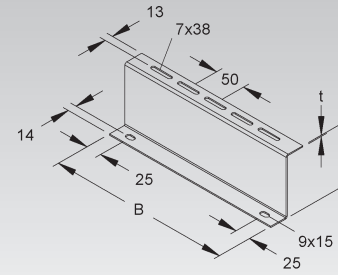

Floor Mounting Bracket (height: 110 mm)

with slotted holes

model no.	height H		width B		thick-ness t	Weight per 100 pcs	Pack/Box Qty
	mm	Inch	mm	Inch			
★ S RZP 110/100 S	110	4,3	100	3,9	2	27,46	10
★ S RZP 110/200 S	110	4,3	200	7,9	2	53,21	10
★ S RZP 110/300 S	110	4,3	300	11,8	2	78,97	10
★ S RZP 110/400 S	110	4,3	400	15,7	2	104,73	10
★ S RZP 110/500 S	110	4,3	500	19,7	2	130,49	10
★ S RZP 110/600 S	110	4,3	600	23,6	2	156,25	10
★ S RZP 110/3000 S	110	4,3	3000	118,1	2	755,80	1

Alternate mounting of Z-shaped bracket is highly recommended.

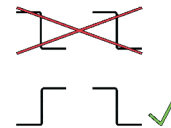
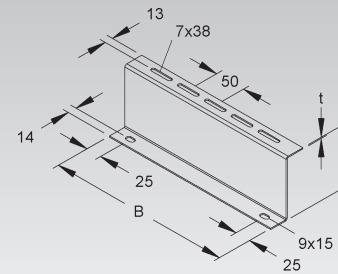

Floor Stand (height: 85 mm)

model no.	height H		width B		length A		thick-ness t	Weight per 100	Pack/Box Qty
	mm	Inch	mm	Inch	mm	Inch			
★ V RDB 85.100 V	85	3,3	100	3,9	50	2	5	60,3	1
★ V RDB 85.200 V	85	3,3	200	7,9	40	1,6	5	62,1	1
★ V RDB 85.300 V	85	3,3	300	11,8	40	1,6	5	77,8	1
★ V RDB 85.400 V	85	3,3	400	15,7	40	1,6	5	93,5	1
★ V RDB 85.500 V	85	3,3	500	19,7	40	1,6	5	109,2	1
★ V RDB 85.600 V	85	3,3	600	23,6	40	1,6	5	124,9	1

▲ Height 85 mm
▼ Nominal 3 3/8 inches
66

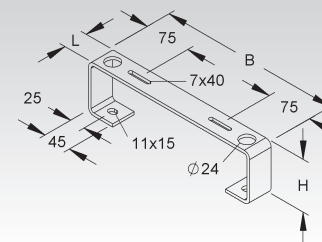

Skirting Panel

model no.	height H		width B		length A		thick-ness t	Weight per 100	Pack/Box Qty
	mm	Inch	mm	Inch	mm	Inch			
★ S VBASB 92.8-1.5/3000 S	92	3,6	8,5	0,3	3000	118,1	1,5	115,27	3 m

Suitable for: RDB 85... floor stands

66

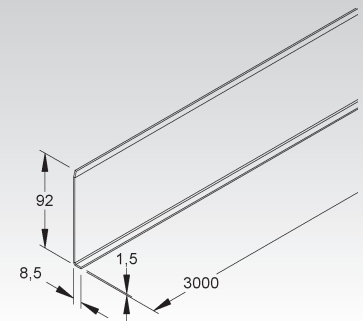

WALKABLE CABLE TRAY SYSTEM

Floor Stand

asymmetric, solid channel with closed ends

	model no.	height H		width B		A	C	Weight per 100	Pack/Box Qty
		mm	Inch	mm	Inch				
★	V RSSTAU 108.100 V	108	4,3	92	3,6	9	63	89,40	1
★	V RSSTAU 108.200 V	108	4,3	192	7,6	9	163	105,90	1
★	V RSSTAU 108.300 V	108	4,3	292	11,5	21	231	122,56	1
★	V RSSTAU 108.400 V	108	4,3	392	15,4	21	331	139,33	1
★	V RSSTAU 108.500 V	108	4,3	492	19,4	121	331	156,11	1
★	V RSSTAU 108.600 V	108	4,3	592	23,3	221	331	172,88	1



62 66

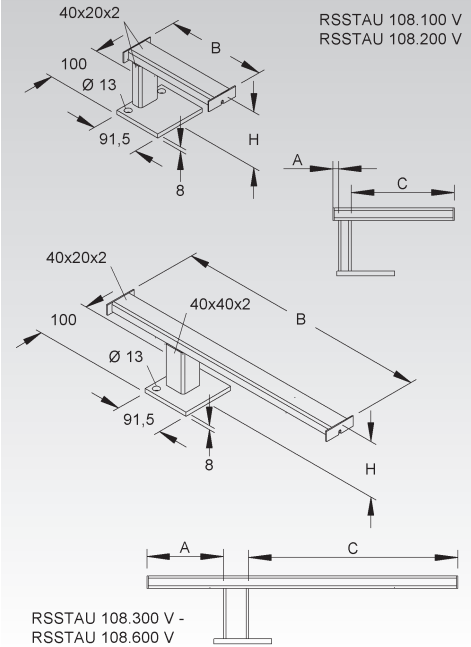

Floor Stand

asymmetric, solid channel with closed ends

	model no.	height H		width B		Weight per 100 pc.	Pack/Box Qty
		mm	Inch	mm	Inch		
F	RSSTAA 108.100	108	4,3	92	3,6	98,29	1
F	RSSTAA 108.200	108	4,3	192	7,6	116,36	1
F	RSSTAA 108.300	108	4,3	292	11,5	134,82	1
F	RSSTAA 108.400	108	4,3	392	15,4	153,26	1
F	RSSTAA 108.500	108	4,3	492	19,4	171,72	1
F	RSSTAA 108.600	108	4,3	592	23,3	190,17	1



66

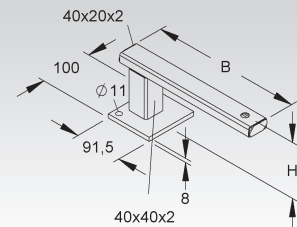

For width 500 and 600 mm the installation of support member RSSTAAS 88 is highly recommended.

Skirting Panel

	model no.	height H		width B		length A		thick-ness t	Weight per 100	Pack/Box Qty
		mm	Inch	mm	Inch	mm	Inch			
★	S VBASB 106.7-2.0/3000 S	106	4,2	7	0,3	3000	118,1	2	172,59	3 m

Suitable for: RSSTAA 108... and RSSTAU 108... floor stands



66

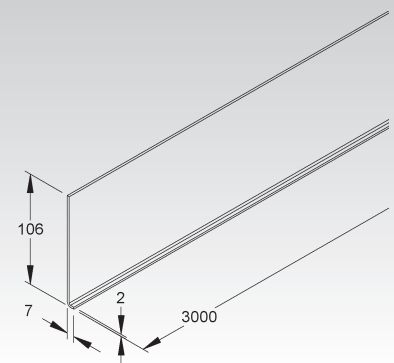

Floor Stand

model no.	height H	width B	width B1	Weight per 100	Pack/Box Qty
	mm Inch	mm Inch	mm Inch	kg	
★ V GRBS 42.100 V	42 1,7	95 3,7	171 6,7	17,84	1
★ V GRBS 42.200 V	42 1,7	195 7,7	271 10,7	25,74	1
★ V GRBS 42.300 V	42 1,7	295 11,6	371 14,6	33,63	1
★ V GRBS 42.400 V	42 1,7	395 15,6	471 18,5	41,52	1
★ V GRBS 42.500 V	42 1,7	495 19,5	571 22,5	52,51	1
★ V GRBS 42.600 V	42 1,7	595 23,4	671 26,4	60,40	1

Please use GTL 30... square washers in combination with FLM 6x20... bolts to install walkable tray on GRBS... floorstands.

GRBS 42.100 - 400

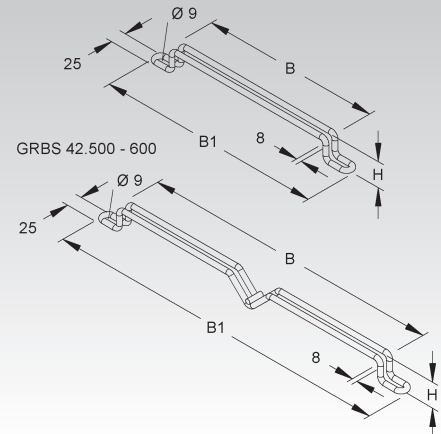

GRBS 85.100 - 400

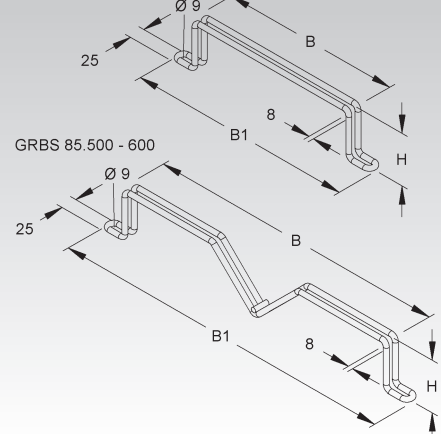

Floor Stand

model no.	height H	width B	width B1	Weight per 100	Pack/Box Qty
	mm Inch	mm Inch	mm Inch	kg	
★ V GRBS 85.100 V	85 3,3	95 3,7	171 6,7	24,63	1
★ V GRBS 85.200 V	85 3,3	195 7,7	271 10,7	32,52	1
★ V GRBS 85.300 V	85 3,3	295 11,6	371 14,6	40,41	1
★ V GRBS 85.400 V	85 3,3	395 15,6	471 18,5	48,31	1
★ V GRBS 85.500 V	85 3,3	495 19,5	571 22,5	62,11	1
★ V GRBS 85.600 V	85 3,3	595 23,4	671 26,4	70,00	1

Please use GTL 30... square washers in combination with FLM 6x20... bolts to install walkable tray on GRBS... floorstands.

Mushroom Head Bolt

serrated flange nut included

model no.	thread M	length A	strength category	Weight per 100 pcs	Pack/Box Qty
		mm Inch		kg	
V FLM 6X12	6	12 0,5	-	0,92	100



Mushroom Head Bolt

serrated flange nut included

model no.	thread M	length A	strength category	Weight per 100	Pack/Box Qty
		mm Inch		kg	
G FLM 6X20 G	6	20 0,8	-	0,9	100



Rounded Head Torx Bolt

serrated flange nut included

model no.	thread M	length A	strength category	Weight per 100	Pack/Box Qty
		mm Inch		kg	
★ V LFM 6X16-TX V	6	16 0,6	-	0,88	50



Self-Tapping Screw

model no.	thread M	length A	strength category	Weight per 100	Pack/Box Qty
		mm Inch		kg	
★ V B 4.2X13-TX V	4,2	13 0,5	-	0,18	1000



WALKABLE CABLE TRAY SYSTEM

U-Shaped Square Washer

model no.	Weight per 100 kg	Pack/Box Qty
V GTL 30 V	1,5	50

Use GTL 20 and GTL 30 with FLM 6X20 as heavy duty splicekit.

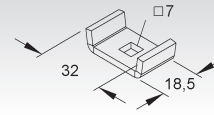
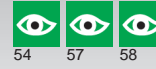

Nail Anchor

model no.	thread M	clamping range mm	Weight per 100 pcs kg	Pack/Box Qty
V DAM 6X5	6	≤ 5	1,38	50
V DAM 6X10	6	≤ 10	1,30	50



Bolt Anchor

model no.	thread M	clamping range mm	Weight per 100 pcs kg	Pack/Box Qty
V DAZ 8X10	8	≤ 10	3,16	50
V DAZ 10X10	10	≤ 10	6,33	50

High performance steel anchor with washer and nut for cracked and non/cracked concrete (C20/25 to C50/60) as well as for natural stone with dense structure.

Please always follow the installation instructions and contact Niedax with any questions regarding technical specifications.

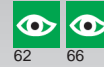

NOTES

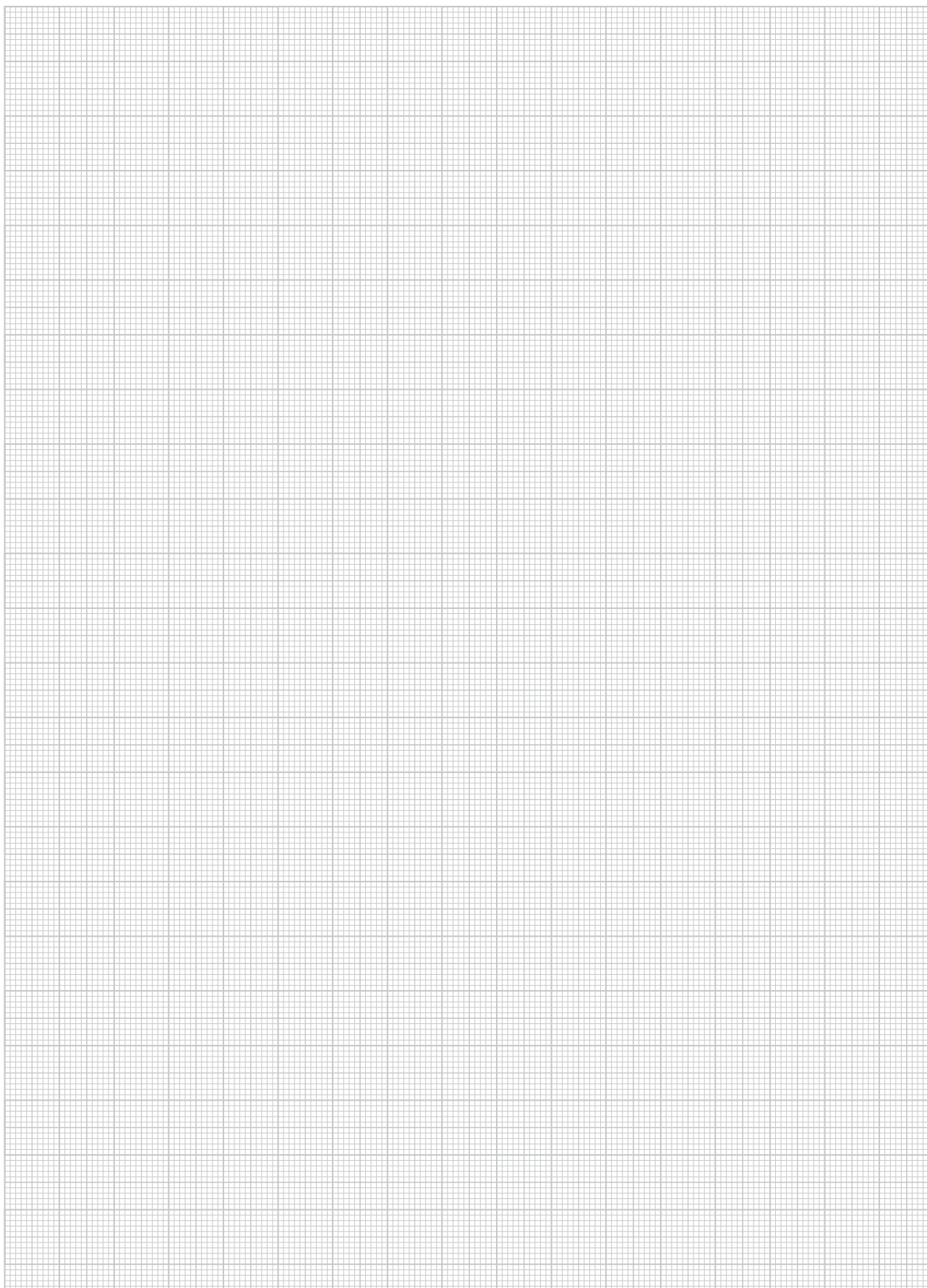
A large rectangular area filled with a fine grid of light gray lines, intended for taking notes. The grid covers most of the page's width and height.

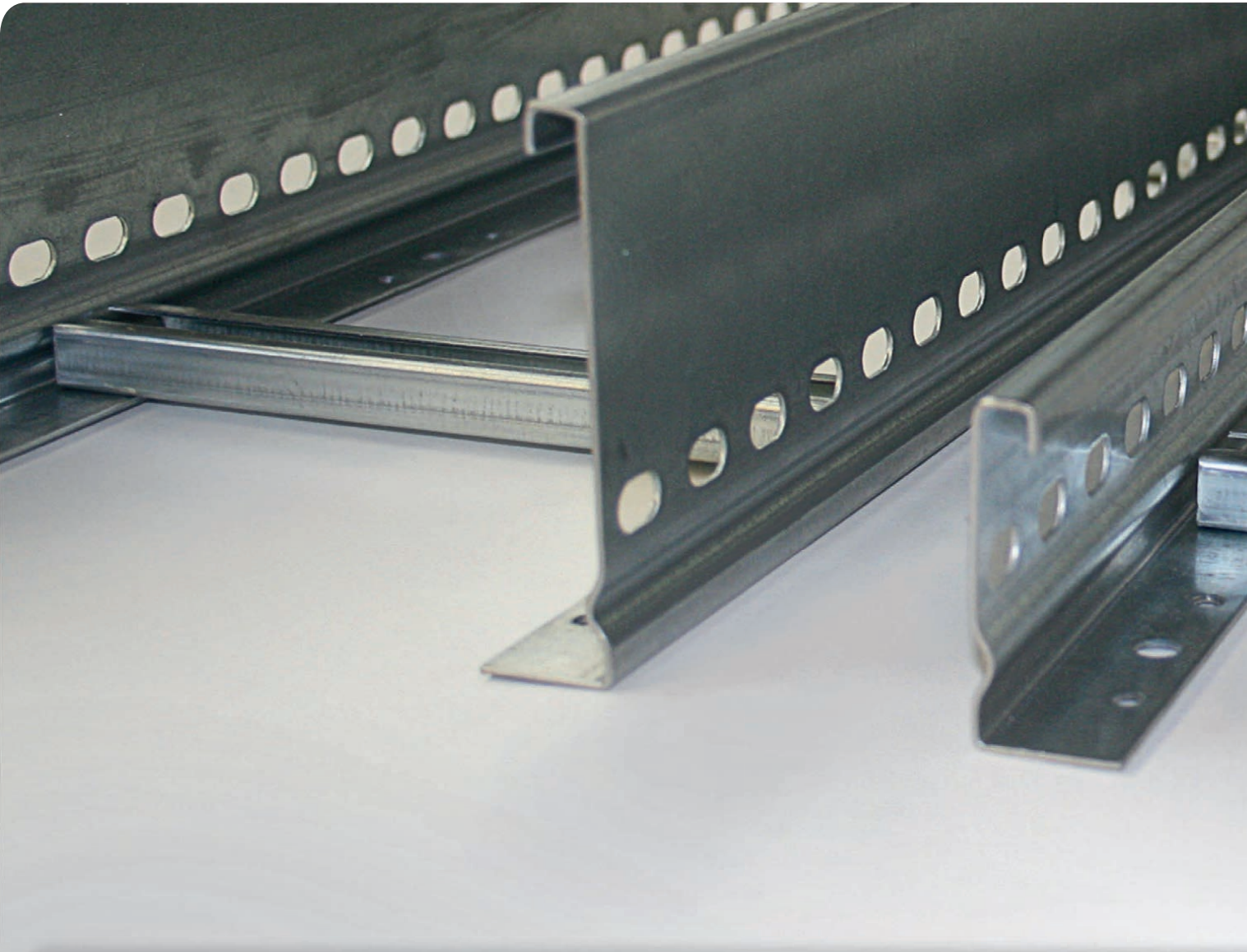

CABLE LADDER SYSTEM

- Cable Ladder
- Covers
- Fittings
- Accessoires



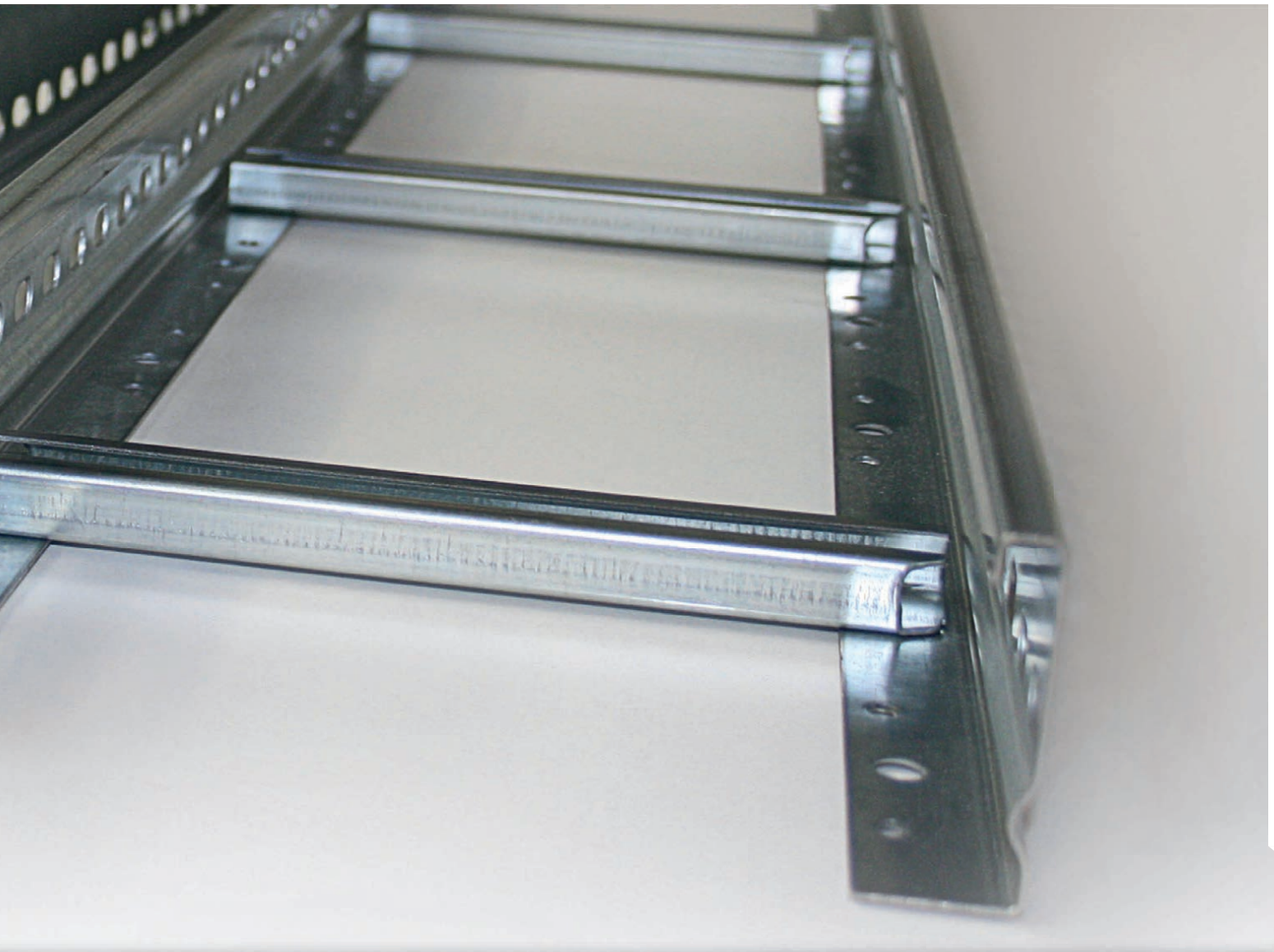

Cable ladders are ideal to install large volumes of heavy duty power cables. The long rung spacing means full free air rating of cables. Higher current flow can be achieved at the same cable cross-section. Overheating and consecutive damaging of cables is avoided. The new shape of the side rail allows higher cable loads at similar support spans, the continuous perforation in the siderails guarantees easy mounting of fittings. Cables can be installed and fixed to the rungs using appropriate yoke clamps. Niedax Cable ladders can be slit together to minimize transport and storage volume needs.

CABLE LADDER SYSTEM

Available Side Rail Heights



SYSTEM			
	Cable Ladder	KL...	Page 246
ZUBEHÖR	Splice Plate	KSV...	Page 246
	Adjustable Splice Plate	KGV...	Page 246
	Adjustable Splice Plate	KWV...	Page 247
	Barrier Strip	RW 85...	Page 247
	Splice Plate for Barrier Strip	RTV 85 E2	Page 247
	Mounting Clamp for Barrier Strip	KLWC 11...	Page 247
	Horizontal Elbow 90°, small radius	KLBK...	Page 248
	Horizontal Elbow 90°, large radius	KLBG...	Page 248
	Extension Horizontal Tee	KLTA...	Page 249
	Horizontal Tee	KLT...	Page 249
	Horizontal Cross	KLK...	Page 249
	Adjustable Vertical Elbow	KGS...	Page 250
	Cable Ladder Connection Bracket	KLAS 100	Page 250
	Pair of Protective End Caps	SKK 100	Page 250
	Ladder Drop Out	KLAB...	Page 250
	Cable Ladder Mounting Bracket	KLTB 6...	Page 251
	Two Hole Corner Angle	WWU...	Page 251
	Three Hole Corner Angle	WWA...	Page 251
	Cover for Cable Tray/Ladder	RDV...	Page 252
	Cover for 90° Horizontal Elbow, small radius	KLBKDV...	Page 252
	Cover for Horizontal Tee	KLTDV...	Page 252
	Turnbolt Lock	RDRS...	Page 253



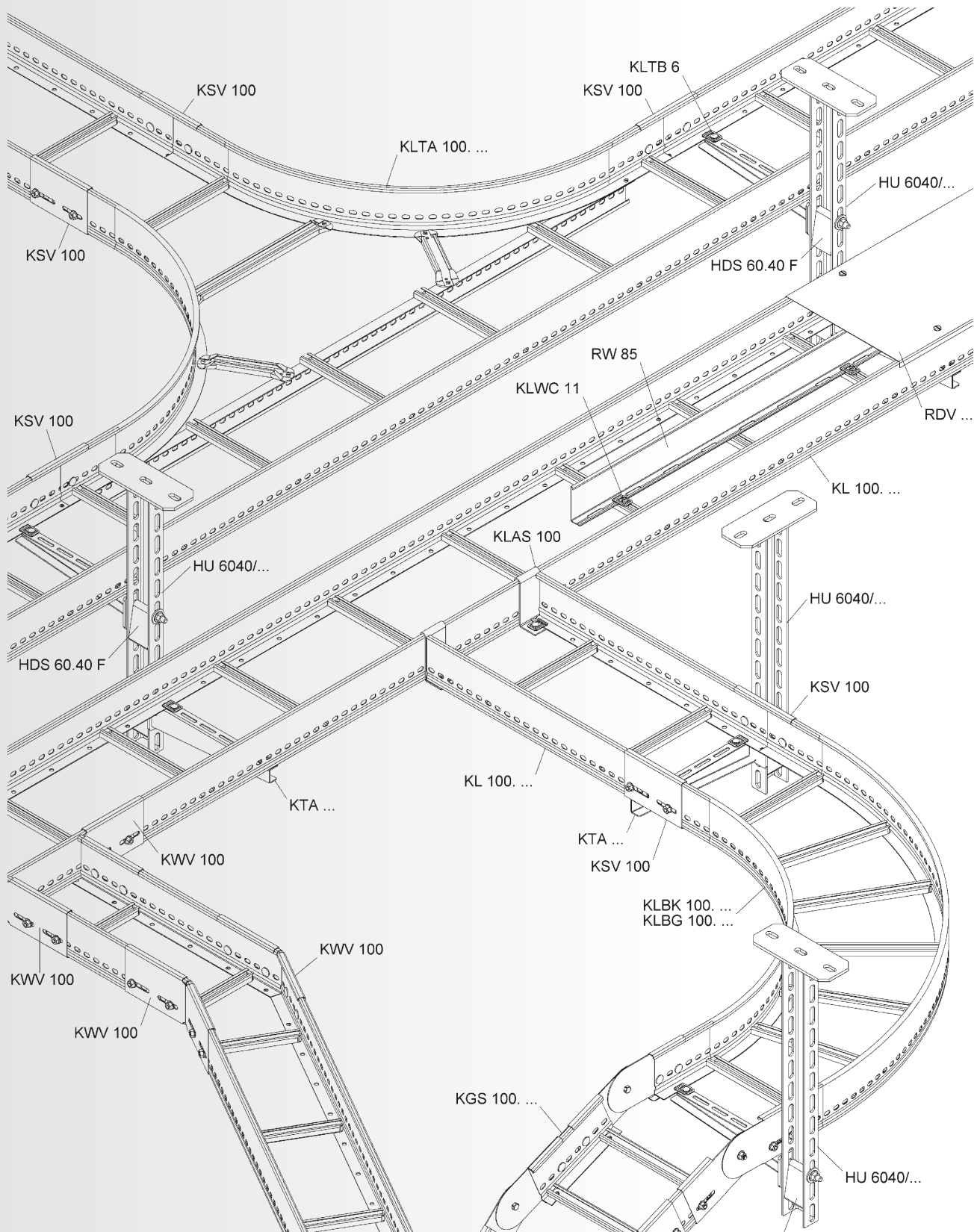

Cable Ladder Specifications:

➔ A. CABLE TRAY DESIGN

1. Cable Tray shall be made of straight sections, fittings and accessories as defined in the latest NEMA standards per NEMA VE-1. Standard cable trays shall be UL classified as equipment grounding conductors.

➔ B. MATERIAL

1. **Pre-galvanized steel.** The structural quality of the steel shall meet the minimum yield and tensile strength of the ASTM standards (ASTM A 653) with G 90 coating thickness.
All cable trays to be labeled for material identification purposes.
2. **Hot dipped galvanized steel.** All trays to be hot-dipped galvanized in accordance with ASTM A123.
All trays to be labeled for material identification.
3. **Stainless steel.** All trays are to be constructed of AISA type 304 or 316 stainless steel.
All trays to be labeled for material identification.

➔ C. TRAY TYPES

1. **Ladder cable tray.** Ladder shall consist of two side-rails with rungs riveted to the bottom flange of the side-rails.
Rungs shall be spaced 8" or 12" (200 or 300 mm) on center. Rungs shall not protrude below the bottom of the side-rail.

➔ D. TRAY SIZE

1. **Height:** Ladder shall have an overall height of 4" (100 mm).
Minimum load depth shall be 3.5" (90 mm).
2. **Width:** Widths shall be 8", 12", 16", 20" and 24" (200, 300, 400, 500 and 600 mm)
3. **Length:** Length shall be a nominal 10' or 3 meters and 20' or 6 meters

➔ E. ACCESSORIES

1. **Covers.** Covers shall be supplied to protect tray cable where needed. Covers will be solid and contain three pair of turn-bolt locks to secure the covers to the lips of the cable tray, requiring only the use of a slotted screwdriver.
2. **Splice plates.** Splice plates shall fasten to the outside of the cable tray side-rails and wrap around and snap onto each section of tray. Bolts and nuts are used to fasten to the tray and are included with splice plates.
Plates shall not exceed the NEMA VE-1 resistance of 330 micro ohms.
3. **Other accessories** shall be furnished as required to protect, support, and install a cable tray system.
Fittings shall made of the same material as the cable tray whenever possible.
Fittings can be of factory construction or also be of a type that allows field constructed fittings.

➔ F. LOADING CAPABILITIES

1. Cable tray shall meet the load/span class designation in accordance with NEMA VE 1 and CSA E22.2 No 126.1.
Cable tray shall also meet load/span designation in accordance with IEC 61537

➔ G. DESIGN AND MANUFACTURE

1. Cable tray design shall be manufactured by The Niedax Group.



➔ **Load/Span Class Designation in accordance with NEMA VE 1 and CSA E22.2 No. 126.1**

Niedax Series	Minimum Area		Load class in accordance to NEMA VE 1		
	(calculational) mm ² / in. ²	in accordance to NEMA VE 2 mm ² / in. ²	Rated Load Kg/m / lb./ft.	Support spacing m / ft.	Load/Span Class
KLX 100.203	414.0 / 0.64	258 / 0.4	107 / 72	2 / 6.6	8A, A
KLX 100.303	414.0 / 0.64	258 / 0.4	107 / 72	2 / 6.6	8A, A
KLX 100.403	414.0 / 0.64	258 / 0.4	107 / 72	2 / 6.6	8A, A
KLX 100.503	414.0 / 0.64	258 / 0.4	107 / 72	2 / 6.6	8A, A
KLX 100.603	414.0 / 0.64	258 / 0.4	107 / 72	2 / 6.6	8A, A
KLX 100.203 F	414.0 / 0.64	258 / 0.4	107 / 72	2 / 6.6	8A, A
KLX 100.303 F	414.0 / 0.64	258 / 0.4	107 / 72	2 / 6.6	8A, A
KLX 100.403 F	414.0 / 0.64	258 / 0.4	107 / 72	2 / 6.6	8A, A
KLX 100.503 F	414.0 / 0.64	258 / 0.4	107 / 72	2 / 6.6	8A, A
KLX 100.603 F	414.0 / 0.64	258 / 0.4	107 / 72	2 / 6.6	8A, A



CABLE LADDER SYSTEM.....

Cable Ladder

C-channel rungs with 11 mm slot width, standard spacing 300 mm

	model no.	height H		width B		thick-ness t	length A		Weight per 100 m	Pack/Box Qty
		mm	Inch	mm	Inch		mm	Inch		
S	KL 100.203	100	3,9	200	7,9	1,5	6000	236,2	350,70	6 m
S	KL 100.303	100	3,9	300	11,8	1,5	6000	236,2	370,50	6 m
S	KL 100.403	100	3,9	400	15,7	1,5	6000	236,2	390,20	6 m
S	KL 100.503	100	3,9	500	19,7	1,5	6000	236,2	409,90	6 m
S	KL 100.603	100	3,9	600	23,6	1,5	6000	236,2	429,60	6 m
F	KL 100.203 F	100	3,9	200	7,9	1,5	6000	236,2	386,98	6 m
F	KL 100.303 F	100	3,9	300	11,8	1,5	6000	236,2	371,50	6 m
F	KL 100.403 F	100	3,9	400	15,7	1,5	6000	236,2	391,30	6 m
F	KL 100.503 F	100	3,9	500	19,7	1,5	6000	236,2	411,00	6 m
F	KL 100.603 F	100	3,9	600	23,6	1,5	6000	236,2	473,79	6 m

KSV 100... splice plates have to be ordered separately.
Cable ladder is available in 3 meter length as well.

Load Chart: q = uniformly distributed load (tested according to DIN EN IEC 61537 standard)

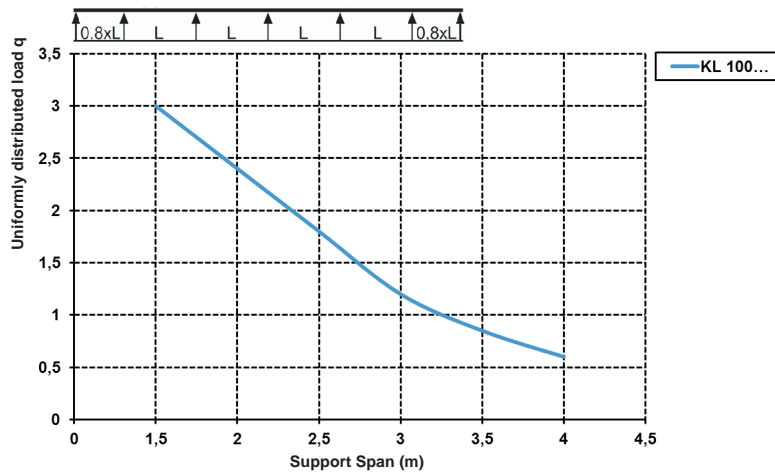

Specified load ratings are independent of splice plate location.

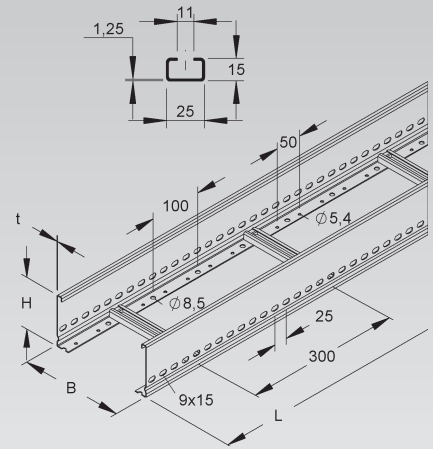
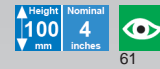

Splice Plate

	model no.	height H		Weight per 100 pcs	Pack/Box Qty
		mm	Inch		
S	KSV 100 S	100	3,9	26,37	10
F	KSV 100 F	100	3,9	24,83	10

form-locking straight splice plate for cable ladders

2 pieces required per joint

UL classified splice plates ensure electrical continuity and proper bonding.

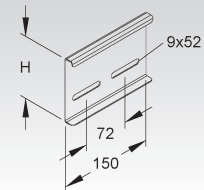

Adjustable Splice Plate

vertical

	model no.	height H		Weight per 100 pcs	Pack/Box Qty
		mm	Inch		
S	KGV 100 S	100	3,9	53,25	10
F	KGV 100 F	100	3,9	58,20	10

use for custom built horizontal elbows

2 pieces required per joint

UL classified splice plates ensure electrical continuity and proper bonding.

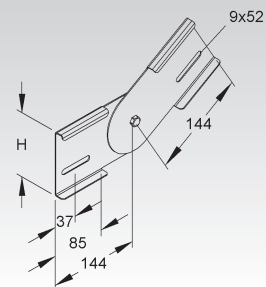

Adjustable Splice Plate

horizontal

	model no.	height H		Weight per 100 pcs kg	Pack/Box Qty
		mm	Inch		
S	KWV 100 S	100	3,9	55,0	10
F	KWV 100 F	100	3,9	59,6	10

2 pieces required per joint

UL classified splice plates ensure electrical continuity and proper bonding.

Height
100 mm
Nominal
4 inches

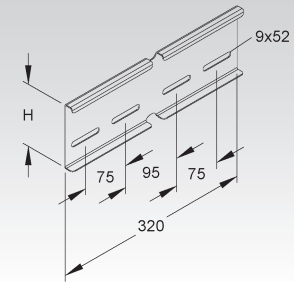

Barrier Strip

	model no.	height H		thickness t mm	Weight per 100 m kg	Pack/Box Qty
		mm	Inch			
S	RW 85	80	3,1	0,9	78,39	10 x 3 m
F	RW 85 F	80	3,1	0,9	86,12	10 x 3 m

to separate wires and cables of different voltage levels or with different functions

Height
85 mm
Nominal
3 3/8 inches



61

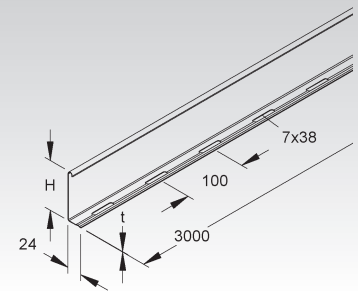

Splice Plate for Barrier Strip

	model no.	height H		length A		Weight per 100 pcs kg	Pack/Box Qty
		mm	Inch	mm	Inch		
E2	RTV 85 E2	79,5	3,1	80	3,1	2,03	20

for positive locking connections and proper bonding of barrier strips

Height
85 mm
Nominal
3 3/8 inches



61

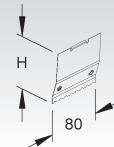

Mounting Clamp for Barrier Strip

	model no.	Weight per 100 pcs kg	Pack/Box Qty
F	KLWC 11 F	3	50

to fix barrier strips to KL... cable ladders (slot width 11 mm)

Suitable for: RW... barrier strip



61

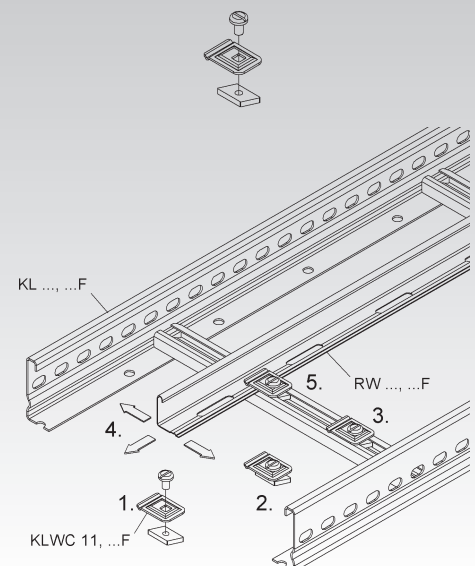

CABLE LADDER SYSTEM

Horizontal Elbow 90° (small radius)

with perforated siderails

	model no.	height H		width B		Weight per 100 pcs kg	Pack/Box Qty
		mm	Inch	mm	Inch		
S	KLBK 100.203	100	3,9	200	7,9	466,77	1
S	KLBK 100.303	100	3,9	300	11,8	533,05	1
S	KLBK 100.403	100	3,9	400	15,7	599,35	1
S	KLBK 100.503	100	3,9	500	19,7	665,67	1
S	KLBK 100.603	100	3,9	600	23,6	731,99	1
F	KLBK 100.203 F	100	3,9	200	7,9	513,45	1
F	KLBK 100.303 F	100	3,9	300	11,8	586,36	1
F	KLBK 100.403 F	100	3,9	400	15,7	659,29	1
F	KLBK 100.503 F	100	3,9	500	19,7	732,24	1
F	KLBK 100.603 F	100	3,9	600	23,6	805,19	1

Please use a KLBK... and a KLBG... elbow to form a 90° bend for 2 runs of ladder tray of the same width being installed in parallel.

KSV 100... splice plates have to be ordered separately.

Height 100 mm
Nominal 4 inches

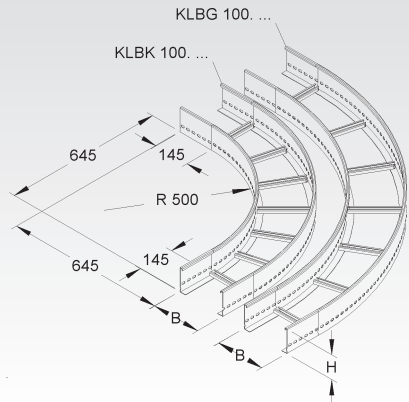
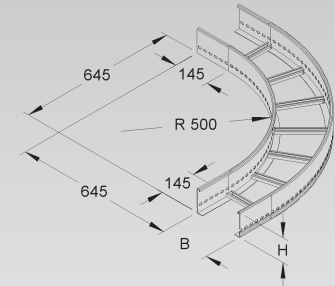

Horizontal Elbow 90° (large radius)

with perforated siderails

	model no.	height H		width B		Weight per 100 pcs kg	Pack/Box Qty
		mm	Inch	mm	Inch		
S	KLBG 100.203	100	3,9	200	7,9	615,91	1
S	KLBG 100.303	100	3,9	300	11,8	731,86	1
S	KLBG 100.403	100	3,9	400	15,7	847,88	1
S	KLBG 100.503	100	3,9	500	19,7	964,05	1
S	KLBG 100.603	100	3,9	600	23,6	1.080,14	1
F	KLBG 100.203 F	100	3,9	200	7,9	677,49	1
F	KLBG 100.303 F	100	3,9	300	11,8	805,02	1
F	KLBG 100.403 F	100	3,9	400	15,7	932,65	1
F	KLBG 100.503 F	100	3,9	500	19,7	1.060,44	1
F	KLBG 100.603 F	100	3,9	600	23,6	1.188,13	1

Please use a KLBK... and a KLBG... elbow to form a 90° bend for 2 runs of ladder tray of the same width being installed in parallel.

KSV 100... splice plates have to be ordered separately.

Height 100 mm
Nominal 4 inches

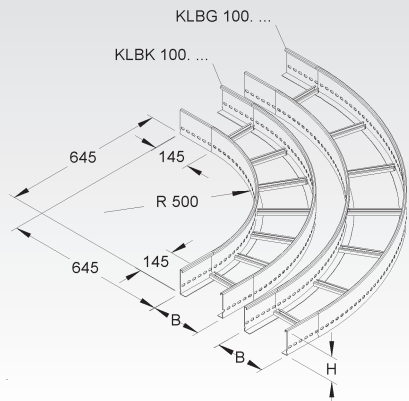
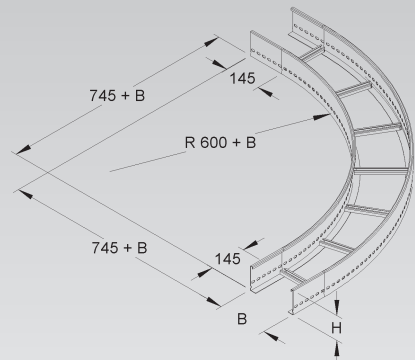

Extension Horizontal Tee

with perforated siderails

	model no.	height H		width B		Weight per 100 pcs kg	Pack/Box Qty
		mm	Inch	mm	Inch		
S	KLTA 100.203	100	3,9	200	7,9	550,75	1
S	KLTA 100.303	100	3,9	300	11,8	576,52	1
S	KLTA 100.403	100	3,9	400	15,7	601,20	1
S	KLTA 100.503	100	3,9	500	19,7	625,77	1
S	KLTA 100.603	100	3,9	600	23,6	650,34	1
F	KLTA 100.203 F	100	3,9	200	7,9	605,83	1
F	KLTA 100.303 F	100	3,9	300	11,8	634,17	1
F	KLTA 100.403 F	100	3,9	400	15,7	661,32	1
F	KLTA 100.503 F	100	3,9	500	19,7	688,35	1
F	KLTA 100.603 F	100	3,9	600	23,6	715,37	1

KSV 100... splice plates have to be ordered separately.

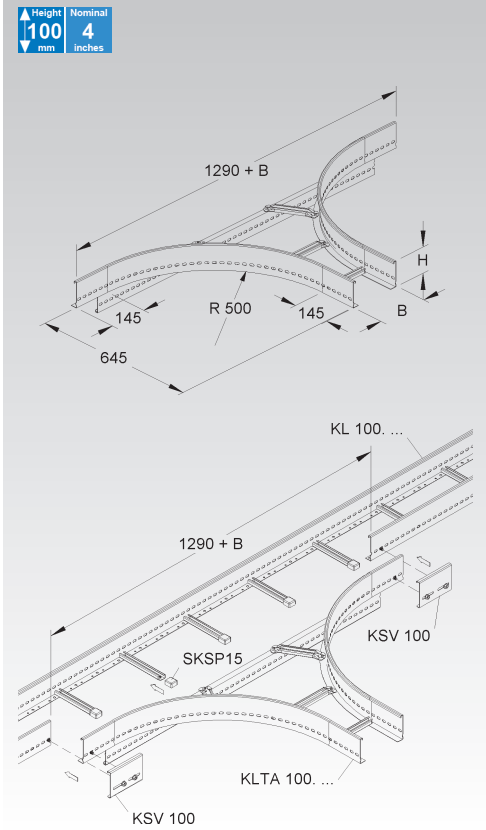

Horizontal Tee

with perforated siderails

	model no.	height H		width B		Weight per 100 pcs kg	Pack/Box Qty
		mm	Inch	mm	Inch		
S	KLT 100.203	100	3,9	200	7,9	868,22	1
S	KLT 100.303	100	3,9	300	11,8	951,82	1
S	KLT 100.403	100	3,9	400	15,7	1.034,33	1
S	KLT 100.503	100	3,9	500	19,7	1.116,73	1
S	KLT 100.603	100	3,9	600	23,6	1.244,27	1
F	KLT 100.203 F	100	3,9	200	7,9	955,04	1
F	KLT 100.303 F	100	3,9	300	11,8	1.047,00	1
F	KLT 100.403 F	100	3,9	400	15,7	1.137,76	1
F	KLT 100.503 F	100	3,9	500	19,7	1.228,40	1
F	KLT 100.603 F	100	3,9	600	23,6	1.368,70	1

KSV 100... splice plates have to be ordered separately.

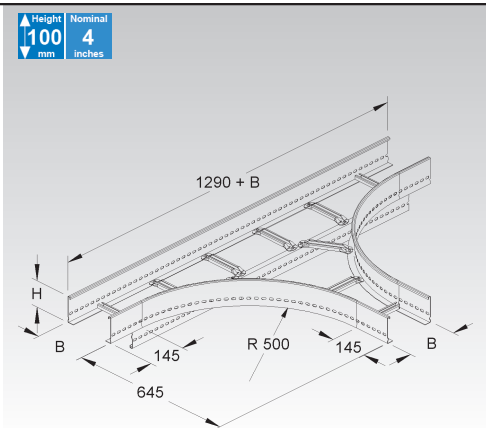

Horizontal Cross

with perforated siderails

	model no.	height H		width B		Weight per 100 pcs kg	Pack/Box Qty
		mm	Inch	mm	Inch		
S	KLK 100.203	100	3,9	200	7,9	1.183,26	1
S	KLK 100.303	100	3,9	300	11,8	1.276,81	1
S	KLK 100.403	100	3,9	400	15,7	1.368,17	1
S	KLK 100.503	100	3,9	500	19,7	1.459,33	1
S	KLK 100.603	100	3,9	600	23,6	1.595,62	1
F	KLK 100.203 F	100	3,9	200	7,9	1.301,59	1
F	KLK 100.303 F	100	3,9	300	11,8	1.404,49	1
F	KLK 100.403 F	100	3,9	400	15,7	1.504,99	1
F	KLK 100.503 F	100	3,9	500	19,7	1.605,26	1
F	KLK 100.603 F	100	3,9	600	23,6	1.755,18	1

KSV 100... splice plates have to be ordered separately.

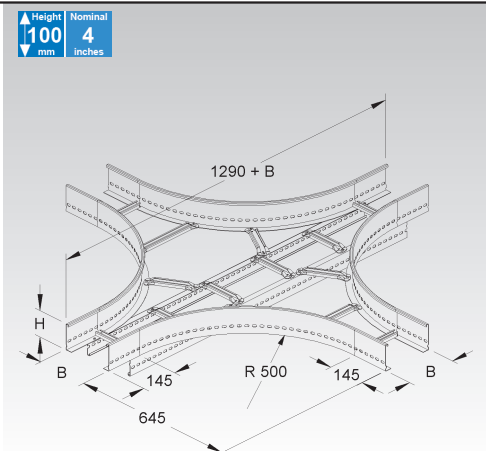

CABLE LADDER SYSTEM.....

Adjustable Vertical Elbow

vertical

	model no.	height H		width B		Weight per 100 pcs kg	Pack/Box Qty
		mm	Inch	mm	Inch		
S	KGS 100.203	100	3,9	200	7,9	660,83	1
S	KGS 100.303	100	3,9	300	11,8	684,50	1
S	KGS 100.403	100	3,9	400	15,7	708,18	1
S	KGS 100.503	100	3,9	500	19,7	731,85	1
S	KGS 100.603	100	3,9	600	23,6	755,53	1
F	KGS 100.203 F	100	3,9	200	7,9	726,08	1
F	KGS 100.303 F	100	3,9	300	11,8	752,13	1
F	KGS 100.403 F	100	3,9	400	15,7	778,14	1
F	KGS 100.503 F	100	3,9	500	19,7	804,18	1
F	KGS 100.603 F	100	3,9	600	23,6	830,23	1

delivered as a kit (not assembled)

Height 100 mm
Nominal 4 inches

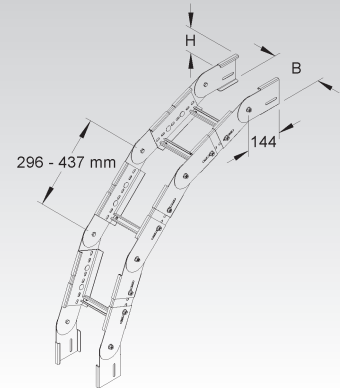

Cable Ladder Connection Bracket

	model no.	height H	Weight per 100 pcs kg	Pack/Box Qty	
		mm	Inch		
F	KLAS 100	100	3,9	20,5	20

cable ladder connector bracket for field made horizontal tees

Height 100 mm
Nominal 4 inches

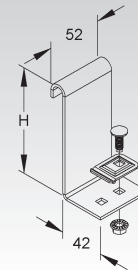

Pair of Protective End Caps

	model no.	height H	color	Weight per 100 pair kg	Pack/Box Qty	
		mm	Inch			
K10	SKK 100	100	3,9	yellow	5	10 sets

protective end cap for KL 100... siderails

Suitable for: Cable Ladder

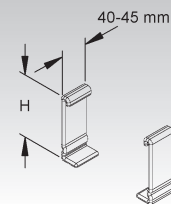

Ladder Drop Out

with rounded edges

	model no.	width B	Weight per 100 pcs kg	Pack/Box Qty	
		mm	Inch		
S	KLAB 200	190	7,5	40,85	1
S	KLAB 300	290	11,4	63,60	1
S	KLAB 400	390	15,4	86,35	1
S	KLAB 500	490	19,3	143,37	1
S	KLAB 600	590	23,2	173,42	1
F	KLAB 200 F	190	7,5	45,96	1
F	KLAB 300 F	290	11,4	70,98	1
F	KLAB 400 F	390	15,4	96,01	1
F	KLAB 500 F	490	19,3	158,73	1
F	KLAB 600 F	590	23,2	191,78	1
E3	KLAB 200 E3	190	7,5	41,03	1
E3	KLAB 300 E3	290	11,4	63,93	1
E3	KLAB 400 E3	390	15,4	86,83	1
E3	KLAB 500 E3	490	19,3	144,21	1
E3	KLAB 600 E3	590	23,2	174,45	1

Suitable for: KL... cable ladders

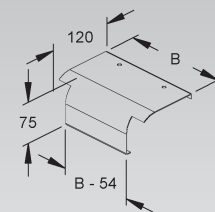

Cable Ladder Mounting Bracket

model no.	Weight per 100 pcs kg	Pack/Box Qty
S KLTB 6	2,13	50
F KLTB 6 F	2,22	50
E3 KLTB 6 E3	2,37	50
E5 KLTB 6 E5	2,40	50

hold down clamp to fix cable ladders on brackets

2 pieces required per bracket



Two Hole Corner Angle

model no.	thickness mm	Weight per 100 pcs kg	Pack/Box Qty
F WWU 150/8	5	19,11	50
E3 WWU 150/8 E3	4	14,87	50
E5 WWU 150/8 E5	4	14,62	50

for floor-, ceiling- or wall-mount

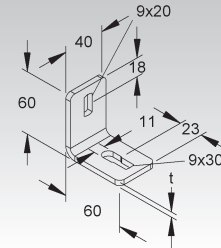

Three Hole Corner Angle

model no.	thickness mm	Weight per 100 pcs kg	Pack/Box Qty
F WWA 100	5	24,98	50
E3 WWA 100 E3	4	19,75	50

for floor-, ceiling- or wall-mount

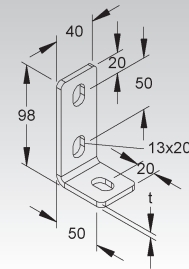

CABLE LADDER SYSTEM ACCESSOIRES

Cover for Cable Tray/Ladder

with turnbolt locks

	model no.	inside dimension (B)		Weight per 100 m	Pack/Box Qty
		mm	Inch		
S	RDV 200	200	7,9	133,2	2 x 3 m
S	RDV 300	300	11,8	230,2	2 x 3 m
S	RDV 400	400	15,7	334,1	2 x 3 m
S	RDV 500	500	19,7	412,6	2 x 3 m
S	RDV 600	600	23,6	491,1	2 x 3 m
F	RDV 200 F	200	7,9	146,6	2 x 3 m
F	RDV 300 F	300	11,8	253,2	2 x 3 m
F	RDV 400 F	400	15,7	367,5	2 x 3 m
F	RDV 500 F	500	19,7	453,8	2 x 3 m
F	RDV 600 F	600	23,6	540,2	2 x 3 m

For outdoor service covers need to be secured against windloads using heavy duty cover clamps or steel cable ties.

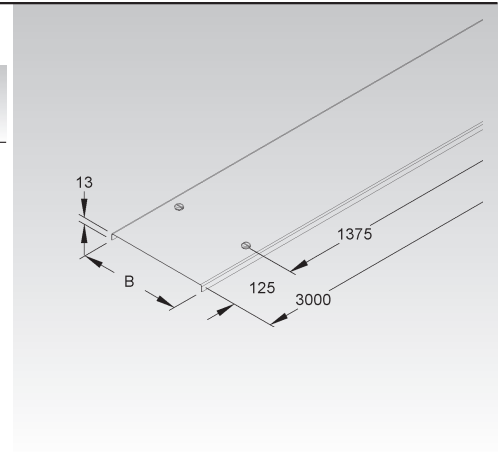

Cover for 90° Horizontal Elbow (small radius)

with turnbolt locks

	model no.	inside dimension (B)		Weight per 100 pcs	Pack/Box Qty
		mm	Inch		
S	KLBKDV 200	203	8	202,76	1
S	KLBKDV 300	303	11,9	317,53	1
S	KLBKDV 400	403	15,9	444,62	1
S	KLBKDV 500	503	19,8	584,04	1
S	KLBKDV 600	603	23,7	735,79	1
F	KLBKDV 200 F	203	8	223,04	1
F	KLBKDV 300 F	303	11,9	349,28	1
F	KLBKDV 400 F	403	15,9	489,08	1
F	KLBKDV 500 F	503	19,8	642,44	1
F	KLBKDV 600 F	603	23,7	809,37	1

For outdoor service covers need to be secured against windloads using heavy duty cover clamps or steel cable ties.

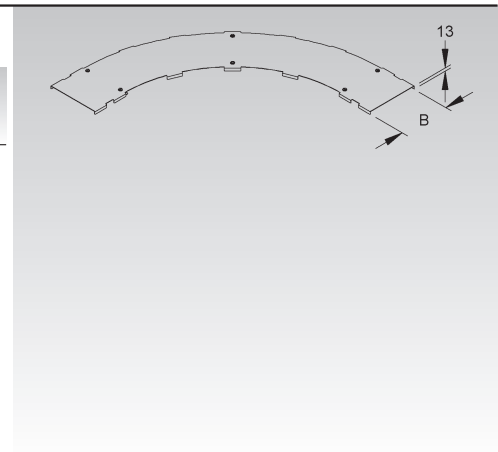

Cover for Horizontal Tee

with turnbolt locks

	model no.	inside dimension (B)		Weight per 100 pcs	Pack/Box Qty
		mm	Inch		
S	KLTDV 200	203	8	444,10	1
S	KLTDV 300	303	11,9	636,22	1
S	KLTDV 400	403	15,9	844,03	1
S	KLTDV 500	503	19,8	1.067,55	1
S	KLTDV 600	603	23,7	1.306,77	1
F	KLTDV 200 F	203	8	488,51	1
F	KLTDV 300 F	303	11,9	699,84	1
F	KLTDV 400 F	403	15,9	928,44	1
F	KLTDV 500 F	503	19,8	1.174,31	1
F	KLTDV 600 F	603	23,7	1.437,45	1

For outdoor service covers need to be secured against windloads using heavy duty cover clamps or steel cable ties.

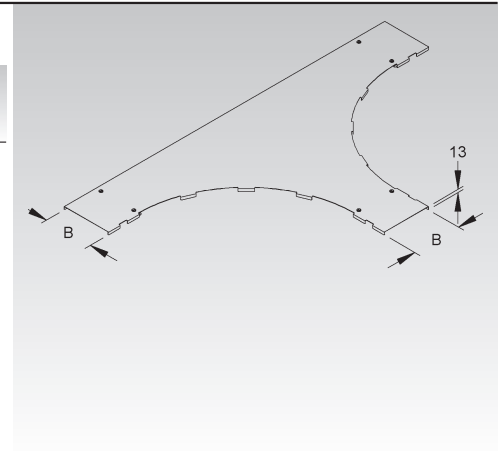

Turnbolt Lock

locking nut included

	model no.	Weight per 100 pcs kg	Pack/ Box Qty
S	RDRS 9	1,2	100
F	RDRS 9 F	1,6	100

for field modifications of covers

Suitable for: RD... and RDV... covers
fitting covers

Not sufficient for securing covers to tray installed vertically or sideways nor for securing covers against windloads. Please use self tapping screws, steel cable ties or cover-hinges in addition.

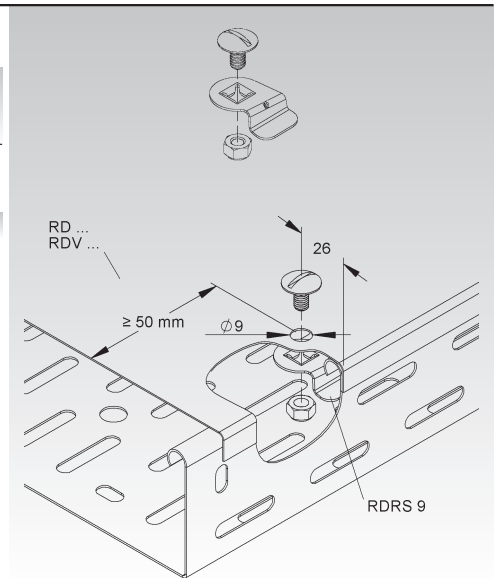



VERTICAL CABLE LADDER SYSTEM

- Vertical Cable Ladder
- Splice Plates
- Accessoires



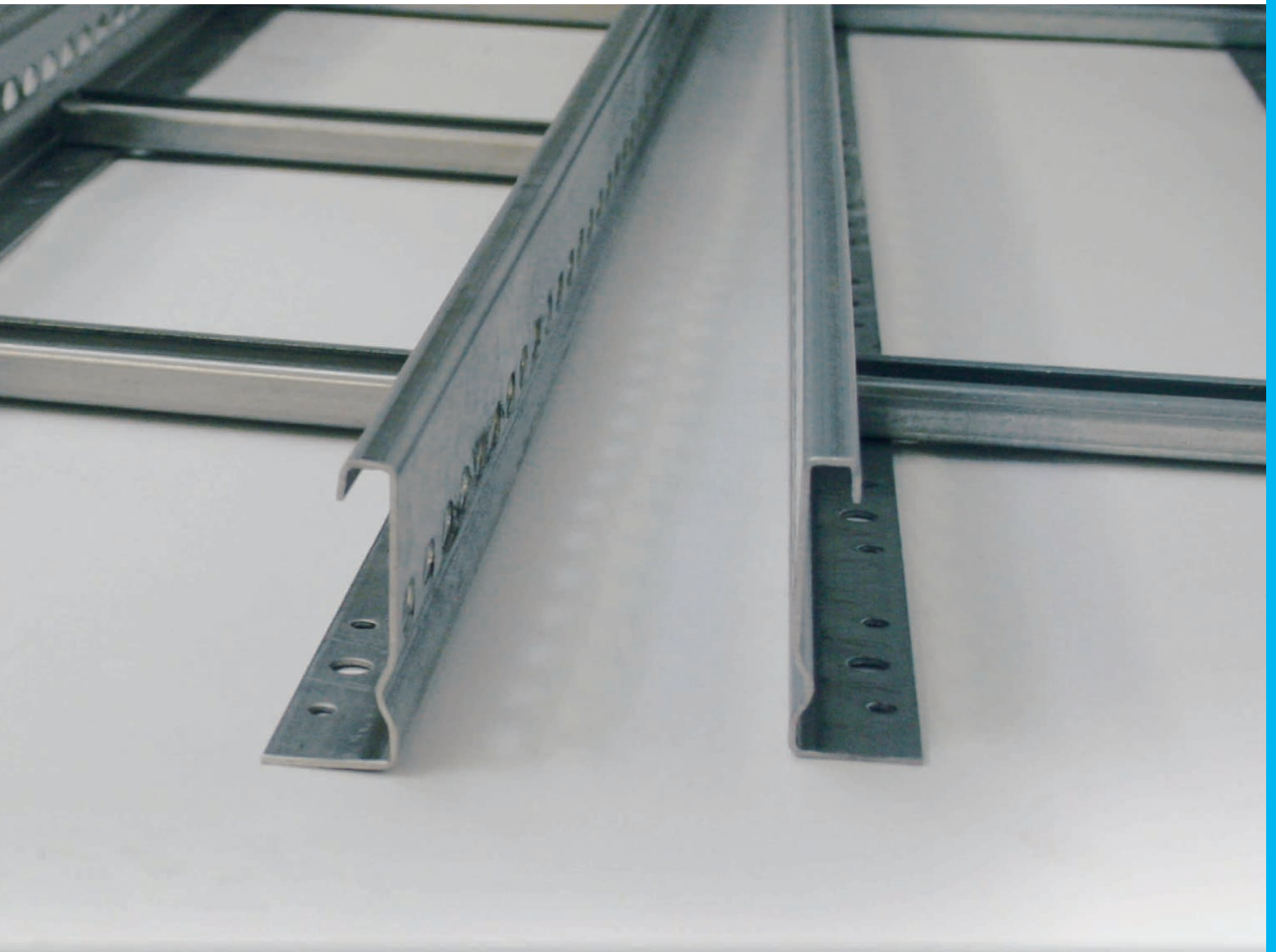

Niedax vertical cable ladders are available in a wide range of sizes and finishes. They are designed to mount cables directly to the horizontal rungs using various kinds and sizes of Niedax yoke clamps. Light and medium duty versions can be bolted directly to the wall, the heavy duty version based on the I 80 profile is mounted using a wall support bracket.

VERTICAL CABLE LADDER SYSTEM

Available Side Rail Heights



SYSTEM	Vertical Cable Ladder	STUC...	Page 258
	Vertical Cable Ladder	STIC...	Page 260
ZUBEHÖR	Rungs for Vertical Cable Ladders	SPCKL...	Page 258
	Straight Splice Plate	VB 6040	Page 258
	Two Hole Corner Angle	WWU 150	Page 259
	Profile U 6040	U 6040...	Page 259
	Rungs for Vertical Cable Ladders	SPC 86/...	Page 260
	Two Hole Corner Angle for I 80	WWI 80	Page 261
	Straight Splice Plate	VBI 80	Page 261
	Head Plate	KI 80	Page 261
	Head Plate	KIQ 80	Page 261
	Profile I 80	I 80/...	Page 262
	Enclosure Panel Kit for Vertical Ladder	STVWA...	Page 262
	Enclosure Panel Kit for Vertical Ladder	STVFA...	Page 263
	Mounting Kit for Enclosure Panel	STVDP 30.43...	Page 263
	Heavy Duty Cover Clamp	RDHFS 9...	Page 263



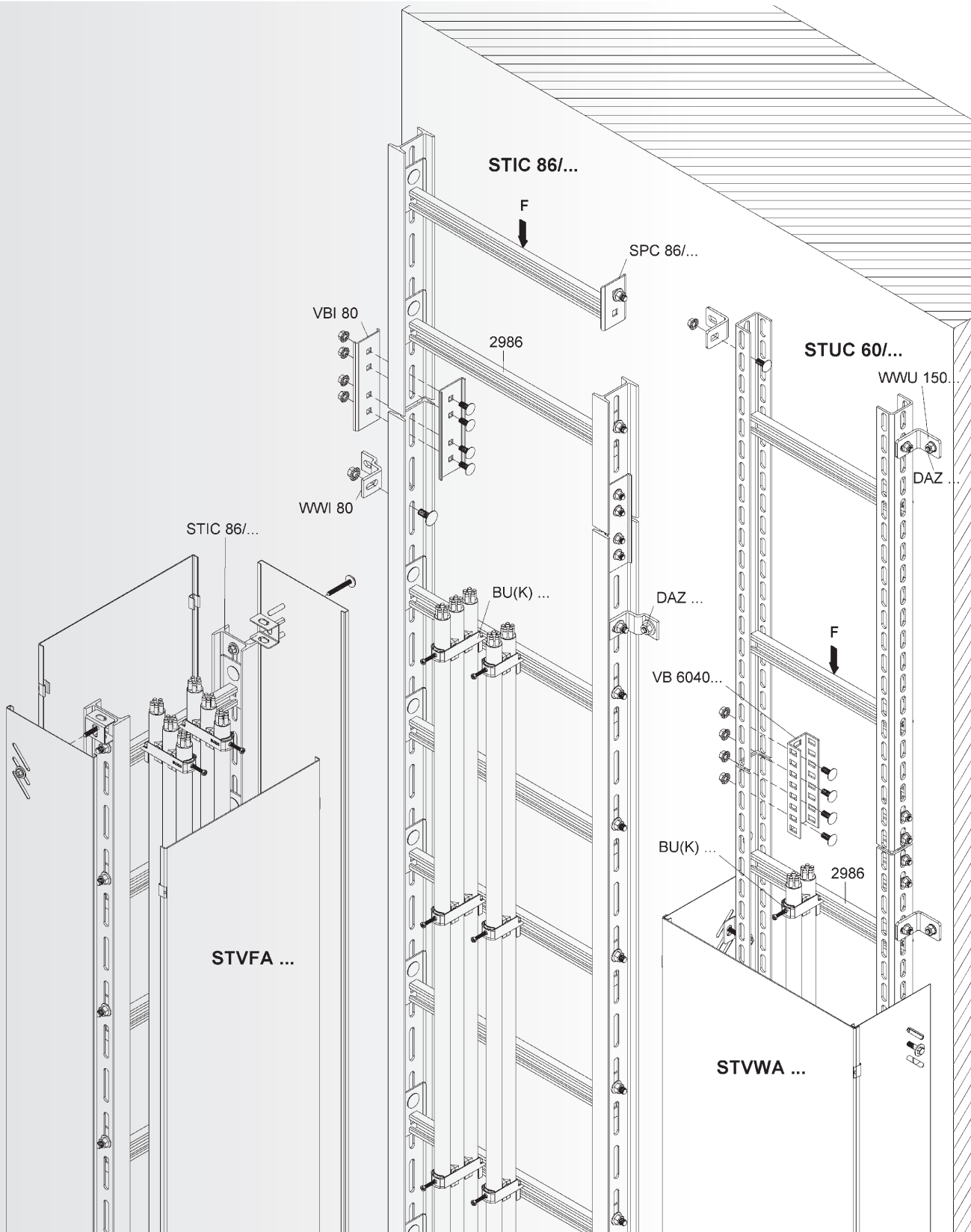

VERTICAL CABLE LADDER SYSTEM

Vertical Cable Ladder

delivered as a kit (not assembled)

	model no.	height H		width B		length A		admissible load F	Weight per 100 m kg	Pack/Box Qty
		mm	Inch	mm	Inch	mm	Inch			
F	STUC 60/205 F	60	2,4	215	8,5	4500	177,2	1,75	755,1	4,5 m
F	STUC 60/305 F	60	2,4	315	12,4	4500	177,2	1,75	788,0	4,5 m
F	STUC 60/405 F	60	2,4	415	16,3	4500	177,2	1,75	820,8	4,5 m
F	STUC 60/505 F	60	2,4	515	20,3	4500	177,2	1,75	853,7	4,5 m
F	STUC 60/605 F	60	2,4	615	24,2	4500	177,2	1,75	886,6	4,5 m
F	STUC 60/705 F	60	2,4	715	28,1	4500	177,2	1	919,5	4,5 m
F	STUC 60/805 F	60	2,4	815	32,1	4500	177,2	1	952,4	4,5 m
F	STUC 60/905 F	60	2,4	915	36	4500	177,2	1	985,3	4,5 m
F	STUC 60/1005 F	60	2,4	1015	40	4500	177,2	1	1.018,1	4,5 m
F	STUC 60/1105 F	60	2,4	1115	43,9	4500	177,2	1	1.051,0	4,5 m
F	STUC 60/1205 F	60	2,4	1215	47,8	4500	177,2	1	1.083,9	4,5 m

50 mm center distance for punch holes 13x40 mm on all 3 sides of the rail

delivered as a kit (not assembled)

Corresponding yoke clamps (BU... and BUK...) are listed in a separate section of this catalog.

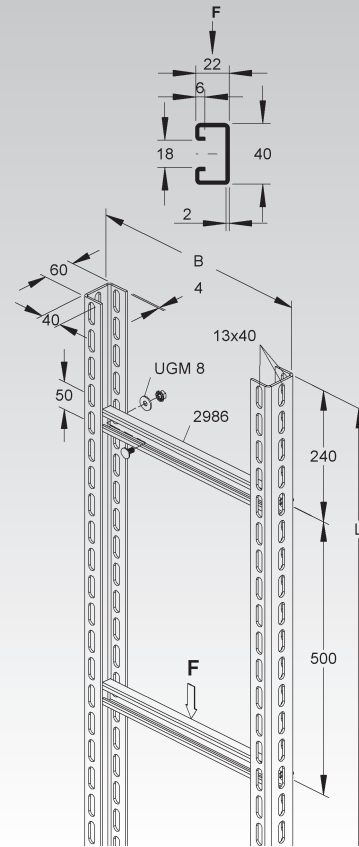

Rungs for Vertical Cable Ladders

C-rail type 2986 (40x22x2), for additional needs

	model no.	width B		admissible load F	Weight per 100 pc. kg	Pack/Box Qty
		mm	Inch			
F	SPCKL 86/200 F	200	7,9	1,75	38,76	1
F	SPCKL 86/300 F	300	11,8	1,75	55,20	1
F	SPCKL 86/400 F	400	15,7	1,75	71,65	1
F	SPCKL 86/500 F	500	19,7	1,75	88,09	1
F	SPCKL 86/600 F	600	23,6	1,75	104,53	1
F	SPCKL 86/700 F	700	27,6	1	120,97	1
F	SPCKL 86/800 F	800	31,5	1	137,42	1
F	SPCKL 86/900 F	900	35,4	1	153,85	1
F	SPCKL 86/1000 F	1000	39,4	1	170,30	1
F	SPCKL 86/1100 F	1100	43,3	1	186,74	1
F	SPCKL 86/1200 F	1200	47,2	1	203,19	1

Suitable for: vertical cable ladder STUC 60/...F

Corresponding yoke clamps (BU... and BUK...) are listed in a separate section of this catalog.

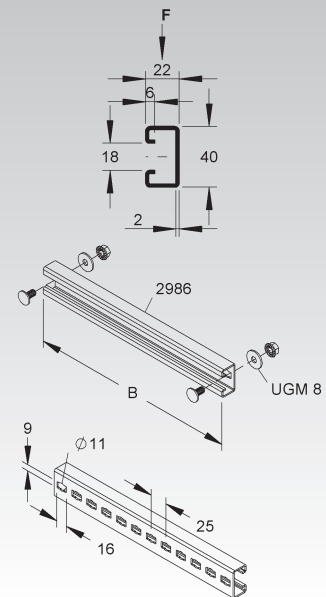

Straight Splice Plate

	model no.	Weight per 100 pcs kg	Pack/Box Qty
F	VB 6040	61,2	10

Suitable for: profile U 6040/...

Slotted hole size 11x18 mm, 50 mm pitch.

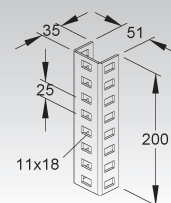

Two Hole Corner Angle

model no.	Weight per 100 pcs kg	Pack/Box Qty
F WWU 150	21,03	50

for floor-, ceiling- or wall-mount

Suitable for: U-profile U 50/..., U 5050/... and U 6040/...

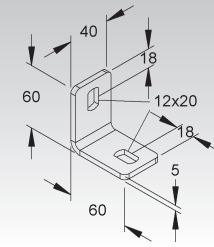

Profile U 6040

	model no.	length A		Weight per 100 m kg	Pack/Box Qty
		mm	Inch		
F	U 6040/3000 F	3000	118,1	338,68	3 m
F	U 6040/6000 F	6000	236,2	338,68	6 m

for building customized overhead hangers, floorstands or support frames

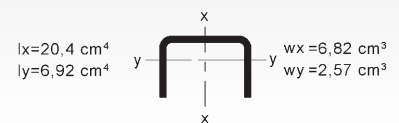
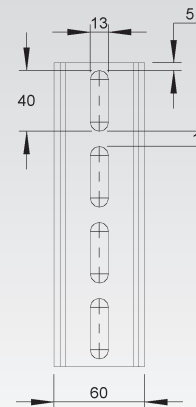
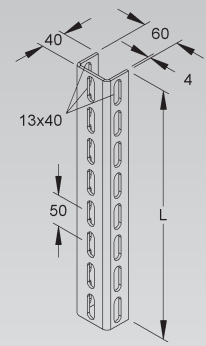

VERTICAL CABLE LADDER SYSTEM

Vertical Cable Ladder

heavy-duty version, delivered as a kit (not assembled)

	model no.	height H		width B		rung spacing A		admissible load F	Weight per 100 m	Pack/Box Qty
		mm	Inch	mm	Inch	mm	Inch			
F	STIC 86/206	80	3,1	280	11	600	23,6	1,75	1.388,52	6 m
F	STIC 86/306	80	3,1	380	15	600	23,6	1,75	1.417,67	6 m
F	STIC 86/406	80	3,1	480	18,9	600	23,6	1,75	1.446,82	6 m
F	STIC 86/506	80	3,1	580	22,8	600	23,6	1,75	1.475,97	6 m
F	STIC 86/606	80	3,1	680	26,8	600	23,6	1,75	1.505,12	6 m
F	STIC 86/706	80	3,1	780	30,7	600	23,6	1	1.534,27	6 m
F	STIC 86/806	80	3,1	880	34,6	600	23,6	1	1.563,42	6 m
F	STIC 86/906	80	3,1	980	38,6	600	23,6	1	1.592,58	6 m
F	STIC 86/1006	80	3,1	1080	42,5	600	23,6	1	1.621,73	6 m
F	STIC 86/1106	80	3,1	1180	46,5	600	23,6	1	1.650,88	6 m
F	STIC 86/1206	80	3,1	1280	50,4	600	23,6	1	1.680,03	6 m

side rails are made of I80 profiles (DIN 1025 compliant), rungs are made of C-profile type 2986

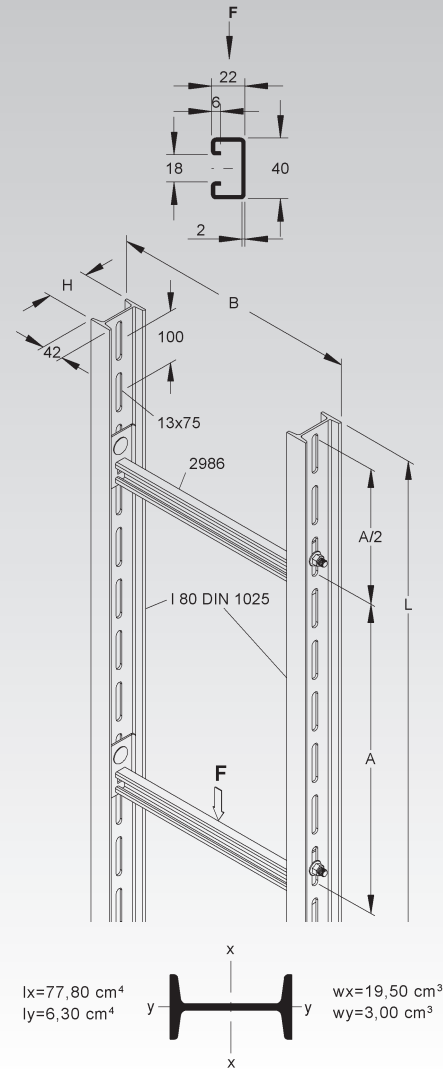

Rungs for Vertical Cable Ladders

C-rail type 2986 (40x22x2), for additional needs

	model no.	width B		admissible load F	Weight per 100	Pack/Box Qty
		mm	Inch			
F	SPC 86/200	234	9,2	1,75	87,7	1
F	SPC 86/300	334	13,1	1,75	105,2	1
F	SPC 86/400	434	17,1	1,75	122,7	1
F	SPC 86/500	534	21	1,75	140,2	1
F	SPC 86/600	634	25	1,75	157,7	1
F	SPC 86/700	734	28,9	1	175,1	1
F	SPC 86/800	834	32,8	1	192,6	1
F	SPC 86/900	934	36,8	1	210,1	1
F	SPC 86/1000	1034	40,7	1	227,6	1
F	SPC 86/1100	1134	44,6	1	245,1	1
F	SPC 86/1200	1234	48,6	1	262,6	1

Suitable for: vertical cable ladder STIC 86/...

Corresponding yoke clamps (BU... and BUK...) are listed in a separate section of this catalog.

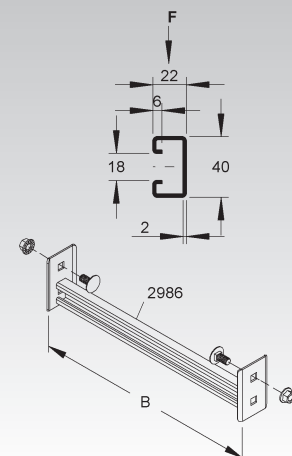

Two Hole Corner Angle for I 80

equal-sided

model no.	Weight per 100 pc. kg	Pack/Box Qty
F WWI 80	28,67	50

for wall-mounting of I 80/... profiles

Suitable for: profile I 80/..., overhead hangers HI 80/... and vertical cable ladders of type STIC.... and STIW...

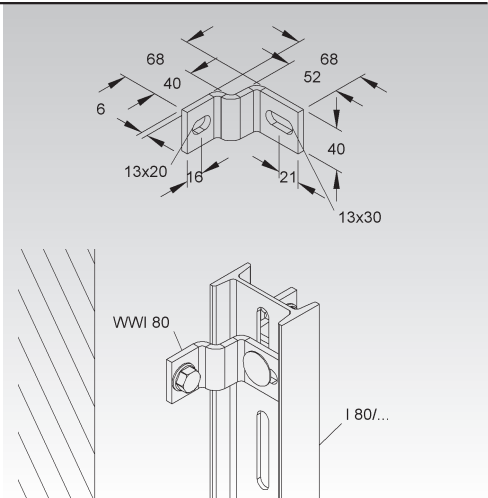

Straight Splice Plate

model no.	Weight per 100 pair kg	Pack/Box Qty
F VBI 80	76	5 sets

2 pieces required per joint

Suitable for: profile I 80/... and overhead hanger HI 80/...

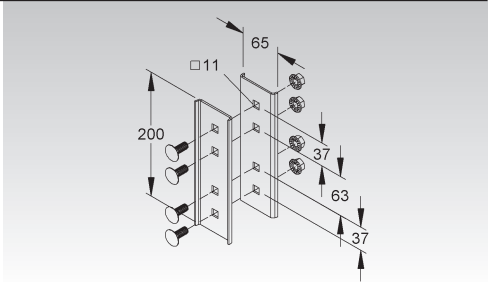

Head Plate

model no.	Total length L	thickness of the head plate t	Weight per 100 pcs kg	Pack/Box Qty
	mm Inch	mm Inch		
F KI 80	151 5,9	6 0,2	135,9	1

for mounting on horizontal ceilings

Suitable for: profile I 80/...

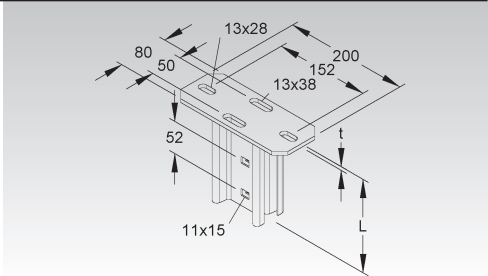

Head Plate

crosswise to profile I 80

model no.	Total length L	thickness of the head plate t	Weight per 100 pc. kg	Pack/Box Qty
	mm Inch	mm Inch		
F KIQ 80	151 5,9	6 0,2	151,76	1

for mounting on horizontal ceilings

Suitable for: profile I 80/...

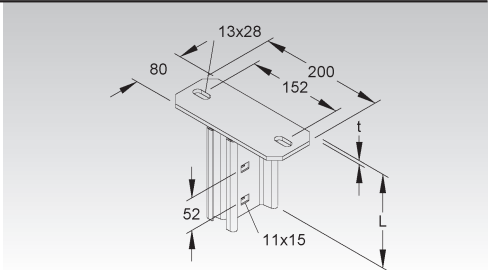

VERTICAL CABLE LADDER SYSTEM

Profile I 80

according to DIN 1025 standard

	model no.	length A		Weight per 100 m kg	Pack/Box Qty
		mm	Inch		
F	I 80/3000 FL	3000	118,1	622,3	3 m
F	I 80/6000 FL	6000	236,2	622,3	6 m

for building customized overhead hangers, floorstands or support frames

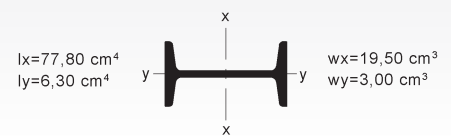
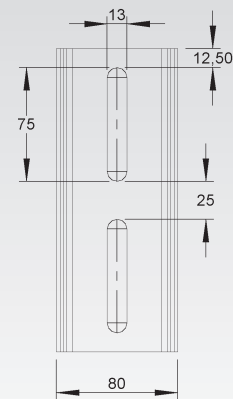
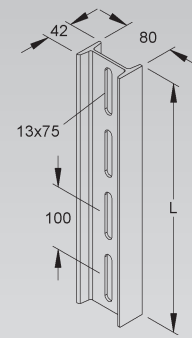

Enclosure Panel Kit for Vertical Ladder

	model no.	height H		width B		length A		Weight per 100 kg	Pack/Box Qty
		mm	Inch	mm	Inch	mm	Inch		
S	STVWA 200 S	203	8	309	12,2	3000	118,1	873,79	3 m
S	STVWA 300 S	203	8	409	16,1	3000	118,1	1.030,79	3 m
S	STVWA 400 S	203	8	509	20	3000	118,1	1.187,79	3 m
S	STVWA 500 S	203	8	609	24	3000	118,1	1.344,79	3 m
S	STVWA 600 S	203	8	709	27,9	3000	118,1	1.501,79	3 m
F	STVWA 200 F	203	8	309	12,2	3000	118,1	964,48	3 m
F	STVWA 300 F	203	8	409	16,1	3000	118,1	1.137,18	3 m
F	STVWA 400 F	203	8	509	20	3000	118,1	1.309,88	3 m
F	STVWA 500 F	203	8	609	24	3000	118,1	1.482,58	3 m
F	STVWA 600 F	203	8	709	27,9	3000	118,1	1.655,28	3 m

Suitable for: STUC 60/... and STIC 86/... only

Kit contains 2 sidepanels, 6 brackets, 1 cover and 6 clamps.

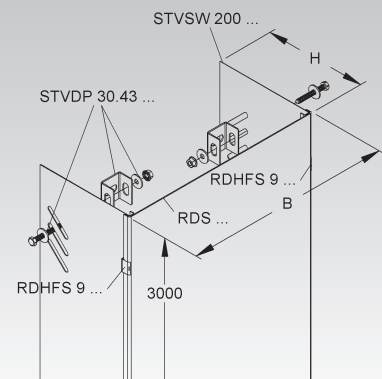

Enclosure Panel Kit for Vertical Ladder

	model no.	height H		width B		length A		Weight per 100 kg	Pack/Box Qty
		mm	Inch	mm	Inch	mm	Inch		
S	STVFA 200 S	236	9,3	309	12,2	3000	118,1	1.464,59	3 m
S	STVFA 300 S	236	9,3	409	16,1	3000	118,1	1.778,59	3 m
S	STVFA 400 S	236	9,3	509	20	3000	118,1	2.092,59	3 m
S	STVFA 500 S	236	9,3	609	24	3000	118,1	2.406,59	3 m
S	STVFA 600 S	236	9,3	709	27,9	3000	118,1	2.720,59	3 m
F	STVFA 200 F	236	9,3	309	12,2	3000	118,1	1.614,36	3 m
F	STVFA 300 F	236	9,3	409	16,1	3000	118,1	1.959,76	3 m
F	STVFA 400 F	236	9,3	509	20	3000	118,1	2.305,16	3 m
F	STVFA 500 F	236	9,3	609	24	3000	118,1	2.650,56	3 m
F	STVFA 600 F	236	9,3	709	27,9	3000	118,1	2.995,96	3 m

Suitable for: STUC 60/... and STIC 86/... only

Kit contains 2 sidepanels, 6 brackets, 2 covers and 12 clamps.

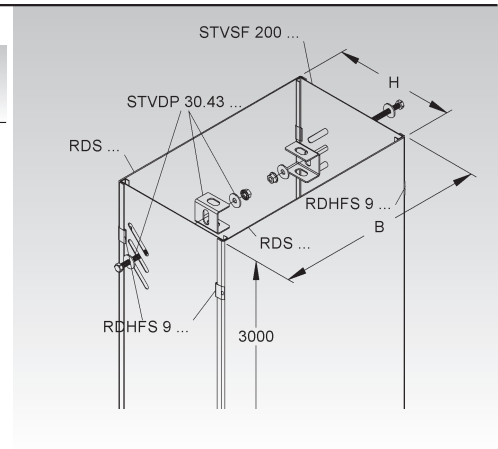

Mounting Kit for Enclosure Panel

	model no.	Weight per 100	Pack/Box Qty
		kg	
S	STVDP 30.43 S	10,70	6
F	STVDP 30.43 F	11,32	6

Suitable for: STVWA... and STVFA... only

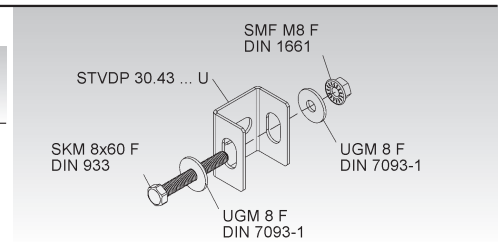

Heavy Duty Cover Clamp

	model no.	Weight per 100	Pack/Box Qty
		pcs/kg	
V	RDHFS 9 V	0,92	60
F	RDHFS 9 F	1,01	60

Suitable for: RDS..., RDSV..., RDRS... and RDVSRSL... covers

Not sufficient for securing covers to tray installed vertically or sideways nor for securing covers against windloads. Please use self tapping screws, steel cable ties or cover-hinges in addition.

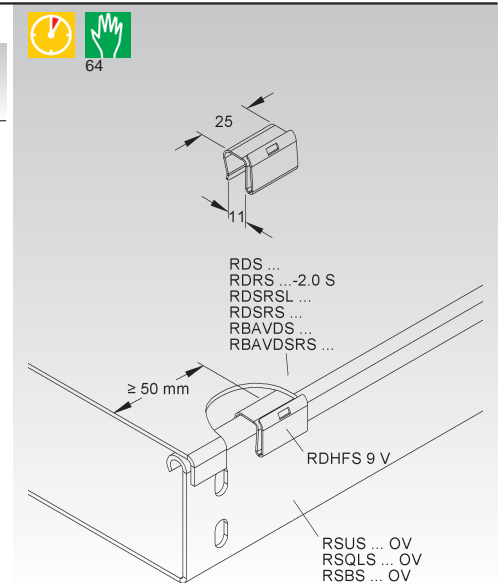



MARINE CABLE LADDER SYSTEM

- Cable Ladder
- Rungs
- Splice Plates





The Niedax Marine Cable Ladder was originally designed for shipbuilding only. Today the marine ladder is used in many different areas, for example in power plants, refineries, heavy industry and in tunnels. Heavy duty perforated siderails allow welding and/or bolting to support structures. Cables can be banded very easy to the slotted rungs using plastic or stainless steel cable ties.

MARINE CABLE LADDER SYSTEM

Available Side Rail Heights

SYSTEM	Marine Cable Ladder	KLMUL...	Page 269
ZUBEHÖR	Trapeze Rungs	SPM 3000...	Page 269
	Splice Plate	KLMV...	Page 269
	Extension Horizontal Tee	KLMUAT..	Page 270
	Horizontal Elbow 45°	KLMUBB...	Page 270
	Horizontal Elbow 90°	KLMUB...	Page 270
	Mushroom Head Bolt	FLM 8X25 F	Page 270

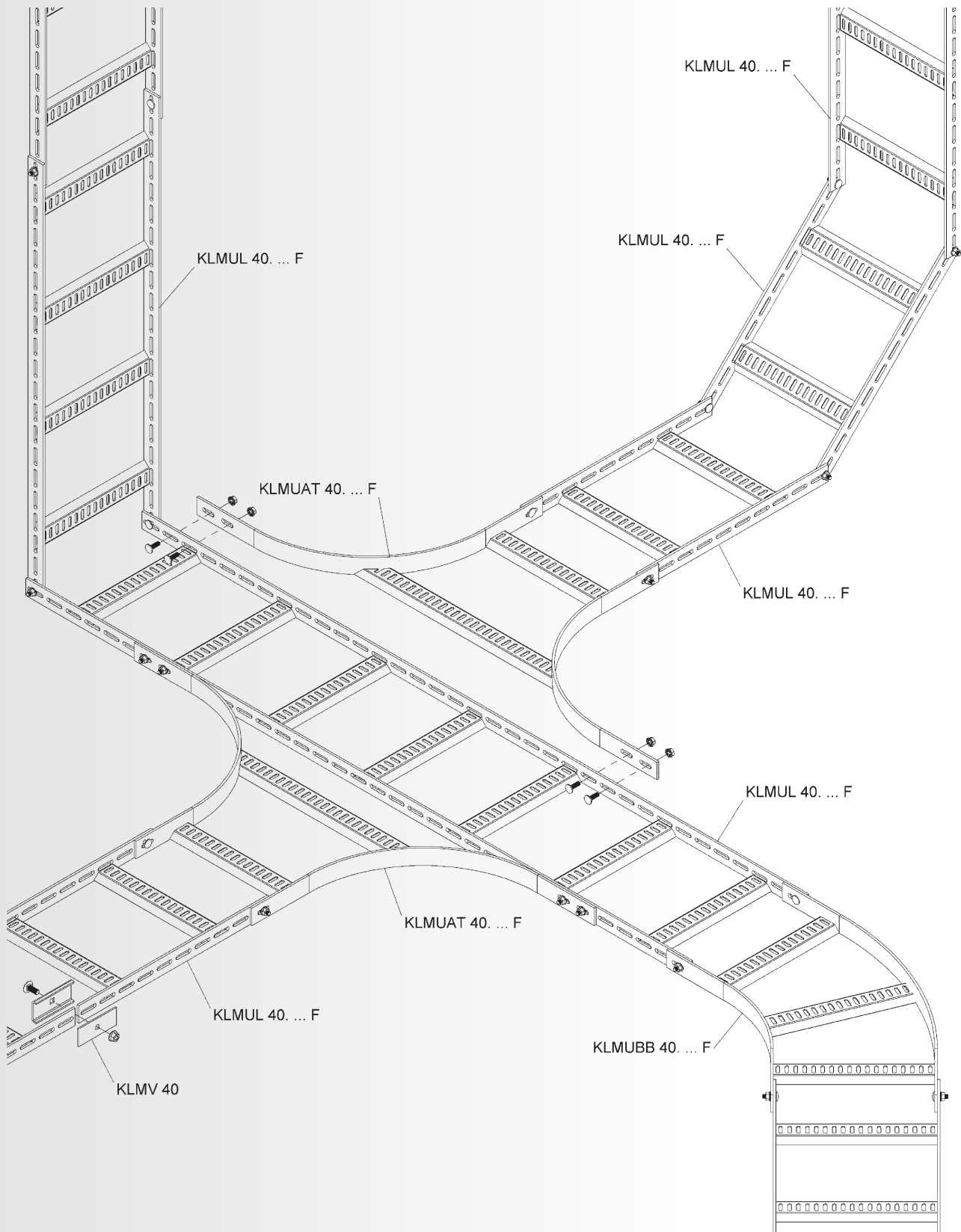

 **Load/Span Class Designation in accordance with NEMA VE 1 and CSA E22.2 No. 126.1**

NIEDAX Series	Minimum Area		Load class in accordance to NEMA VE 1		
	(calculational) mm ² / in. ²	in accordance to NEMA VE 2 mm ² / in. ²	Rated Load Kg/m / lb./ft.	Support spacing m / ft.	Load/Span Class
KLMULX 40.100 F	315 / 0.49	258 / 0.40	145 / 97.4	2 / 6.6	C
KLMULX 40.150 F	315 / 0.49	258 / 0.40	145 / 97.4	2 / 6.6	C
KLMULX 40.200 F	315 / 0.49	258 / 0.40	145 / 97.4	2 / 6.6	C
KLMULX 40.300 F	315 / 0.49	258 / 0.40	145 / 97.4	2 / 6.6	C
KLMULX 40.400 F	315 / 0.49	258 / 0.40	145 / 97.4	2 / 6.6	C
KLMULX 40.500 F	315 / 0.49	258 / 0.40	145 / 97.4	2 / 6.6	C
KLMULX 40.600 F	315 / 0.49	258 / 0.40	145 / 97.4	2 / 6.6	C
KLMULX 40.700 F	315 / 0.49	258 / 0.40	145 / 97.4	2 / 6.6	C
KLMULX 40.900 F	315 / 0.49	258 / 0.40	145 / 97.4	2 / 6.6	C
KLMULX 40.150 E5	315 / 0.49	258 / 0.40	145 / 97.4	2 / 6.6	A
KLMULX 40.300 E5	315 / 0.49	258 / 0.40	145 / 97.4	2 / 6.6	A
KLMULX 40.600 E5	315 / 0.49	258 / 0.40	145 / 97.4	2 / 6.6	A



Marine Cable Ladder

with perforated siderail

	model no.	height H		width B		thick-ness t	Weight per 100 m/kg	Pack/Box Qty
		mm	Inch	mm	Inch			
F	KLMUL 40.100 F	40	1,6	110	4,3	5	331,76	3 m
F	KLMUL 40.150 F	40	1,6	160	6,3	5	352,96	3 m
F	KLMUL 40.200 F	40	1,6	210	8,3	5	374,15	3 m
F	KLMUL 40.300 F	40	1,6	310	12,2	5	416,56	3 m
F	KLMUL 40.400 F	40	1,6	410	16,1	5	458,95	3 m
F	KLMUL 40.500 F	40	1,6	510	20,1	5	501,35	3 m
F	KLMUL 40.600 F	40	1,6	610	24	5	543,75	3 m
F	KLMUL 40.700 F	40	1,6	710	28	5	586,15	3 m
F	KLMUL 40.900 F	40	1,6	910	35,8	5	670,94	3 m
E5	KLMUL 40.150 E5	40	1,6	160	6,3	5	326,18	3 m
E5	KLMUL 40.300 E5	40	1,6	310	12,2	5	384,96	3 m
E5	KLMUL 40.600 E5	40	1,6	610	24	5	502,50	3 m

Other sizes are available on request.

Load Chart: q = uniformly distributed load (tested according to DIN EN IEC 61537 standard)

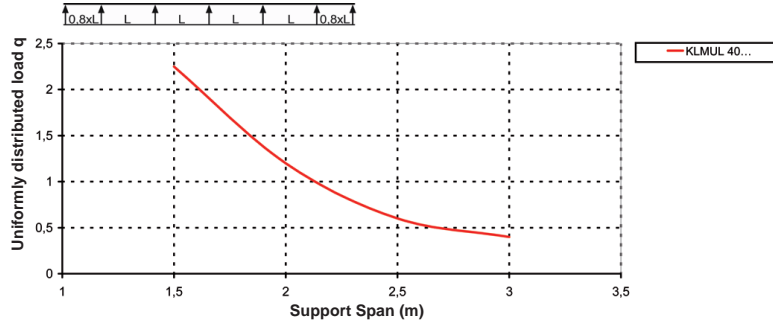

Specified load ratings are independent of splice plate location.

Height 40 mm
Nominal 1 5/8 inches

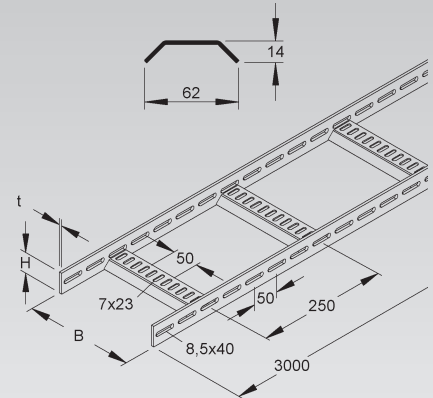

Trapeze Rungs

	model no.	width B		Weight per 100 m/kg	Pack/Box Qty
		mm	Inch		
B	SPM 3000 B	3000	118,1	96,36	3 m
AL	SPM 3000.3 AL	3000	118,1	49,79	3 m
E5	SPM 3000 E5	3000	118,1	97,95	3 m

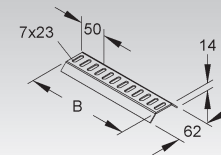

Splice Plate

	model no.	height H		Weight per 100 pcs/kg	Pack/Box Qty
		mm	Inch		
F	KLMV 40	41	1,6	29,70	20
E5	KLMV 40 E5	41	1,6	27,17	20

form-locking straight splice plate for cable ladders

2 pieces required per joint

UL classified splice plates ensure electrical continuity and proper bonding.

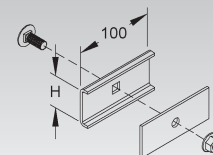

MARINE CABLE LADDER SYSTEM

Extension Horizontal Tee

with integrated splice

	model no.	height H		width B		thick-ness t	Weight per 100 pcs kg	Pack/Box Qty
		mm	Inch	mm	Inch			
F	KLMUAT 40.100 F	40	1,6	100	3,9	5	299,54	1
F	KLMUAT 40.150 F	40	1,6	150	5,9	5	310,10	1
F	KLMUAT 40.200 F	40	1,6	200	7,9	5	320,74	1
F	KLMUAT 40.300 F	40	1,6	300	11,8	5	341,94	1
F	KLMUAT 40.400 F	40	1,6	400	15,7	5	363,14	1
F	KLMUAT 40.500 F	40	1,6	500	19,7	5	384,34	1
F	KLMUAT 40.600 F	40	1,6	600	23,6	5	405,54	1
F	KLMUAT 40.700 F	40	1,6	700	27,6	5	426,73	1
F	KLMUAT 40.900 F	40	1,6	900	35,4	5	469,13	1

Extension tees can be bolted directly to straight sections of KLMUL 40... ladders.

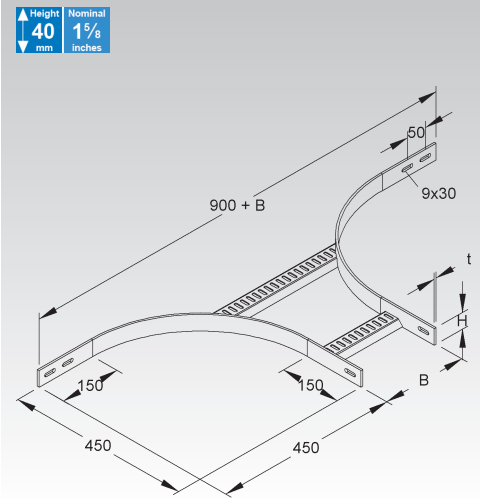

Horizontal Elbow 45°

with integrated splice

	model no.	height H		width B		thick-ness t	Weight per 100 pcs kg	Pack/Box Qty
		mm	Inch	mm	Inch			
F	KLMUBB 40.100 F	40	1,6	100	3,9	5	227,36	1
F	KLMUBB 40.150 F	40	1,6	150	5,9	5	250,04	1
F	KLMUBB 40.200 F	40	1,6	200	7,9	5	272,72	1
F	KLMUBB 40.300 F	40	1,6	300	11,8	5	318,09	1
F	KLMUBB 40.400 F	40	1,6	400	15,7	5	363,45	1
F	KLMUBB 40.500 F	40	1,6	500	19,7	5	408,80	1
F	KLMUBB 40.600 F	40	1,6	600	23,6	5	454,17	1
F	KLMUBB 40.700 F	40	1,6	700	27,6	5	499,53	1
F	KLMUBB 40.900 F	40	1,6	900	35,4	5	590,26	1

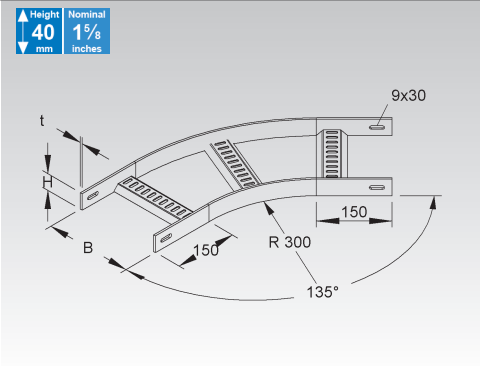

Horizontal Elbow 90°

with integrated splice

	model no.	height H		width B		thick-ness t	Weight per 100 pcs kg	Pack/Box Qty
		mm	Inch	mm	Inch			
F	KLMUB 40.100 F	40	1,6	100	3,9	5	343,77	1
F	KLMUB 40.150 F	40	1,6	150	5,9	5	383,83	1
F	KLMUB 40.200 F	40	1,6	200	7,9	5	423,90	1
F	KLMUB 40.300 F	40	1,6	300	11,8	5	504,00	1
F	KLMUB 40.400 F	40	1,6	400	15,7	5	584,10	1
F	KLMUB 40.500 F	40	1,6	500	19,7	5	664,30	1
F	KLMUB 40.600 F	40	1,6	600	23,6	5	744,40	1
F	KLMUB 40.700 F	40	1,6	700	27,6	5	824,53	1
F	KLMUB 40.900 F	40	1,6	900	35,4	5	984,78	1

Hardware is not included.

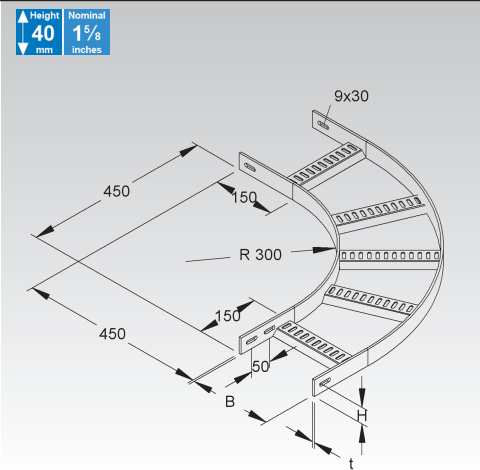

Mushroom Head Bolt

serrated flange nut included

	model no.	thread M	length A		strength category	Weight per 100 pcs kg	Pack/Box Qty
			mm	Inch			
F	FLM 8X25 F	8	25	1	8.8	2,8	50



NOTES

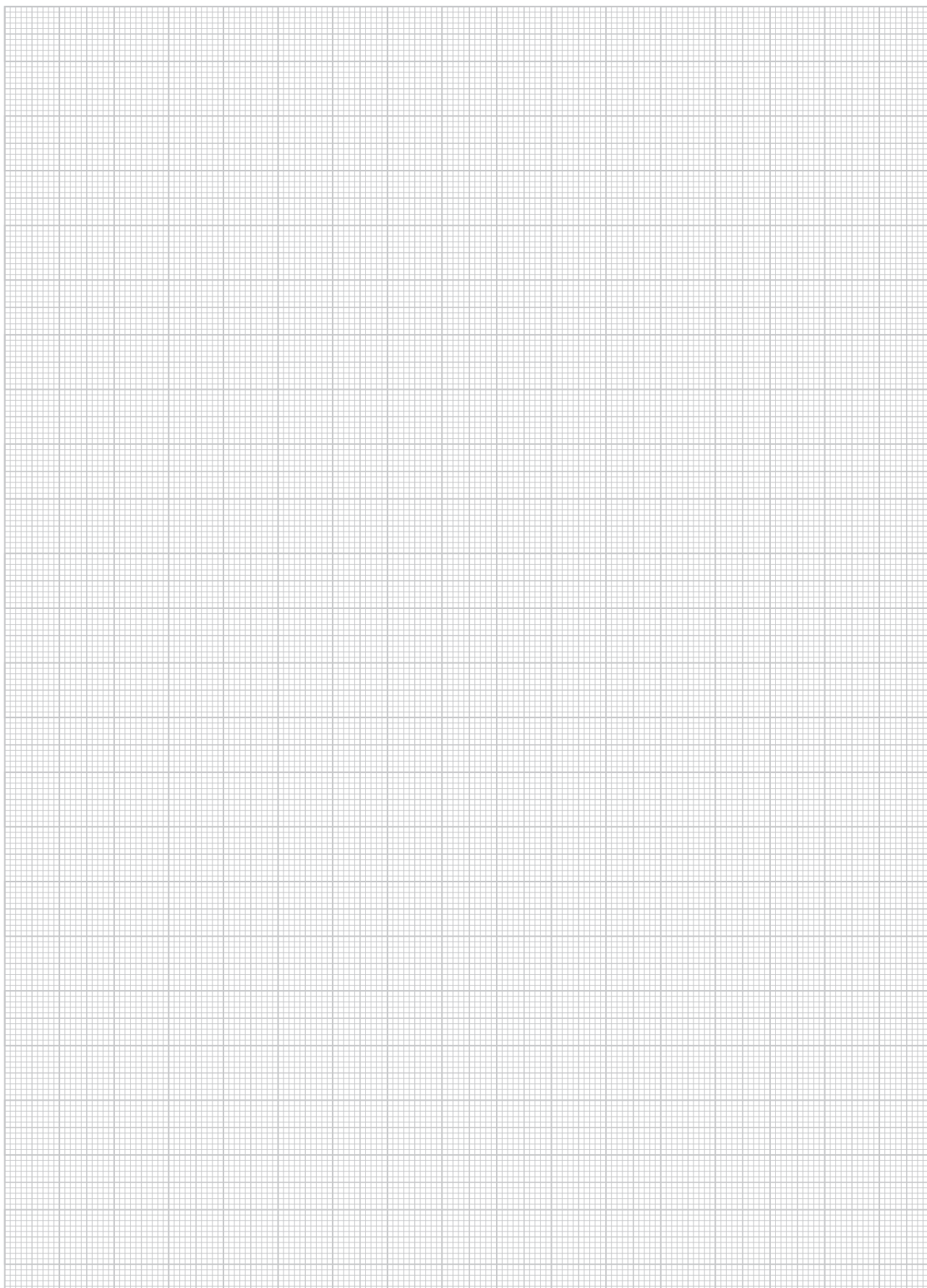

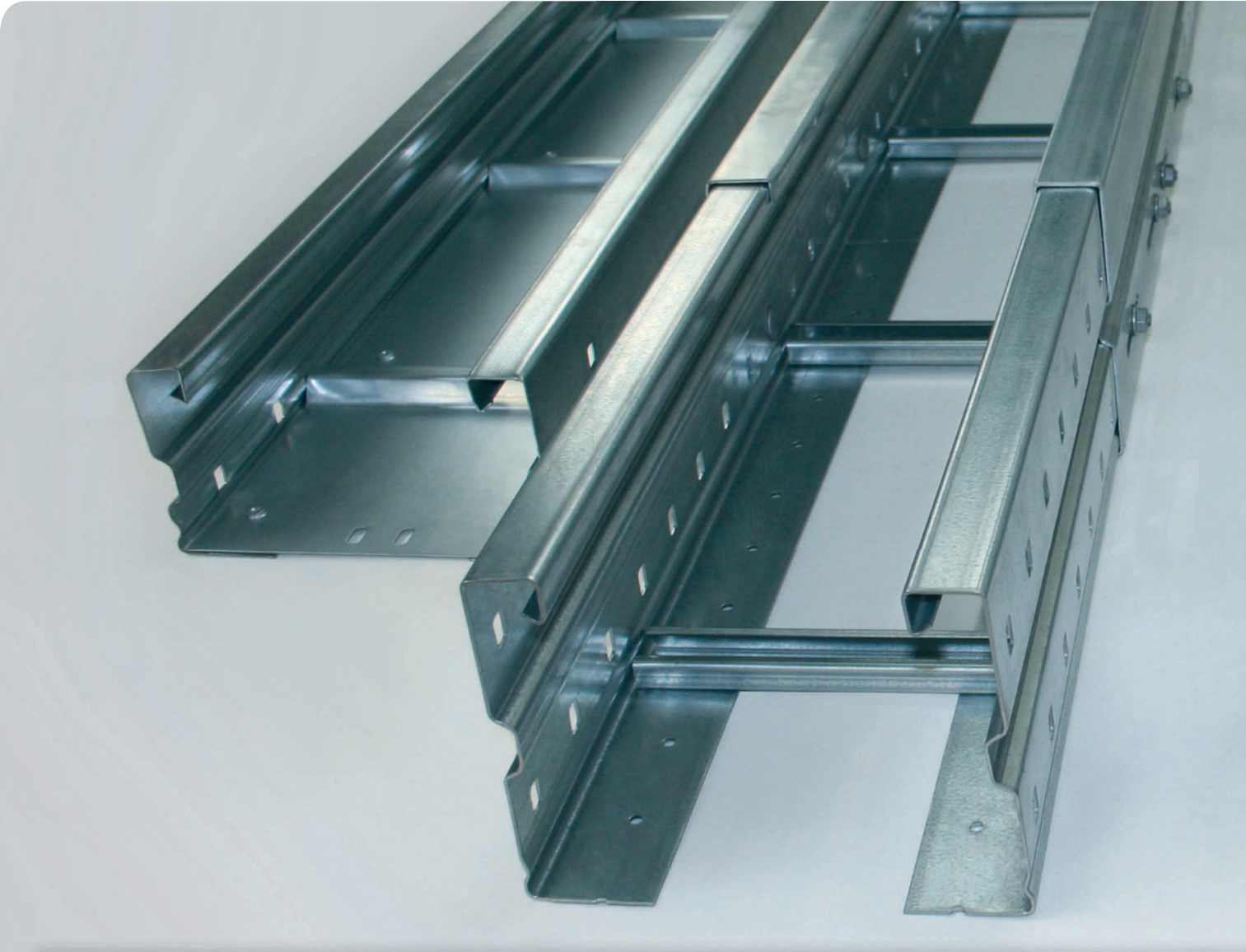

LONG SPAN SYSTEM

- Long Span Cable Tray
- Long Span Cable Ladder
- Fittings
- Accessoires

! Long support spans are causing high load ratings to each individual support. Load capacities shown are valid only for proper anchorage to the building structure. Please consult structural engineering for maximum allowable ratings and special local regulations.



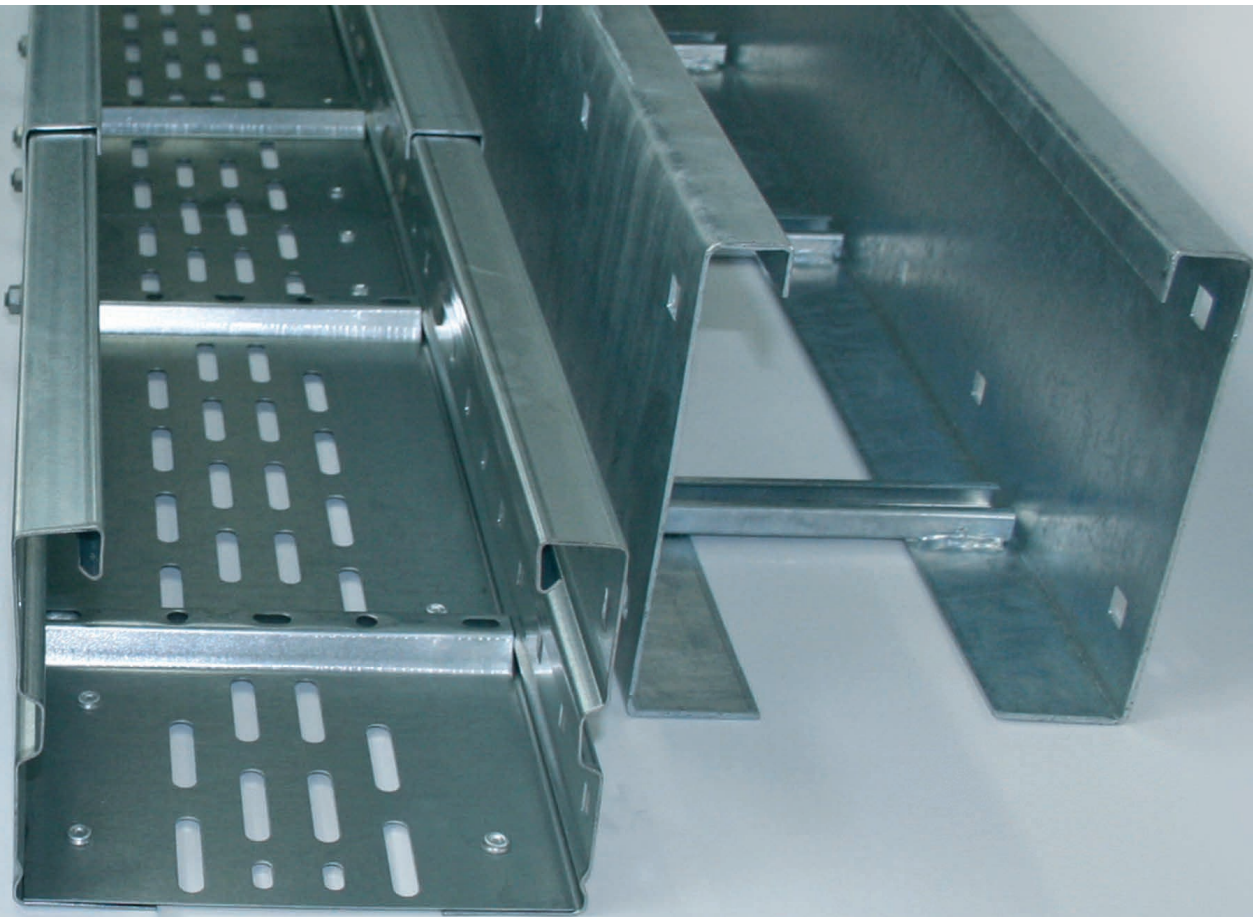

The Long Span System is used where long support spans and high cable load capacities are required. Our heavy duty versions show a load rating of 20C according to NEMA. The main application for Long Span Cable Ladders are heavy duty power cables, while Long Span Trays allow a combination of control- and power cables. Like with all Niedax cable management systems you can select from a wide range of sizes, fittings and accessories in various material thicknesses and finishes.



LONG SPAN CABLE TRAY

Available Side Rail Heights



SYSTEM			↑105 mm	Nominal 4 inches	↑150 mm	Nominal 6 inches
	Long-Span Cable Tray	WRL...	↑105	Page 278	↑150	Page 282
	Long Span Cable Tray	WRU...	↑105	Page 278	↑150	Page 282
	Long-Span Cable Tray, ventilated	WRLM...	↑105	—	↑150	Page 283
ZUBEHÖR	Splice Plate	WSV...	↑105	Page 279	↑150	Page 283
	Adjustable Splice Plate	WSGV...	↑105	Page 279	↑150	Page 283
	Adjustable Splice Plate	WSWV...	↑105	Page 279	↑150	Page 284
	Barrier Strip	RW...		Page 279/284		
	Splice Plate for Barrier Strip	RTV...		Page 279/284		
	Mounting Clamp for Barrier Strip	KLWC 16...		Page 280/284		
	Horizontal Elbow Building Block	WAER...	↑105	Page 280	↑150	Page 284
	Horizontal Elbow 90°	WRBR...	↑105	Page 280	↑150	Page 285
	Extension Horizontal Tee	WRTAR...	↑105	Page 280	↑150	Page 285
	Horizontal Tee	WRTR...	↑105	Page 281	↑150	Page 285
★	Reducer	WSRS...	↑105	Page 281	↑150	Page 286
★	Endplate	WSAS...	↑105	Page 281	↑150	Page 286
	Bottom Connection Plate	RSL...		Page 286		
	Edge Protection Plate	RKB...		Page 286		
	Edge Protection	WBKS 130 E3		Page 287		

Support Span L m	WRL 105...		WRL 150...		WRLM 150...	
	q kN/m	F kN	q kN/m	F kN	q kN/m	F kN
3	2,95	9,15	3,15	9,80	3,45	10,70
4	1,70	7,20	2,40	10,00	2,90	12,10
5	1,00	5,50	1,75	9,30	2,35	12,40
6	0,60	4,20	1,20	7,85	1,85	11,85
7	0,40	3,50	0,85	6,70	1,35	10,30
8	-	-	0,60	5,70	1,00	9,00
9	-	-	-	-	-	-
10	-	-	-	-	-	-
11	-	-	-	-	-	-
12	-	-	-	-	-	-

q = Uniformly distributed load F = Force



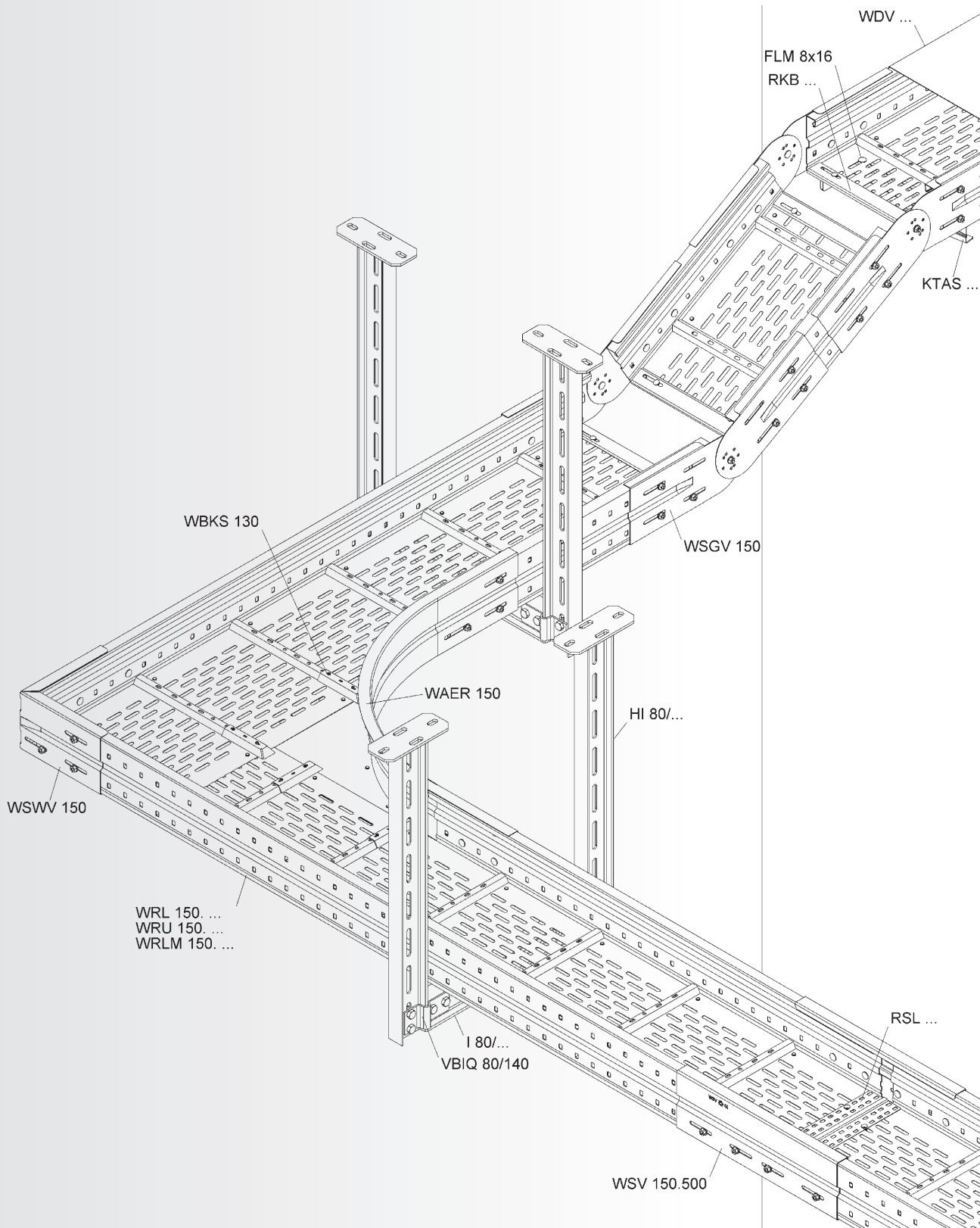

Long Span Cable Tray and Cable Ladder Specifications:

➔ A. CABLE TRAY DESIGN

1. Cable Tray shall be made of straight sections, fittings and accessories as defined in the latest NEMA standards per NEMA VE-1. Standard cable trays shall be UL classified as equipment grounding conductors.

➔ B. MATERIAL

1. **Pre-galvanized steel.** The structural quality of the steel shall meet the minimum yield and tensile strength of the ASTM standards (ASTM A 653) with G 90 coating thickness. All cable trays to be labeled for material identification purposes.
2. **Hot dipped galvanized steel.** All trays to be hot-dipped galvanized in accordance with ASTM A123. All trays to be labeled for material identification.
3. **Stainless steel.** All trays are to be constructed of AISI type 304 or 316 stainless steel. All trays to be labeled for material identification.

➔ C. TRAY TYPES

1. **Ventilated cable tray.** Ventilated trough shall incorporate two side-rails connected by corrugated ventilated metal.
2. **Solid cable tray.** Solid bottom tray shall incorporate two side rails connected by solid steel metal.
3. **Ladder cable tray.** Ladder shall consist of two side-rails with rungs riveted to the bottom flange of the side-rails. Rungs shall be spaced 8" or 12" (200 or 300 mm) on center. Rungs shall not protrude below the bottom of the side-rail.

➔ D. TRAY SIZE

1. **Height:** Trays shall have an overall height of 4", 6", and 8" (105, 150 and 200 mm). Minimum load depth shall be 3.5", 5.5" and 7.5" (90, 135 and 185 mm).
2. **Width:** Widths shall be 8", 12", 16", 20" and 24" (200, 300, 400, 500 and 600 mm).
3. **Length:** Length shall be a nominal 10' or 3 meters, and 20' or 6 meters

➔ E. ACCESSORIES

1. **Covers.** Covers shall be supplied to protect tray cable where needed. Covers will be solid and contain three pair of turn-bolt locks to secure the covers to the lips of the cable tray, requiring only the use of a slotted screwdriver.
2. **Splice plates.** Splice plates shall fasten to the outside of the cable tray side-rails and wrap around and snap onto each section of tray. Bolts and nuts are used to fasten to the tray and are included with splice plates. Plates shall not exceed the NEMA VE-1 resistance of 330 micro ohms.
3. **Other accessories** shall be furnished as required to protect, support, and install a cable tray system. Fittings shall made of the same material as the cable tray whenever possible. Fittings can be of factory construction or also be of a type that allows field constructed fittings.

➔ F. LOADING CAPABILITIES

1. Cable tray shall meet the load/span class designation in accordance with NEMA VE 1 and CSA E22.2 No 126.1. Cable tray shall also meet load/span designation in accordance with IEC 61537

➔ G. DESIGN AND MANUFACTURE

1. Cable tray design shall be manufactured by The Niedax Group.



➔ **Load/Span Class Designation in accordance with NEMA VE 1 and CSA E22.2 No. 126.1**

Niedax Series	Minimum Area		Load class in accordance to NEMA VE 1		
	(calculational) mm ² / in. ²	in accordance to NEMA VE 2 mm ² / in. ²	Rated Load Kg/m / lb./ft.	Support spacing m / ft.	Load/Span Class
WRLX 105.200, ... F, ... E3	627.0 / 0.97	452 / 0.7	80 / 53.8	6 / 19.7	8C, 12C, 16B, D, 20A
WRLX 105.300, ... F, ... E3	627.0 / 0.97	452 / 0.7	80 / 53.8	6 / 19.7	8C, 12C, 16B, D, 20A
WRLX 105.400, ... F, ... E3	627.0 / 0.97	452 / 0.7	80 / 53.8	6 / 19.7	8C, 12C, 16B, D, 20A
WRLX 105.500, ... F, ... E3	627.0 / 0.97	452 / 0.7	80 / 53.8	6 / 19.7	8C, 12C, 16B, D, 20A
WRLX 105.600, ... F, ... E3	627.0 / 0.97	452 / 0.7	80 / 53.8	6 / 19.7	8C, 12C, 16B, D, 20A
WRUX 105.200, ... F	627.0 / 0.97	452 / 0.7	80 / 53.8	6 / 19.7	8C, 12C, 16B, D, 20A
WRUX 105.300, ... F	627.0 / 0.97	452 / 0.7	80 / 53.8	6 / 19.7	8C, 12C, 16B, D, 20A
WRUX 105.400, ... F	627.0 / 0.97	452 / 0.7	80 / 53.8	6 / 19.7	8C, 12C, 16B, D, 20A
WRUX 105.500, ... F	627.0 / 0.97	452 / 0.7	80 / 53.8	6 / 19.7	8C, 12C, 16B, D, 20A
WRUX 105.600, ... F	627.0 / 0.97	452 / 0.7	80 / 53.8	6 / 19.7	8C, 12C, 16B, D, 20A
WRLX 150.200, ... F, ... E3	762.0 / 1.18	645 / 1.0	80 / 53.8	6 / 19.7	8C, 12C, 16B, D, 20A
WRLX 150.300, ... F, ... E3	762.0 / 1.18	645 / 1.0	80 / 53.8	6 / 19.7	8C, 12C, 16B, D, 20A
WRLX 150.400, ... F, ... E3	762.0 / 1.18	645 / 1.0	80 / 53.8	6 / 19.7	8C, 12C, 16B, D, 20A
WRLX 150.500, ... F, ... E3	762.0 / 1.18	645 / 1.0	80 / 53.8	6 / 19.7	8C, 12C, 16B, D, 20A
WRLX 150.600, ... F, ... E3	762.0 / 1.18	645 / 1.0	80 / 53.8	6 / 19.7	8C, 12C, 16B, D, 20A
WRUX 150.200, ... F	762.0 / 1.18	645 / 1.0	80 / 53.8	6 / 19.7	8C, 12C, 16B, D, 20A
WRUX 150.300, ... F	762.0 / 1.18	645 / 1.0	80 / 53.8	6 / 19.7	8C, 12C, 16B, D, 20A
WRUX 150.400, ... F	762.0 / 1.18	645 / 1.0	80 / 53.8	6 / 19.7	8C, 12C, 16B, D, 20A
WRUX 150.500, ... F	762.0 / 1.18	645 / 1.0	80 / 53.8	6 / 19.7	8C, 12C, 16B, D, 20A
WRUX 150.600, ... F	762.0 / 1.18	645 / 1.0	80 / 53.8	6 / 19.7	8C, 12C, 16B, D, 20A
WRLMX 150.200, ... F	896 / 1.39	645 / 1.0	122 / 82	6 / 19.7	8C, 12C, 16B, 20A, E, 20B
WRLMX 150.300, ... F	896 / 1.39	645 / 1.0	122 / 82	6 / 19.7	8C, 12C, 16B, 20A, E, 20B
WRLMX 150.400, ... F	896 / 1.39	645 / 1.0	122 / 82	6 / 19.7	8C, 12C, 16B, 20A, E, 20B
WRLMX 150.500, ... F	896 / 1.39	645 / 1.0	122 / 82	6 / 19.7	8C, 12C, 16B, 20A, E, 20B
WRLMX 150.600, ... F	896 / 1.39	645 / 1.0	122 / 82	6 / 19.7	8C, 12C, 16B, 20A, E, 20B

LONG SPAN CABLE TRAY

Long Span Cable Tray

ventilated bottom

	model no.	height H		width B		length A		thickness t mm	Weight per 100 m kg	Pack/ Box Qty
		mm	Inch	mm	Inch	mm	Inch			
S	WRL 105.200	105	4,1	200	7,9	6000	236,2	1,5	622,87	6 m
S	WRL 105.300	105	4,1	300	11,8	6000	236,2	1,5	683,38	6 m
S	WRL 105.400	105	4,1	400	15,7	6000	236,2	1,5	749,11	6 m
S	WRL 105.500	105	4,1	500	19,7	6000	236,2	1,5	810,98	6 m
S	WRL 105.600	105	4,1	600	23,6	6000	236,2	1,5	929,50	6 m
F	WRL 105.200 F	105	4,1	200	7,9	6000	236,2	1,5	685,32	6 m
F	WRL 105.300 F	105	4,1	300	11,8	6000	236,2	1,5	751,87	6 m
F	WRL 105.400 F	105	4,1	400	15,7	6000	236,2	1,5	824,18	6 m
F	WRL 105.500 F	105	4,1	500	19,7	6000	236,2	1,5	892,25	6 m
F	WRL 105.600 F	105	4,1	600	23,6	6000	236,2	1,5	1.022,63	6 m
E3	WRL 105.200 E3	105	4,1	200	7,9	6000	236,2	1,5	626,97	6 m
E3	WRL 105.300 E3	105	4,1	300	11,8	6000	236,2	1,5	687,87	6 m
E3	WRL 105.400 E3	105	4,1	400	15,7	6000	236,2	1,5	753,62	6 m
E3	WRL 105.500 E3	105	4,1	500	19,7	6000	236,2	1,5	815,77	6 m
E3	WRL 105.600 E3	105	4,1	600	23,6	6000	236,2	1,5	891,94	6 m

Also available in 3 meter length.

A bottom connection plate will be supplied for tray in 400, 500 and 600 mm width.

Load Chart: q = uniformly distributed load (tested according to DIN EN IEC 61537 standard)

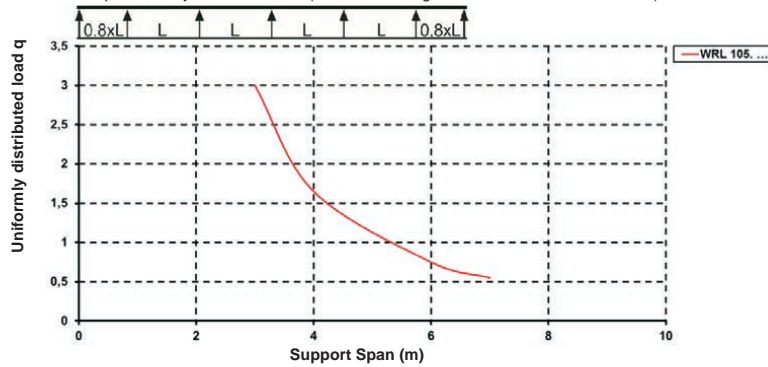

Specified load ratings are independent of splice plate location.

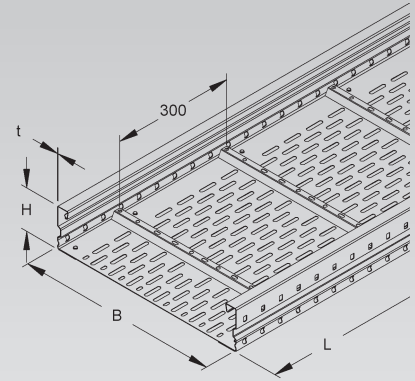
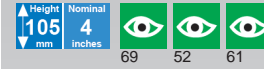

Long Span Cable Tray

solid, but with splice plate perforation

	model no.	height H		width B		length A		thickness t mm	Weight per 100 m kg	Pack/ Box Qty
		mm	Inch	mm	Inch	mm	Inch			
S	WRU 105.200	105	4,1	200	7,9	6000	236,2	1,5	665,14	6 m
S	WRU 105.300	105	4,1	300	11,8	6000	236,2	1,5	748,33	6 m
S	WRU 105.400	105	4,1	400	15,7	6000	236,2	1,5	836,59	6 m
S	WRU 105.500	105	4,1	500	19,7	6000	236,2	1,5	920,94	6 m
S	WRU 105.600	105	4,1	600	23,6	6000	236,2	1,5	1.005,38	6 m
F	WRU 105.200 F	105	4,1	200	7,9	6000	236,2	1,5	731,81	6 m
F	WRU 105.300 F	105	4,1	300	11,8	6000	236,2	1,5	823,35	6 m
F	WRU 105.400 F	105	4,1	400	15,7	6000	236,2	1,5	920,42	6 m
F	WRU 105.500 F	105	4,1	500	19,7	6000	236,2	1,5	1.013,21	6 m
F	WRU 105.600 F	105	4,1	600	23,6	6000	236,2	1,5	1.106,10	6 m

Solid side rails with reinforcing fins, solid bottom plate with reinforcing fins in transverse direction.

Also available in 3 meter length.

A bottom connection plate will be supplied for tray in 400, 500 and 600 mm width.

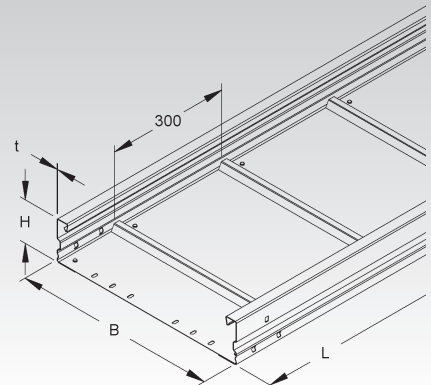

Splice Plate

model no.		inside height H	width B	Weight per 100 pcs kg	Pack/Box Qty
		mm Inch	mm Inch		
S	WSV 105.390	106,5 4,2	390 15,4	116,04	10
F	WSV 105.390 F	106,5 4,2	390 15,4	126,88	10
E3	WSV 105.390 E3	106,5 4,2	390 15,4	117,53	10

form-locking straight splice plate for long span trays and ladders

2 pieces required per joint

UL classified splice plates ensure electrical continuity and proper bonding.

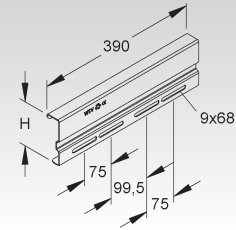
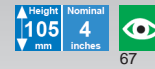

Adjustable Splice Plate

vertical

model no.		inside height H	Weight per 100 pcs kg	Pack/Box Qty
		mm Inch		
S	WSGV 105	106,5 4,2	92,07	1
F	WSGV 105 F	106,5 4,2	99,91	1
E3	WSGV 105 E3	106,5 4,2	92,10	1

2 pieces required per joint

UL classified splice plates ensure electrical continuity and proper bonding.

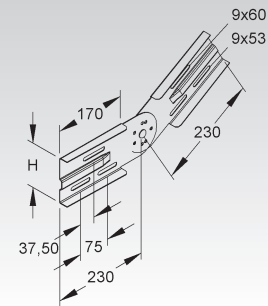
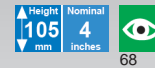

Adjustable Splice Plate

horizontal

model no.		inside height H	width B	Weight per 100 pcs kg	Pack/Box Qty
		mm Inch	mm Inch		
S	WSWV 105.390	106,5 4,2	390 15,4	92,46	10
F	WSWV 105.390 F	106,5 4,2	390 15,4	100,57	10
E3	WSWV 105.390 E3	106,5 4,2	390 15,4	82,33	10

2 pieces required per joint

UL classified splice plates ensure electrical continuity and proper bonding.

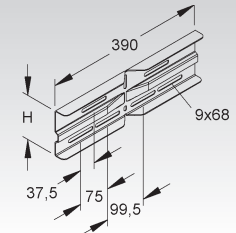

Barrier Strip

model no.		height H	thickness t	Weight per 100 m kg	Pack/Box Qty
		mm Inch	mm		
S	RW 85	80 3,1	0,9	78,39	10 x 3 m
F	RW 85 F	80 3,1	0,9	86,12	10 x 3 m
E3	RW 85 E3	80 3,1	0,9	78,88	10 x 3 m

to separate wires and cables of different voltage levels or with different functions

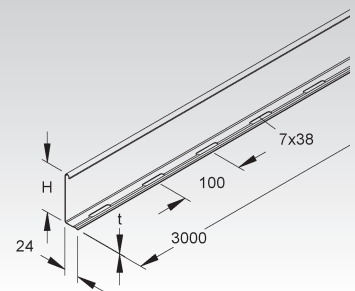
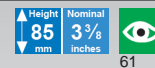

Splice Plate for Barrier Strip

model no.		height H	length A	Weight per 100 pcs kg	Pack/Box Qty
		mm Inch	mm Inch		
E2	RTV 85 E2	79,5 3,1	80 3,1	2,03	20

for positive locking connections and proper bonding of barrier strips

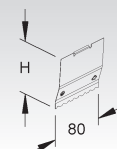
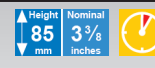

LONG SPAN CABLE TRAY

Mounting Clamp for Barrier Strip

model no.	Weight per 100 pcs kg	Pack/Box Qty
S KLWC 16	2,50	50
F KLWC 16 F	2,69	50
E3 KLWC 16 E3	2,96	50

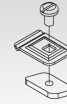

Horizontal Elbow Building Block

with integrated splices

model no.	inside height H mm Inch	Weight per 100 pcs kg	Pack/Box Qty
S WAER 105	106,5 4,2	405,71	1
F WAER 105 F	106,5 4,2	322,60	1
E3 WAER 105 E3	106,5 4,2	366,11	1

for field manufacturing of longspan elbows and tees

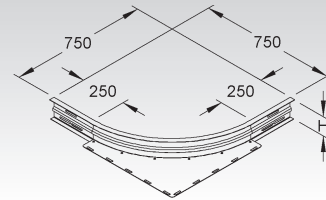

Horizontal Elbow 90°

with solid siderails but prepunched holes for splice plates

model no.	height H mm Inch	width B mm Inch	Weight per 100 pcs kg	Pack/Box Qty
S WRBR 105.200	105 4,1	200 7,9	959,79	1
S WRBR 105.300	105 4,1	300 11,8	1.138,03	1
S WRBR 105.400	105 4,1	400 15,7	1.328,95	1
S WRBR 105.500	105 4,1	500 19,7	1.531,21	1
S WRBR 105.600	105 4,1	600 23,6	1.746,09	1
F WRBR 105.200 F	105 4,1	200 7,9	1.055,77	1
F WRBR 105.300 F	105 4,1	300 11,8	1.251,83	1
F WRBR 105.400 F	105 4,1	400 15,7	1.461,85	1
F WRBR 105.500 F	105 4,1	500 19,7	1.684,33	1
F WRBR 105.600 F	105 4,1	600 23,6	1.920,70	1
E3 WRBR 105.200 E3	105 4,1	200 7,9	966,20	1
E3 WRBR 105.300 E3	105 4,1	300 11,8	1.145,58	1
E3 WRBR 105.400 E3	105 4,1	400 15,7	1.337,71	1
E3 WRBR 105.500 E3	105 4,1	500 19,7	1.541,31	1
E3 WRBR 105.600 E3	105 4,1	600 23,6	1.757,56	1

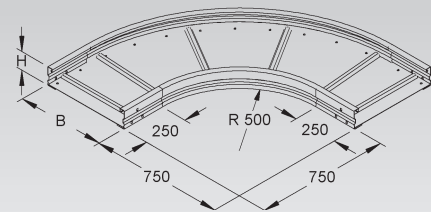

Extension Horizontal Tee

with integrated splices

model no.	inside height H mm Inch	inside dimension (B) mm Inch	Weight per 100 pcs kg	Pack/Box Qty
S WRTAR 105.200	106,5 4,2	205 8,1	1.142,16	1
S WRTAR 105.300	106,5 4,2	305 12	1.210,74	1
S WRTAR 105.400	106,5 4,2	405 15,9	1.279,33	1
S WRTAR 105.500	106,5 4,2	505 19,9	1.347,91	1
S WRTAR 105.600	106,5 4,2	605 23,8	1.416,49	1
F WRTAR 105.200 F	106,5 4,2	205 8,1	1.253,98	1
F WRTAR 105.300 F	106,5 4,2	305 12	1.329,42	1
F WRTAR 105.400 F	106,5 4,2	405 15,9	1.404,86	1
F WRTAR 105.500 F	106,5 4,2	505 19,9	1.480,30	1
F WRTAR 105.600 F	106,5 4,2	605 23,8	1.555,74	1
E3 WRTAR 105.200 E3	106,5 4,2	205 8,1	989,51	1
E3 WRTAR 105.300 E3	106,5 4,2	305 12	1.053,09	1
E3 WRTAR 105.400 E3	106,5 4,2	405 15,9	1.116,67	1
E3 WRTAR 105.500 E3	106,5 4,2	505 19,9	1.273,99	1
E3 WRTAR 105.600 E3	106,5 4,2	605 23,8	1.343,01	1

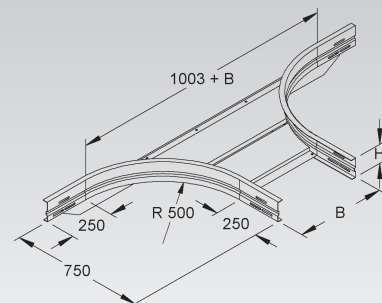

for field manufacturing of horizontal tees and crosses



Horizontal Tee

with solid siderails but prepunched holes for splice plates

	model no.	height H		width B		Weight per 100 pcs kg	Pack/Box Qty
		mm	Inch	mm	Inch		
S	WRTR 105.200	105	4,1	200	7,9	1.594,97	1
S	WRTR 105.300	105	4,1	300	11,8	1.836,73	1
S	WRTR 105.400	105	4,1	400	15,7	2.101,80	1
S	WRTR 105.500	105	4,1	500	19,7	2.374,14	1
S	WRTR 105.600	105	4,1	600	23,6	2.778,54	1
F	WRTR 105.200 F	105	4,1	200	7,9	1.760,64	1
F	WRTR 105.300 F	105	4,1	300	11,8	2.026,52	1
F	WRTR 105.400 F	105	4,1	400	15,7	2.318,10	1
F	WRTR 105.500 F	105	4,1	500	19,7	2.617,66	1
F	WRTR 105.600 F	105	4,1	600	23,6	3.062,58	1
E3	WRTR 105.200 E3	105	4,1	200	7,9	1.605,59	1
E3	WRTR 105.300 E3	105	4,1	300	11,8	1.848,84	1
E3	WRTR 105.400 E3	105	4,1	400	15,7	2.115,60	1
E3	WRTR 105.500 E3	105	4,1	500	19,7	2.389,67	1
E3	WRTR 105.600 E3	105	4,1	600	23,6	2.677,96	1

Height 105 mm
Nominal 4 inches

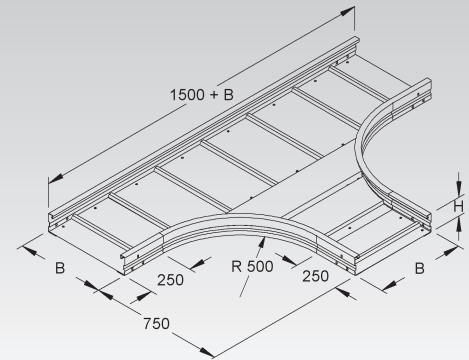

Endplate

	model no.	height H		width B		Weight per 100 kg	Pack/Box Qty
		mm	Inch	mm	Inch		
★ S	WSAS 105.200 S	102	4	200	7,9	51,99	1
★ S	WSAS 105.300 S	102	4	300	11,8	64,00	1
★ S	WSAS 105.400 S	102	4	400	15,7	76,01	1
★ S	WSAS 105.450 S	102	4	450	17,7	80,74	1
★ S	WSAS 105.500 S	102	4	500	19,7	88,02	1
★ S	WSAS 105.600 S	102	4	600	23,6	100,03	1

can be used as blind end or as reducer for longspan cable trays and ladders

Height 105 mm
Nominal 4 inches

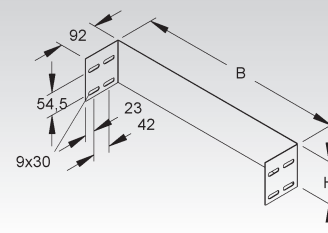

Reducer

	model no.	height H		width B		Weight per 100 kg	Pack/Box Qty
		mm	Inch	mm	Inch		
★ S	WSRS 105.100 S	105	4,1	100	3,9	32,70	1
★ S	WSRS 105.150 S	105	4,1	150	5,9	37,53	1
★ S	WSRS 105.200 S	105	4,1	200	7,9	42,23	1
★ S	WSRS 105.300 S	105	4,1	300	11,8	52,01	1

can be used as a reducer for longspan cable trays and ladders

Height 105 mm
Nominal 4 inches

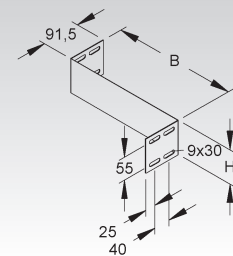

LONG SPAN CABLE TRAY

Long Span Cable Tray

ventilated bottom

	model no.	height H		width B		length A		thick-ness t mm	Weight per 100 m kg	Pack/Box Qty
		mm	Inch	mm	Inch	mm	Inch			
S	WRL 150.200	150	5,9	200	7,9	6000	236,2	1,5	729,33	6 m
S	WRL 150.300	150	5,9	300	11,8	6000	236,2	1,5	789,83	6 m
S	WRL 150.400	150	5,9	400	15,7	6000	236,2	1,5	855,57	6 m
S	WRL 150.500	150	5,9	500	19,7	6000	236,2	1,5	917,43	6 m
S	WRL 150.600	150	5,9	600	23,6	6000	236,2	1,5	1.035,95	6 m
F	WRL 150.200 F	150	5,9	200	7,9	6000	236,2	1,5	802,42	6 m
F	WRL 150.300 F	150	5,9	300	11,8	6000	236,2	1,5	868,98	6 m
F	WRL 150.400 F	150	5,9	400	15,7	6000	236,2	1,5	941,28	6 m
F	WRL 150.500 F	150	5,9	500	19,7	6000	236,2	1,5	1.009,35	6 m
F	WRL 150.600 F	150	5,9	600	23,6	6000	236,2	1,5	1.139,73	6 m
E3	WRL 150.200 E3	150	5,9	200	7,9	6000	236,2	1,5	734,11	6 m
E3	WRL 150.300 E3	150	5,9	300	11,8	6000	236,2	1,5	795,00	6 m
E3	WRL 150.400 E3	150	5,9	400	15,7	6000	236,2	1,5	860,75	6 m
E3	WRL 150.500 E3	150	5,9	500	19,7	6000	236,2	1,5	922,91	6 m
E3	WRL 150.600 E3	150	5,9	600	23,6	6000	236,2	1,5	999,08	6 m

Also available in 3 meter length.

A bottom connection plate will be supplied for tray in 400, 500 and 600 mm width.

Load Chart: q = uniformly distributed load (tested according to DIN EN IEC 61537 standard)

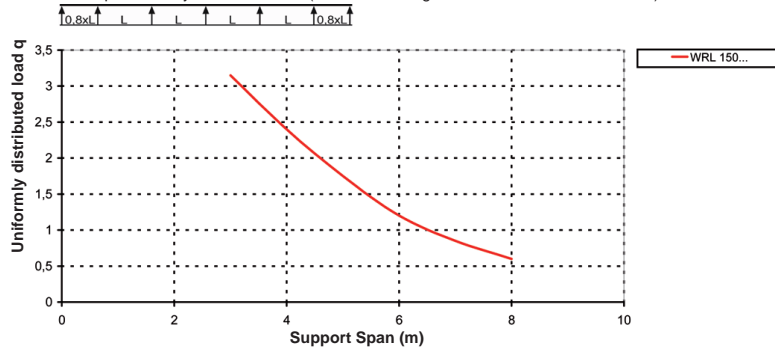

Specified load ratings are independent of splice plate location.

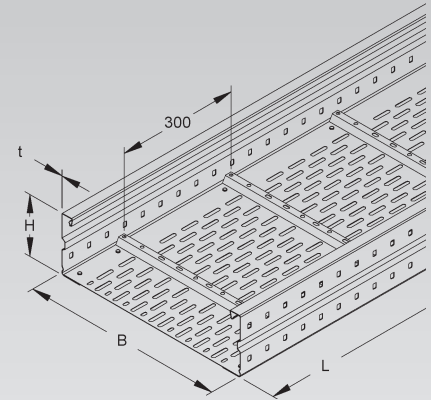
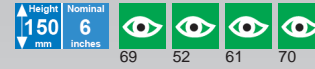

Long Span Cable Tray

solid, but with splice plate perforation

	model no.	height H		width B		length A		thick-ness t mm	Weight per 100 m kg	Pack/Box Qty
		mm	Inch	mm	Inch	mm	Inch			
S	WRU 150.200	150	5,9	200	7,9	6000	236,2	1,5	771,14	6 m
S	WRU 150.300	150	5,9	300	11,8	6000	236,2	1,5	854,33	6 m
S	WRU 150.400	150	5,9	400	15,7	6000	236,2	1,5	942,59	6 m
S	WRU 150.500	150	5,9	500	19,7	6000	236,2	1,5	1.026,94	6 m
S	WRU 150.600	150	5,9	600	23,6	6000	236,2	1,5	1.111,38	6 m
F	WRU 150.200 F	150	5,9	200	7,9	6000	236,2	1,5	848,41	6 m
F	WRU 150.300 F	150	5,9	300	11,8	6000	236,2	1,5	939,93	6 m
F	WRU 150.400 F	150	5,9	400	15,7	6000	236,2	1,5	1.037,01	6 m
F	WRU 150.500 F	150	5,9	500	19,7	6000	236,2	1,5	1.129,81	6 m
F	WRU 150.600 F	150	5,9	600	23,6	6000	236,2	1,5	1.222,70	6 m

Also available in 3 meter length.

A bottom connection plate will be supplied for tray in 400, 500 and 600 mm width.

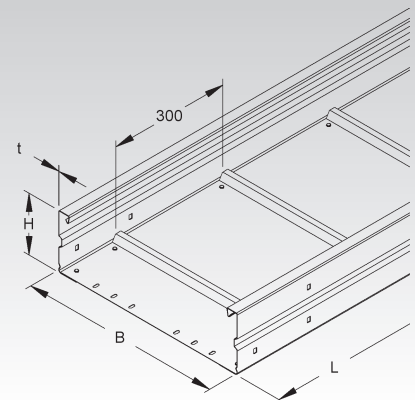

Long Span Cable Tray

with perforated heavy duty siderails

	model no.	height H		width B		length A		thick-ness t	Weight per 100 m	Pack/Box Qty
		mm	Inch	mm	Inch	mm	Inch			
S	WRLM 150.200	150	5,9	200	7,9	6000	236,2	2	923,96	6 m
S	WRLM 150.300	150	5,9	300	11,8	6000	236,2	2	984,46	6 m
S	WRLM 150.400	150	5,9	400	15,7	6000	236,2	2	1.050,20	6 m
S	WRLM 150.500	150	5,9	500	19,7	6000	236,2	2	1.112,07	6 m
S	WRLM 150.600	150	5,9	600	23,6	6000	236,2	2	1.230,59	6 m
F	WRLM 150.200 F	150	5,9	200	7,9	6000	236,2	2	1.016,53	6 m
F	WRLM 150.300 F	150	5,9	300	11,8	6000	236,2	2	1.083,09	6 m
F	WRLM 150.400 F	150	5,9	400	15,7	6000	236,2	2	1.155,39	6 m
F	WRLM 150.500 F	150	5,9	500	19,7	6000	236,2	2	1.223,46	6 m
F	WRLM 150.600 F	150	5,9	600	23,6	6000	236,2	2	1.353,84	6 m

Also available in 3 meter length.

A bottom connection plate will be supplied for tray in 400, 500 and 600 mm width.

Load Chart: q = uniformly distributed load (tested according to DIN EN IEC 61537 standard)

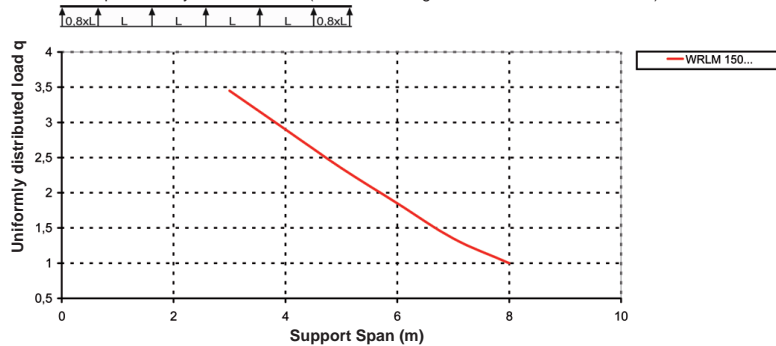

Specified load ratings are independent of splice plate location.

Height 150 mm
Nominal 6 inches

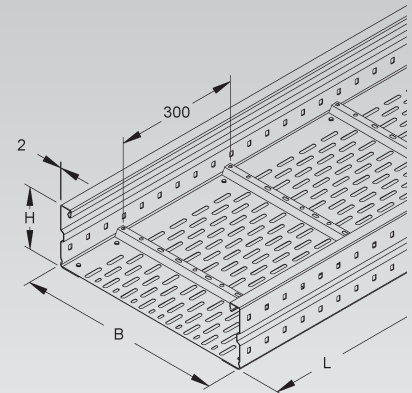

Splice Plate

	model no.	inside height H		width B	Weight per 100 pcs	Pack/Box Qty
		mm	Inch			
S	WSV 150.500	151,5	6	500	19,7	180
F	WSV 150.500 F	151,5	6	500	19,7	202
E3	WSV 150.500 E3	151,5	6	500	19,7	185

form-locking straight splice plate for long span trays and ladders

2 pieces required per joint

UL classified splice plates ensure electrical continuity and proper bonding.

Height 150 mm
Nominal 6 inches



70

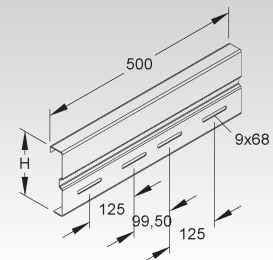

Adjustable Splice Plate

vertical

	model no.	inside height H		Weight per 100 pcs	Pack/Box Qty
		mm	Inch		
S	WSGV 150	151,5	6	151,95	1
F	WSGV 150 F	151,5	6	180,00	1
E3	WSGV 150 E3	151,5	6	152,42	1

2 pieces required per joint

UL classified splice plates ensure electrical continuity and proper bonding.

Height 150 mm
Nominal 6 inches



68

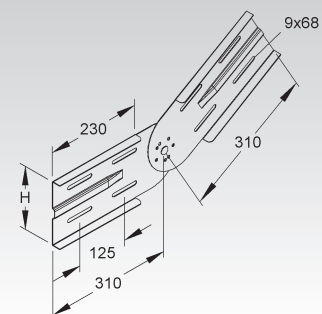

LONG SPAN CABLE TRAY

Adjustable Splice Plate

horizontal

	model no.	inside height H		width B		Weight per 100 pcs kg	Pack/Box Qty
		mm	Inch	mm	Inch		
S	WSWV 150	151,5	6	500	19,7	128,75	10
F	WSWV 150 F	151,5	6	500	19,7	140,49	10
E3	WSWV 150 E3	151,5	6	500	19,7	130,70	10

2 pieces required per joint

UL classified splice plates ensure electrical continuity and proper bonding.

Height
150 mm
Nominal
6 inches

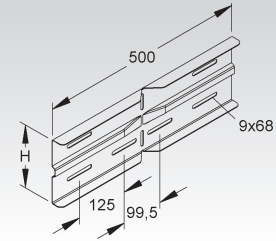

Barrier Strip

	model no.	height H		thickness t	Weight per 100 m kg	Pack/Box Qty
		mm	Inch			
S	RW 110	98	3,9	0,9	90,37	10 x 3 m
F	RW 110 F	98	3,9	0,9	99,30	10 x 3 m
E3	RW 110 E3	98	3,9	0,9	90,94	10 x 3 m

to separate wires and cables of different voltage levels or with different functions

Height
110 mm
Nominal
4 3/8 inches



61

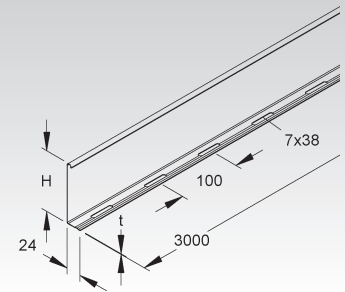

Splice Plate for Barrier Strip

	model no.	height H		length A		Weight per 100 pcs kg	Pack/Box Qty
		mm	Inch	mm	Inch		
E2	RTV 110 E2	97,5	3,8	80	3,1	2,5	20

for positive locking connections and proper bonding of barrier strips

Height
110 mm
Nominal
4 3/8 inches



61

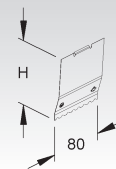

Mounting Clamp for Barrier Strip

	model no.	Weight per 100 pcs kg		Pack/Box Qty
		mm	Inch	
S	KLWC 16	2,50	50	
F	KLWC 16 F	2,69	50	
E3	KLWC 16 E3	2,96	50	



61

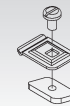

Horizontal Elbow Building Block

with integrated splices

	model no.	inside height H		Weight per 100 pcs kg	Pack/Box Qty
		mm	Inch		
S	WAER 150	151,5	6	431,90	1
F	WAER 150 F	151,5	6	473,90	1
E3	WAER 150 E3	151,5	6	433,11	1

for field manufacturing of longspan elbows and tees

Height
150 mm
Nominal
6 inches

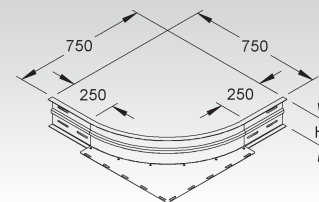

Horizontal Elbow 90°

with solid siderails but prepunched holes for splice plates

	model no.	height H		width B		Weight per 100 pcs kg	Pack/Box Qty
		mm	Inch	mm	Inch		
S	WRBR 150.200	150	5,9	200	7,9	1.115,62	1
S	WRBR 150.300	150	5,9	300	11,8	1.302,20	1
S	WRBR 150.400	150	5,9	400	15,7	1.501,50	1
S	WRBR 150.500	150	5,9	500	19,7	1.712,50	1
S	WRBR 150.600	150	5,9	600	23,6	1.935,70	1
F	WRBR 150.200 F	150	5,9	200	7,9	1.227,20	1
F	WRBR 150.300 F	150	5,9	300	11,8	1.432,40	1
F	WRBR 150.400 F	150	5,9	400	15,7	1.651,60	1
F	WRBR 150.500 F	150	5,9	500	19,7	1.883,80	1
F	WRBR 150.600 F	150	5,9	600	23,6	2.129,30	1
E3	WRBR 150.200 E3	150	5,9	200	7,9	1.120,20	1
E3	WRBR 150.300 E3	150	5,9	300	11,8	1.307,92	1
E3	WRBR 150.400 E3	150	5,9	400	15,7	1.508,50	1
E3	WRBR 150.500 E3	150	5,9	500	19,7	1.720,40	1
E3	WRBR 150.600 E3	150	5,9	600	23,6	1.945,04	1

Height 150 mm
Nominal 6 inches

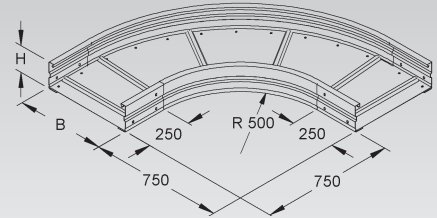

Extension Horizontal Tee

with integrated splices

	model no.	inside height H		inside dimension (B)		Weight per 100 pcs kg	Pack/Box Qty
		mm	Inch	mm	Inch		
S	WRTAR 150.200	151,5	6	205	8,1	1.196,80	1
S	WRTAR 150.300	151,5	6	305	12	1.265,40	1
S	WRTAR 150.400	151,5	6	405	15,9	1.333,90	1
S	WRTAR 150.500	151,5	6	505	19,9	1.402,50	1
S	WRTAR 150.600	151,5	6	605	23,8	1.471,10	1
F	WRTAR 150.200 F	151,5	6	205	8,1	1.314,00	1
F	WRTAR 150.300 F	151,5	6	305	12	1.389,50	1
F	WRTAR 150.400 F	151,5	6	405	15,9	1.464,90	1
F	WRTAR 150.500 F	151,5	6	505	19,9	1.540,40	1
F	WRTAR 150.600 F	151,5	6	605	23,8	1.615,80	1
E3	WRTAR 150.200 E3	151,5	6	205	8,1	1.123,50	1
E3	WRTAR 150.300 E3	151,5	6	305	12	1.189,49	1
E3	WRTAR 150.400 E3	151,5	6	405	15,9	1.250,70	1
E3	WRTAR 150.500 E3	151,5	6	505	19,9	1.495,70	1
E3	WRTAR 150.600 E3	151,5	6	605	23,8	1.479,41	1

Height 150 mm
Nominal 6 inches
69

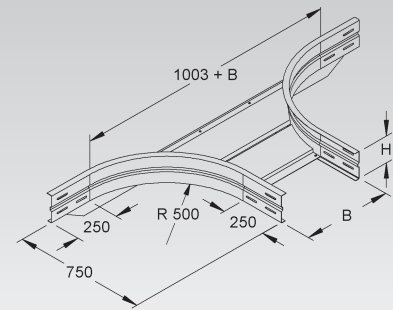

for field manufacturing of horizontal tees and crosses

Horizontal Tee

with solid siderails but prepunched holes for splice plates

	model no.	height H		width B		Weight per 100 pcs kg	Pack/Box Qty
		mm	Inch	mm	Inch		
S	WRTR 150.200	150	5,9	200	7,9	1.826,71	1
S	WRTR 150.300	150	5,9	300	11,8	2.074,21	1
S	WRTR 150.400	150	5,9	400	15,7	2.344,60	1
S	WRTR 150.500	150	5,9	500	19,7	2.622,21	1
S	WRTR 150.600	150	5,9	600	23,6	3.031,98	1
F	WRTR 150.200 F	150	5,9	200	7,9	2.009,90	1
F	WRTR 150.300 F	150	5,9	300	11,8	2.281,60	1
F	WRTR 150.400 F	150	5,9	400	15,7	2.579,00	1
F	WRTR 150.500 F	150	5,9	500	19,7	2.884,40	1
F	WRTR 150.600 F	150	5,9	600	23,6	3.335,20	1
E3	WRTR 150.200 E3	150	5,9	200	7,9	1.833,77	1
E3	WRTR 150.300 E3	150	5,9	300	11,8	2.082,30	1
E3	WRTR 150.400 E3	150	5,9	400	15,7	2.354,40	1
E3	WRTR 150.500 E3	150	5,9	500	19,7	2.633,80	1
E3	WRTR 150.600 E3	150	5,9	600	23,6	2.927,40	1

Height 150 mm
Nominal 6 inches

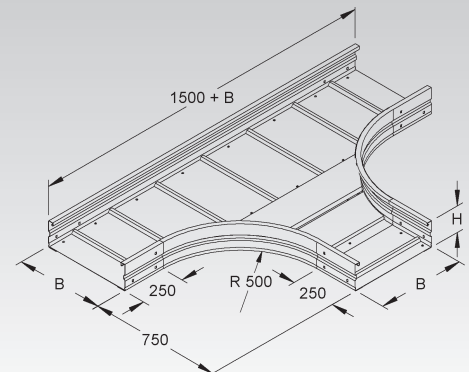

LONG SPAN CABLE TRAY

Reducer

model no.	height H		width B		Weight per 100 pcs kg	Pack/Box Qty
	mm	Inch	mm	Inch		
★ S WSR5 150.100 S	150	5,9	100	3,9	53,61	1
★ S WSR5 150.150 S	150	5,9	150	5,9	62,20	1
★ S WSR5 150.200 S	150	5,9	200	7,9	70,80	1
★ S WSR5 150.300 S	150	5,9	300	11,8	87,99	1

can be used as a reducer for longspan cable trays and ladders

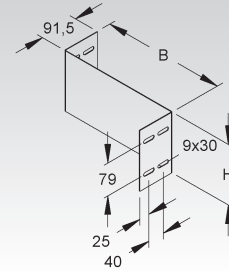
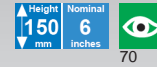

Endplate

model no.	height H		width B		Weight per 100 pcs kg	Pack/Box Qty
	mm	Inch	mm	Inch		
★ S WSAS 150.200 S	150	5,9	200	7,9	70	1
★ S WSAS 150.300 S	150	5,9	300	11,8	90	1
★ S WSAS 150.400 S	150	5,9	400	15,7	100	1
★ S WSAS 150.450 S	150	5,9	450	17,7	108	1
★ S WSAS 150.500 S	150	5,9	500	19,7	117	1
★ S WSAS 150.600 S	150	5,9	600	23,6	123	1
★ S WSAS 150.900 S	150	5,9	900	35,4	192	1

can be used as blind end or as reducer for longspan cable trays and ladders

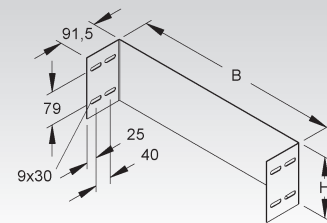
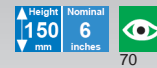

Bottom Connection Plate

model no.	width B		Weight per 100 pcs kg	Pack/Box Qty
	mm	Inch		
S RSL 400	389	15,3	30,06	1
S RSL 500	489	19,3	37,00	1
S RSL 600	589	23,2	43,94	1
F RSL 400 F	389	15,3	33,15	1
F RSL 500 F	489	19,3	40,78	1
F RSL 600 F	589	23,2	48,41	1
E3 RSL 400 E3	389	15,3	27,97	1
E3 RSL 500 E3	489	19,3	34,26	1
E3 RSL 600 E3	589	23,2	40,54	1

to stabilize bottom plate joints of long span trays (required only for tray width 400 mm and up)

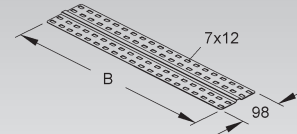

Edge Protection Plate

model no.	width B		Weight per 100 pcs kg	Pack/Box Qty
	mm	Inch		
S RKB 200	192	7,6	8,77	10
S RKB 300	292	11,5	12,84	10
S RKB 400	392	15,4	16,91	10
S RKB 500	492	19,4	20,98	10
S RKB 600	592	23,3	25,05	10
F RKB 200 F	192	7,6	9,69	50
F RKB 300 F	292	11,5	14,16	50
F RKB 400 F	392	15,4	18,64	50
F RKB 500 F	492	19,4	23,12	50
F RKB 600 F	592	23,3	27,60	50
E3 RKB 200 E3	192	7,6	9,04	10
E3 RKB 300 E3	292	11,5	13,13	10
E3 RKB 400 E3	392	15,4	17,23	10
E3 RKB 600 E3	592	23,3	25,42	10

with rounded edges to protect cables at the joint and to reinforce the bottom of cable trays

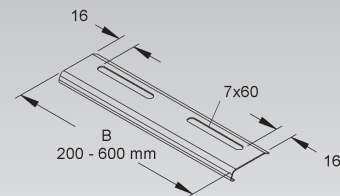

Edge Protection

2 self tapping screws included

model no.	color	Weight per 100 pcs kg	Pack/Box Qty
K04 WBKS 130 E3	grey	1,42	20

protective end cap





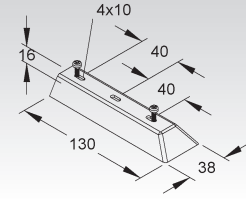















69



LONG SPAN CABLE LADDER

Available Side Rail Heights

SYSTEM		WSL...		Page 291		Page 295
	Long Span Cable Ladder	WSLM...		—		Page 296
ZUBEHÖR	Splice Plate	WSV...		Page 291		Page 296
	Adjustable Splice Plate	WSGV...		Page 291		Page 296
	Adjustable Splice Plate	WSWV...		Page 292		Page 297
	Horizontal Elbow Building Block	WAER...		Page 292		Page 297
	Horizontal Elbow 90°	WSBR...		Page 293		Page 298
	Extension Horizontal Tee	WSTAR...		Page 293		Page 298
	Horizontal Tee	WSTR...		Page 294		Page 299
	Pair of Protective End Caps	SKWHM 105		Page 294		
	Barrier Strip	RW...		Page 292/297		
	Splice Plate for Barrier Strip	RTV...		Page 292/297		
	Mounting Clamp for Barrier Strip	KLWC...		Page 292/297		
★	Reducer	WSRS...		Page 299		
★	Endplate	WSAS...		Page 299		
	Ladder Drop Out	WLAB...		Page 300		
	Mounting Clamp for Long Span Ladders	WSTB...		Page 300		
	Two Hole Corner Angle	WWU...		Page 300		
	Three Hole Corner Angle	WWA...		Page 300		
	Cover for Long Span Cable Trays/Ladders	WDV...		Page 301		
	Cover for 90° Horizontal Elbow	WBRDV...		Page 301		
	Cover for Horizontal Extension Tee	WTARDV...		Page 302		
	Cover for Horizontal Tee	WTRDV...		Page 302		
	Turnbolt Lock	WDRS...		Page 302		

Befestigungsabst. L m	WSL 105...		WSL 150...		WSLM 150...	
	q kN/m	F kN	q kN/m	F kN	q kN/m	F kN
3	2,95	9,05	3,15	9,70	3,45	10,65
4	1,70	7,05	2,30	9,50	2,60	10,80
5	1,00	5,35	1,45	7,60	2,00	10,50
6	0,60	4,00	0,85	5,55	1,50	9,60
7	0,40	3,25	0,55	4,35	1,15	8,75
8	-	-	0,40	3,80	0,90	8,00
9	-	-	-	-	-	-
10	-	-	-	-	-	-
11	-	-	-	-	-	-
12	-	-	-	-	-	-

q = Uniformly distributed load F = Force



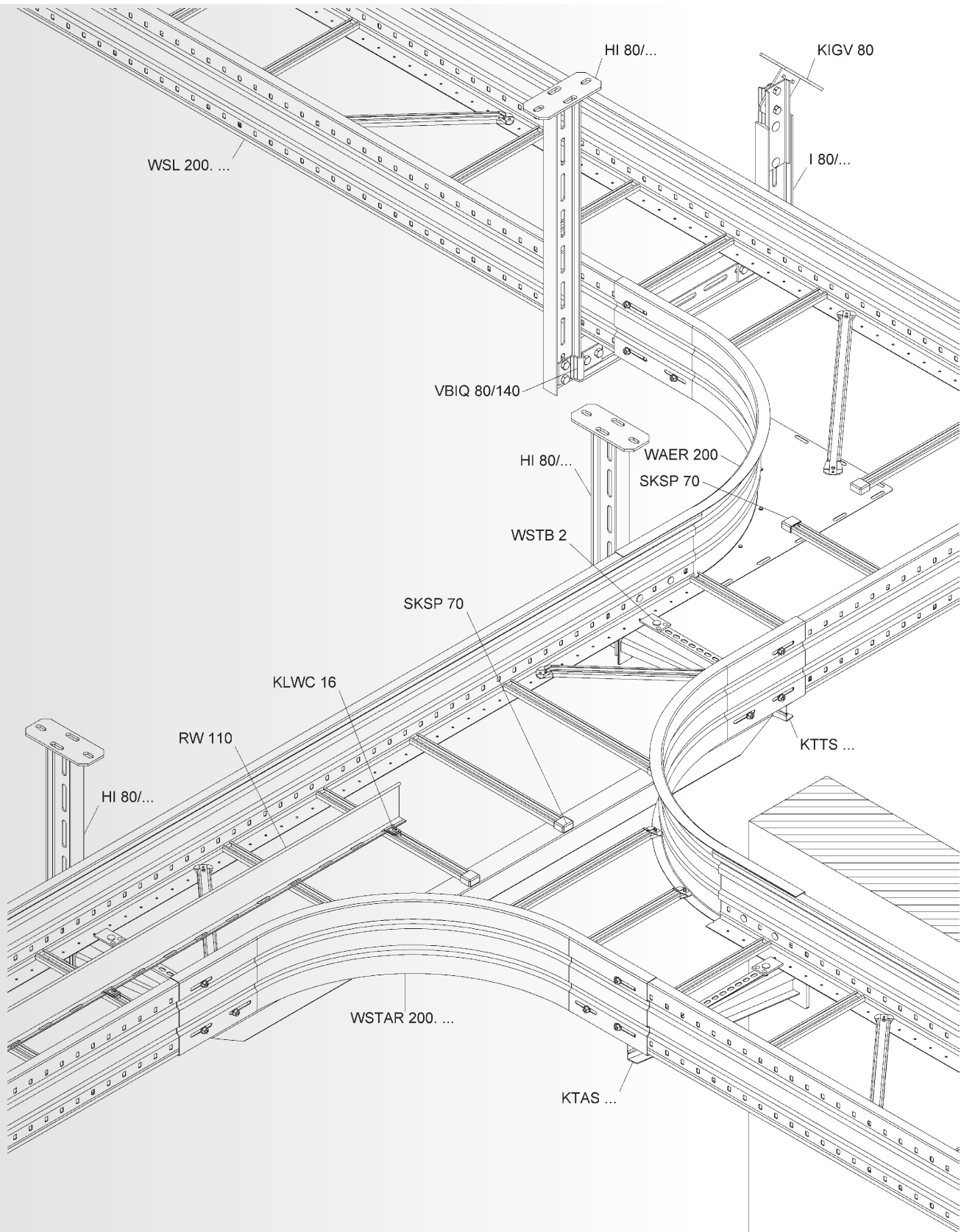

LONG SPAN CABLE LADDER

 **Load/Span Class Designation in accordance with NEMA VE 1 and CSA E22.2 No. 126.1**

Niedax Series	Minimum Area		Load class in accordance to NEMA VE 1		
	(calculational) mm ² / in. ²	in accordance to NEMA VE 2 mm ² / in. ²	Rated Load Kg/m / lb./ft.	Support spacing m / ft.	Load/Span Class
WSLX 105.200, ... F, ... E3	627.0 / 0.97	452 / 0.7	67 / 45	6 / 19.7	12C, 16A, C
WSLX 105.300, ... F, ... E3	627.0 / 0.97	452 / 0.7	67 / 45	6 / 19.7	12C, 16A, C
WSLX 105.400, ... F, ... E3	627.0 / 0.97	452 / 0.7	67 / 45	6 / 19.7	12C, 16A, C
WSLX 105.450, ... F	627.0 / 0.97	452 / 0.7	67 / 45	6 / 19.7	12C, 16A, C
WSLX 105.500, ... F, ... E3	627.0 / 0.97	452 / 0.7	67 / 45	6 / 19.7	12C, 16A, C
WSLX 105.600, ... F, ... E3	627.0 / 0.97	452 / 0.7	67 / 45	6 / 19.7	12C, 16A, C
WSLX 150.200, ... F, ... E3	762.0 / 1.18	645 / 1.0	73.0 / 49	6 / 19.7	12C, 20AA, D
WSLX 150.300, ... F, ... E3	762.0 / 1.18	645 / 1.0	73.0 / 49	6 / 19.7	12C, 20AA, D
WSLX 150.400, ... F, ... E3	762.0 / 1.18	645 / 1.0	73.0 / 49	6 / 19.7	12C, 20AA, D
WSLX 150.450, ... F	762.0 / 1.18	645 / 1.0	73.0 / 49	6 / 19.7	12C, 20AA, D
WSLX 150.500, ... F, ... E3	762.0 / 1.18	645 / 1.0	73.0 / 49	6 / 19.7	12C, 20AA, D
WSLX 150.600, ... F, ... E3	762.0 / 1.18	645 / 1.0	73.0 / 49	6 / 19.7	12C, 20AA, D
WSLX 150.900, ... F	762.0 / 1.18	645 / 1.0	73.0 / 49	6 / 19.7	12C, 20AA, D
WSLMX 150.200, ... F	896 / 1.39	645 / 1.0	122 / 82	6 / 19.7	16C, 20B, E
WSLMX 150.300, ... F	896 / 1.39	645 / 1.0	122 / 82	6 / 19.7	16C, 20B, E
WSLMX 150.400, ... F	896 / 1.39	645 / 1.0	122 / 82	6 / 19.7	16C, 20B, E
WSLMX 150.450, ... F	896 / 1.39	645 / 1.0	122 / 82	6 / 19.7	16C, 20B, E
WSLMX 150.500, ... F	896 / 1.39	645 / 1.0	122 / 82	6 / 19.7	16C, 20B, E
WSLMX 150.600, ... F	896 / 1.39	645 / 1.0	122 / 82	6 / 19.7	16C, 20B, E
WSLMX 150.900, ... F	896 / 1.39	645 / 1.0	122 / 82	6 / 19.7	16C, 20B, E



Long Span Cable Ladder

C-channel rungs with 16 mm slot width, standard spacing 300 mm

	model no.	height H		width B		length A		thick-ness t mm	Weight per 100 m kg	Pack/Box Qty
		mm	Inch	mm	Inch	mm	Inch			
S	WSL 105.200	105	4,1	200	7,9	6000	236,2	1,5	534,00	6 m
S	WSL 105.300	105	4,1	300	11,8	6000	236,2	1,5	559,00	6 m
S	WSL 105.400	105	4,1	400	15,7	6000	236,2	1,5	584,00	6 m
S	WSL 105.450	105	4,1	450	17,7	6000	236,2	1,5	613,18	6 m
S	WSL 105.500	105	4,1	500	19,7	6000	236,2	1,5	609,00	6 m
S	WSL 105.600	105	4,1	600	23,6	6000	236,2	1,5	634,00	6 m
F	WSL 105.200 F	105	4,1	200	7,9	6000	236,2	1,5	599,59	6 m
F	WSL 105.300 F	105	4,1	300	11,8	6000	236,2	1,5	629,55	6 m
F	WSL 105.400 F	105	4,1	400	15,7	6000	236,2	1,5	659,51	6 m
F	WSL 105.450 F	105	4,1	450	17,7	6000	236,2	1,5	674,50	6 m
F	WSL 105.500 F	105	4,1	500	19,7	6000	236,2	1,5	687,56	6 m
F	WSL 105.600 F	105	4,1	600	23,6	6000	236,2	1,5	717,51	6 m
E3	WSL 105.200 E3	105	4,1	200	7,9	6000	236,2	1,5	534,00	6 m
E3	WSL 105.300 E3	105	4,1	300	11,8	6000	236,2	1,5	559,00	6 m
E3	WSL 105.400 E3	105	4,1	400	15,7	6000	236,2	1,5	584,00	6 m
E3	WSL 105.500 E3	105	4,1	500	19,7	6000	236,2	1,5	609,00	6 m
E3	WSL 105.600 E3	105	4,1	600	23,6	6000	236,2	1,5	634,00	6 m

Also available in 3 meter length.

Load Chart: q = uniformly distributed load (tested according to DIN EN IEC 61537 standard)

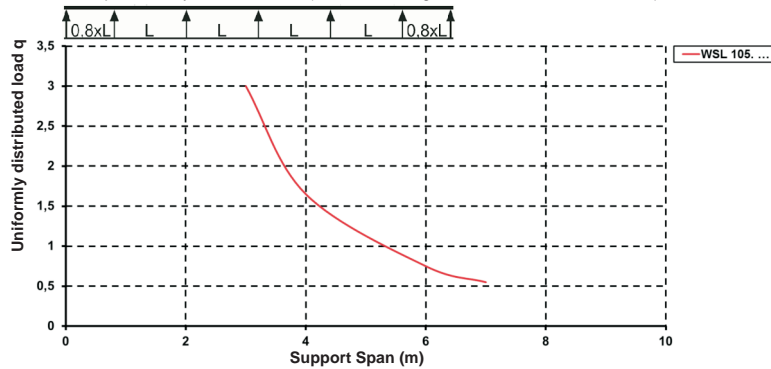

Specified load ratings are independent of splice plate location.

Height 105 mm	Nominal 4 inches			
		61	68	67

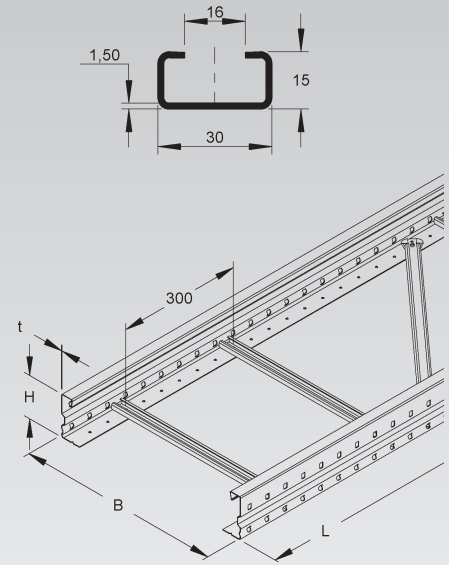

Splice Plate

	model no.	inside height H		width B		Weight per 100 pcs kg	Pack/Box Qty
		mm	Inch	mm	Inch		
S	WSV 105.390	106,5	4,2	390	15,4	116,04	10
F	WSV 105.390 F	106,5	4,2	390	15,4	126,88	10
E3	WSV 105.390 E3	106,5	4,2	390	15,4	117,53	10

form-locking straight splice plate for long span trays and ladders

2 pieces required per joint

UL classified splice plates ensure electrical continuity and proper bonding.

Height 105 mm	Nominal 4 inches	
		67

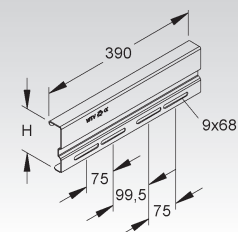

Adjustable Splice Plate

vertical

	model no.	inside height H		Weight per 100 pcs kg	Pack/Box Qty
		mm	Inch		
S	WSGV 105	106,5	4,2	92,07	1
F	WSGV 105 F	106,5	4,2	99,91	1
E3	WSGV 105 E3	106,5	4,2	92,10	1

2 pieces required per joint

UL classified splice plates ensure electrical continuity and proper bonding.

Height 105 mm	Nominal 4 inches	
		68

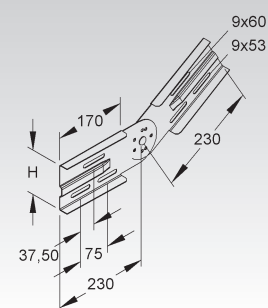

LONG SPAN CABLE LADDER

Adjustable Splice Plate

horizontal

	model no.	inside height H		width B		Weight per 100 pcs kg	Pack/Box Qty
		mm	Inch	mm	Inch		
S	WSWV 105.390	106,5	4,2	390	15,4	92,46	10
F	WSWV 105.390 F	106,5	4,2	390	15,4	100,57	10
E3	WSWV 105.390 E3	106,5	4,2	390	15,4	82,33	10

2 pieces required per joint

UL classified splice plates ensure electrical continuity and proper bonding.

Height
105 mm
Nominal
4 inches

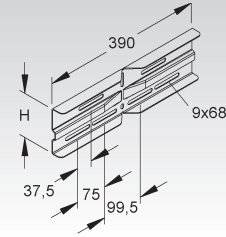

Barrier Strip

	model no.	height H	thickness t	Weight per 100 m kg	Pack/Box Qty	
						mm
S	RW 85	80	3,1	0,9	78,39	10 x 3 m
F	RW 85 F	80	3,1	0,9	86,12	10 x 3 m
E3	RW 85 E3	80	3,1	0,9	78,88	10 x 3 m

to separate wires and cables of different voltage levels or with different functions

Height
85 mm
Nominal
3 3/8 inches



61

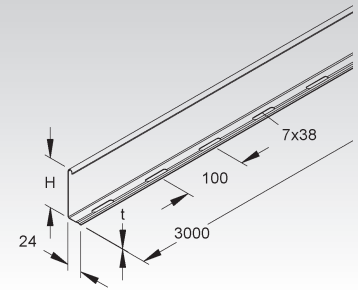

Splice Plate for Barrier Strip

	model no.	height H	length A		Weight per 100 pcs kg	Pack/Box Qty	
			mm	Inch			mm
E2	RTV 85 E2	79,5	3,1	80	3,1	2,03	20

for positive locking connections and proper bonding of barrier strips

Height
85 mm
Nominal
3 3/8 inches



61

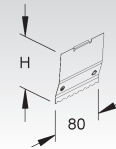

Mounting Clamp for Barrier Strip

	model no.	Weight per 100 pcs kg	Pack/Box Qty
F	KLWC 16 F	2,69	50
E3	KLWC 16 E3	2,96	50



61

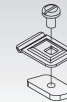

Horizontal Elbow Building Block

with integrated splices

	model no.	inside height H		Weight per 100 pcs kg	Pack/Box Qty
		mm	Inch		
S	WAER 105	106,5	4,2	405,71	1
F	WAER 105 F	106,5	4,2	322,60	1
E3	WAER 105 E3	106,5	4,2	366,11	1

for field manufacturing of longspan elbows and tees

Height
105 mm
Nominal
4 inches

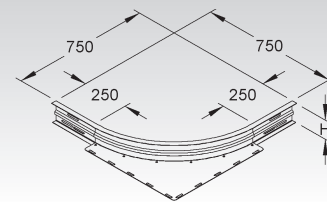

Horizontal Elbow 90°

with solid siderails but prepunched holes for splice plates

	model no.	height H		width B		Weight per 100 pcs kg	Pack/Box Qty
		mm	Inch	mm	Inch		
S	WSBR 105.200	105	4,1	200	7,9	828,88	1
S	WSBR 105.300	105	4,1	300	11,8	921,49	1
S	WSBR 105.400	105	4,1	400	15,7	1.014,06	1
S	WSBR 105.450	105	4,1	450	17,7	1.060,05	1
S	WSBR 105.500	105	4,1	500	19,7	1.106,70	1
S	WSBR 105.600	105	4,1	600	23,6	1.199,30	1
F	WSBR 105.200 F	105	4,1	200	7,9	911,77	1
F	WSBR 105.300 F	105	4,1	300	11,8	1.013,64	1
F	WSBR 105.400 F	105	4,1	400	15,7	1.115,46	1
F	WSBR 105.450 F	105	4,1	450	17,7	1.166,06	1
F	WSBR 105.500 F	105	4,1	500	19,7	1.217,37	1
F	WSBR 105.600 F	105	4,1	600	23,6	1.319,30	1
E3	WSBR 105.200 E3	105	4,1	200	7,9	834,16	1
E3	WSBR 105.300 E3	105	4,1	300	11,8	927,35	1
E3	WSBR 105.400 E3	105	4,1	400	15,7	1.020,51	1
E3	WSBR 105.500 E3	105	4,1	500	19,7	1.113,74	1
E3	WSBR 105.600 E3	105	4,1	600	23,6	1.206,93	1

WSV 105.390 splice plates have to be ordered separately.

Height 105 mm
Nominal 4 inches
67

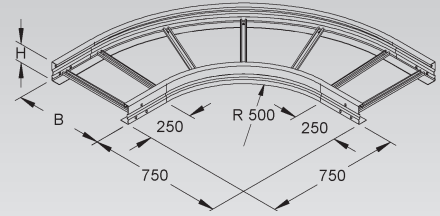

Extension Horizontal Tee

with integrated splices

	model no.	inside height H		inside dimension (B)		Weight per 100 pcs kg	Pack/Box Qty
		mm	Inch	mm	Inch		
S	WSTAR 105.200	106,5	4,2	205	8,1	972,12	1
S	WSTAR 105.300	106,5	4,2	305	12	1.008,76	1
S	WSTAR 105.400	106,5	4,2	405	15,9	1.046,39	1
S	WSTAR 105.450	106,5	4,2	455	17,9	1.065,28	1
S	WSTAR 105.500	106,5	4,2	505	19,9	1.085,75	1
S	WSTAR 105.600	106,5	4,2	605	23,8	1.118,10	1
F	WSTAR 105.200 F	106,5	4,2	205	8,1	1.066,93	1
F	WSTAR 105.300 F	106,5	4,2	305	12	1.107,24	1
F	WSTAR 105.400 F	106,5	4,2	405	15,9	1.148,63	1
F	WSTAR 105.450 F	106,5	4,2	455	17,9	1.169,40	1
F	WSTAR 105.500 F	106,5	4,2	505	19,9	1.191,93	1
F	WSTAR 105.600 F	106,5	4,2	605	23,8	1.227,51	1
E3	WSTAR 105.200 E3	106,5	4,2	205	8,1	817,47	1
E3	WSTAR 105.300 E3	106,5	4,2	305	12	849,07	1
E3	WSTAR 105.400 E3	106,5	4,2	405	15,9	880,67	1
E3	WSTAR 105.500 E3	106,5	4,2	505	19,9	1.009,13	1
E3	WSTAR 105.600 E3	106,5	4,2	605	23,8	1.041,21	1

for field manufacturing of horizontal tees and crosses

Height 105 mm
Nominal 4 inches
69

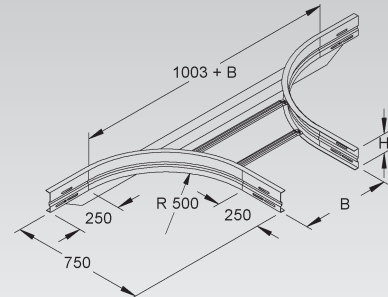

LONG SPAN CABLE LADDER

Horizontal Tee

with solid siderails but prepunched holes for splice plates

	model no.	height H		width B		Weight per 100 pcs kg	Pack/ Box Qty
		mm	Inch	mm	Inch		
S	WSTR 105.200	105	4,1	200	7,9	1.322,15	1
S	WSTR 105.300	105	4,1	300	11,8	1.422,99	1
S	WSTR 105.400	105	4,1	400	15,7	1.581,44	1
S	WSTR 105.450	105	4,1	450	17,7	1.638,88	1
S	WSTR 105.500	105	4,1	500	19,7	1.772,37	1
S	WSTR 105.600	105	4,1	600	23,6	1.895,48	1
F	WSTR 105.200 F	105	4,1	200	7,9	1.454,37	1
F	WSTR 105.300 F	105	4,1	300	11,8	1.565,29	1
F	WSTR 105.400 F	105	4,1	400	15,7	1.739,59	1
F	WSTR 105.450 F	105	4,1	450	17,7	1.802,77	1
F	WSTR 105.500 F	105	4,1	500	19,7	1.949,61	1
F	WSTR 105.600 F	105	4,1	600	23,6	2.085,02	1
E3	WSTR 105.200 E3	105	4,1	200	7,9	1.330,57	1
E3	WSTR 105.300 E3	105	4,1	300	11,8	1.432,05	1
E3	WSTR 105.400 E3	105	4,1	400	15,7	1.591,51	1
E3	WSTR 105.500 E3	105	4,1	500	19,7	1.783,65	1
E3	WSTR 105.600 E3	105	4,1	600	23,6	1.907,54	1

WSV 105.390 splice plates have to be ordered separatly.

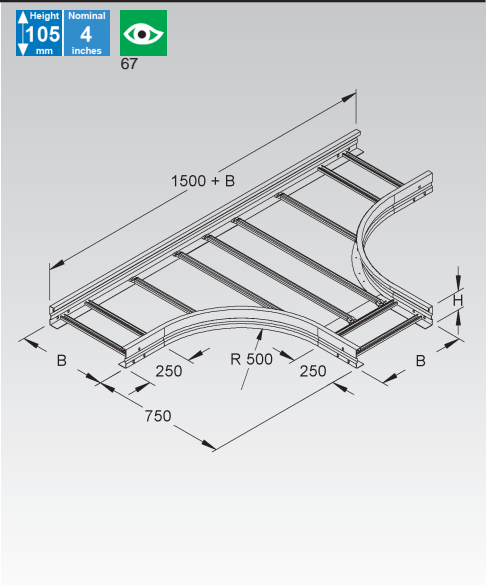

Pair of Protective End Caps

	model no.	height H		color	Weight per 100 pair kg	Pack/ Box Qty
		mm	Inch			
K10	SKWHM 105	105	4,1	yellow	11,12	10 sets

protective end cap for WSL 105... siderails

Suitable for: WSL 105... longspan cable ladder

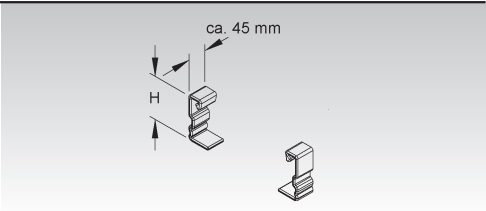

Long Span Cable Ladder

C-channel rungs with 16 mm slot width, standard spacing 300 mm

model no.	height H		width B		length A		thickness t mm	Weight per 100 m/ kg	Pack/ Box Qty
	mm	Inch	mm	Inch	mm	Inch			
S WSL 150.200	150	5,9	200	7,9	6000	236,2	1,5	651,54	6 m
S WSL 150.300	150	5,9	300	11,8	6000	236,2	1,5	637,00	6 m
S WSL 150.400	150	5,9	400	15,7	6000	236,2	1,5	660,00	6 m
S WSL 150.450	150	5,9	450	17,7	6000	236,2	1,5	719,63	6 m
S WSL 150.500	150	5,9	500	19,7	6000	236,2	1,5	684,00	6 m
S WSL 150.600	150	5,9	600	23,6	6000	236,2	1,5	707,00	6 m
S WSL 150.900	150	5,9	900	35,4	6000	236,2	1,5	1.030,34	6 m
F WSL 150.200 F	150	5,9	200	7,9	6000	236,2	1,5	716,69	6 m
F WSL 150.300 F	150	5,9	300	11,8	6000	236,2	1,5	746,65	6 m
F WSL 150.400 F	150	5,9	400	15,7	6000	236,2	1,5	776,62	6 m
F WSL 150.450 F	150	5,9	450	17,7	6000	236,2	1,5	791,60	6 m
F WSL 150.500 F	150	5,9	500	19,7	6000	236,2	1,5	804,66	6 m
F WSL 150.600 F	150	5,9	600	23,6	6000	236,2	1,5	834,61	6 m
F WSL 150.900 F	150	5,9	900	35,4	6000	236,2	1,5	1.133,37	6 m
E3 WSL 150.200 E3	150	5,9	200	7,9	6000	236,2	1,5	655,69	6 m
E3 WSL 150.300 E3	150	5,9	300	11,8	6000	236,2	1,5	683,10	6 m
E3 WSL 150.400 E3	150	5,9	400	15,7	6000	236,2	1,5	710,51	6 m
E3 WSL 150.500 E3	150	5,9	500	19,7	6000	236,2	1,5	736,17	6 m
E3 WSL 150.600 E3	150	5,9	600	23,6	6000	236,2	1,5	763,57	6 m

Also available in 3 meter length.

Load Chart: q = uniformly distributed load (tested according to DIN EN IEC 61537 standard)

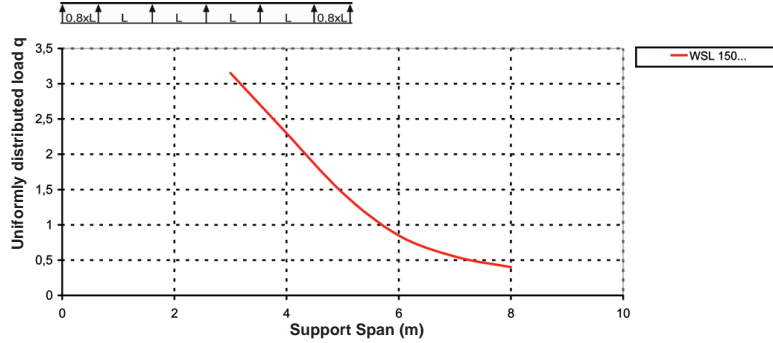

Specified load ratings are independent of splice plate location.

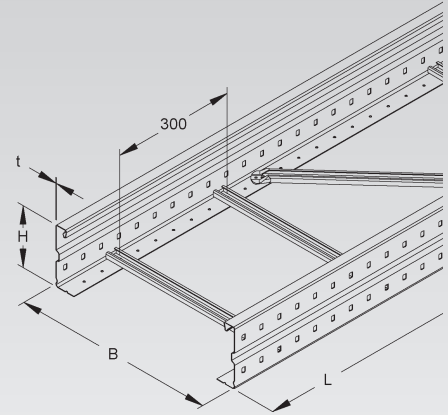
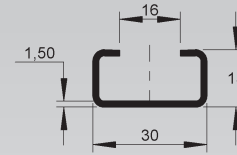
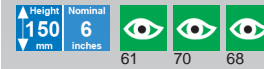

LONG SPAN CABLE LADDER

Long Span Cable Ladder

C-channel rungs with 16 mm slot width, standard spacing 300 mm

	model no.	height H		width B		length A		thickness t	Weight per 100 m	Pack/Box Qty
		mm	Inch	mm	Inch	mm	Inch			
S	WSLM 150.200	150	5,9	200	7,9	6000	236,2	2	845,80	6 m
S	WSLM 150.300	150	5,9	300	11,8	6000	236,2	2	873,03	6 m
S	WSLM 150.400	150	5,9	400	15,7	6000	236,2	2	900,28	6 m
S	WSLM 150.450	150	5,9	450	17,7	6000	236,2	2	913,90	6 m
S	WSLM 150.500	150	5,9	500	19,7	6000	236,2	2	925,77	6 m
S	WSLM 150.600	150	5,9	600	23,6	6000	236,2	2	953,00	6 m
S	WSLM 150.900	150	5,9	900	35,4	6000	236,2	2	1.224,60	6 m
F	WSLM 150.200 F	150	5,9	200	7,9	6000	236,2	2	930,38	6 m
F	WSLM 150.300 F	150	5,9	300	11,8	6000	236,2	2	960,34	6 m
F	WSLM 150.400 F	150	5,9	400	15,7	6000	236,2	2	990,30	6 m
F	WSLM 150.450 F	150	5,9	450	17,7	6000	236,2	2	1.005,29	6 m
F	WSLM 150.500 F	150	5,9	500	19,7	6000	236,2	2	1.018,35	6 m
F	WSLM 150.600 F	150	5,9	600	23,6	6000	236,2	2	1.048,30	6 m
F	WSLM 150.900 F	150	5,9	900	35,4	6000	236,2	2	1.347,06	6 m

Also available in 3 meter length.

Load Chart: q = uniformly distributed load (tested according to DIN EN IEC 61537 standard)

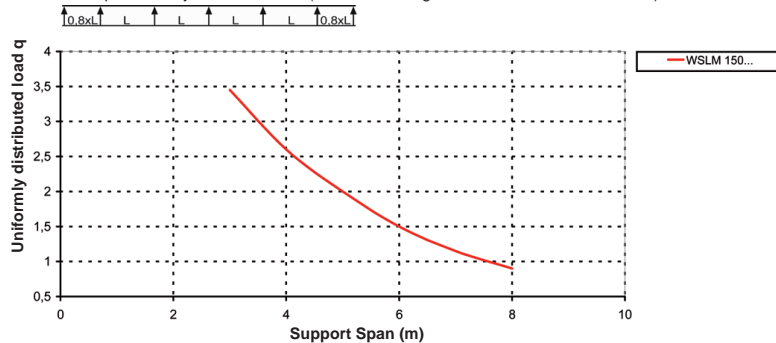

Specified load ratings are independent of splice plate location.

Height 150 mm
Nominal 6 inches
Eye icon
68

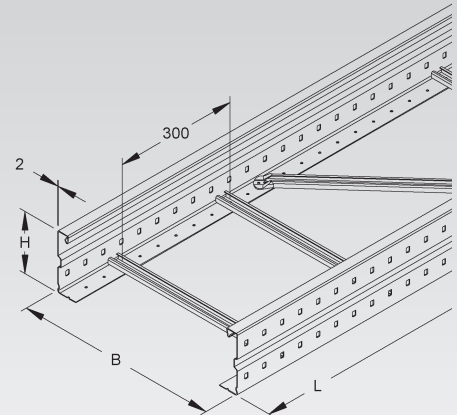
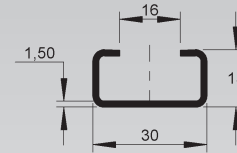

Splice Plate

	model no.	inside height H		width B		Weight per 100 pcs	Pack/Box Qty
		mm	Inch	mm	Inch		
S	WSV 150.500	151,5	6	500	19,7	180	10
F	WSV 150.500 F	151,5	6	500	19,7	202	10
E3	WSV 150.500 E3	151,5	6	500	19,7	185	10

form-locking straight splice plate for long span trays and ladders

2 pieces required per joint

UL classified splice plates ensure electrical continuity and proper bonding.

Height 150 mm
Nominal 6 inches
Eye icon
70

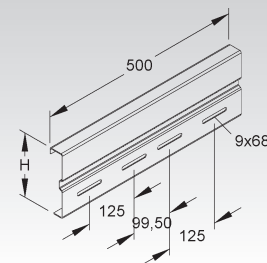

Adjustable Splice Plate

vertical

	model no.	inside height H		Weight per 100 pcs	Pack/Box Qty
		mm	Inch		
S	WSGV 150	151,5	6	151,95	1
F	WSGV 150 F	151,5	6	180,00	1
E3	WSGV 150 E3	151,5	6	152,42	1

2 pieces required per joint

UL classified splice plates ensure electrical continuity and proper bonding.

Height 150 mm
Nominal 6 inches
Eye icon
68

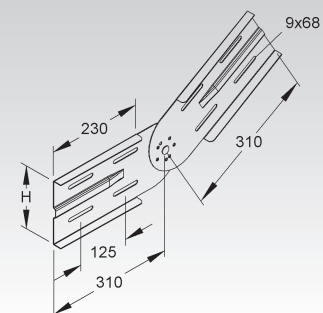

Adjustable Splice Plate

horizontal

	model no.	inside height H		width B		Weight per 100 pcs kg	Pack/Box Qty
		mm	Inch	mm	Inch		
S	WSWV 150	151,5	6	500	19,7	128,75	10
F	WSWV 150 F	151,5	6	500	19,7	140,49	10
E3	WSWV 150 E3	151,5	6	500	19,7	130,70	10

2 pieces required per joint

UL classified splice plates ensure electrical continuity and proper bonding.

Height
150 mm
Nominal
6 inches

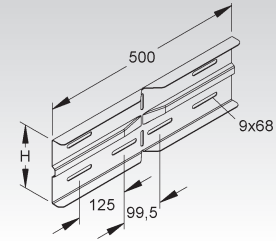

Barrier Strip

	model no.	height H		thickness t	Weight per 100 m kg	Pack/Box Qty
		mm	Inch			
S	RW 110	98	3,9	0,9	90,37	10 x 3 m
F	RW 110 F	98	3,9	0,9	99,30	10 x 3 m
E3	RW 110 E3	98	3,9	0,9	90,94	10 x 3 m

to separate wires and cables of different voltage levels or with different functions

Height
110 mm
Nominal
4 3/8 inches



61

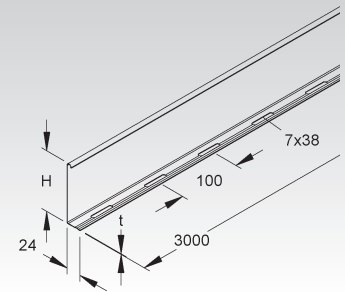

Splice Plate for Barrier Strip

	model no.	height H		length A		Weight per 100 pcs kg	Pack/Box Qty
		mm	Inch	mm	Inch		
E2	RTV 110 E2	97,5	3,8	80	3,1	2,5	20

for positive locking connections and proper bonding of barrier strips

Height
110 mm
Nominal
4 3/8 inches



61

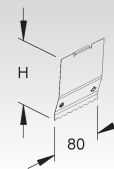

Mounting Clamp for Barrier Strip

	model no.	Weight per 100 pcs kg		Pack/Box Qty
		mm	Inch	
S	KLWC 16	2,50	50	
F	KLWC 16 F	2,69	50	
E3	KLWC 16 E3	2,96	50	



61

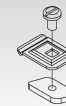

Horizontal Elbow Building Block

with integrated splices

	model no.	inside height H		Weight per 100 pcs kg	Pack/Box Qty
		mm	Inch		
S	WAER 150	151,5	6	431,90	1
F	WAER 150 F	151,5	6	473,90	1
E3	WAER 150 E3	151,5	6	433,11	1

for field manufacturing of longspan elbows and tees

Height
150 mm
Nominal
6 inches

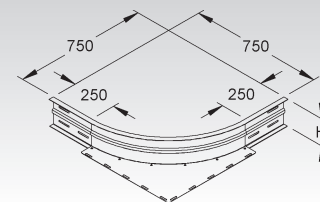

LONG SPAN CABLE LADDER

Horizontal Elbow 90°

with solid siderails but prepunched holes for splice plates

	model no.	height H		width B		Weight per 100 pcs kg	Pack/Box Qty
		mm	Inch	mm	Inch		
S	WSBR 150.200	150	5,9	200	7,9	981,84	1
S	WSBR 150.300	150	5,9	300	11,8	1.082,76	1
S	WSBR 150.400	150	5,9	400	15,7	1.183,70	1
S	WSBR 150.450	150	5,9	450	17,7	1.234,02	1
S	WSBR 150.500	150	5,9	500	19,7	1.284,62	1
S	WSBR 150.600	150	5,9	600	23,6	1.385,55	1
S	WSBR 150.900	150	5,9	900	35,4	2.100,26	1
F	WSBR 150.200 F	150	5,9	200	7,9	1.080,03	1
F	WSBR 150.300 F	150	5,9	300	11,8	1.191,04	1
F	WSBR 150.400 F	150	5,9	400	15,7	1.302,07	1
F	WSBR 150.450 F	150	5,9	450	17,7	1.357,42	1
F	WSBR 150.500 F	150	5,9	500	19,7	1.413,09	1
F	WSBR 150.600 F	150	5,9	600	23,6	1.524,11	1
F	WSBR 150.900 F	150	5,9	900	35,4	2.310,29	1
E3	WSBR 150.200 E3	150	5,9	200	7,9	960,40	1
E3	WSBR 150.300 E3	150	5,9	300	11,8	1.053,40	1
E3	WSBR 150.400 E3	150	5,9	400	15,7	1.175,90	1
E3	WSBR 150.500 E3	150	5,9	500	19,7	1.272,50	1
E3	WSBR 150.600 E3	150	5,9	600	23,6	1.372,80	1

WSV 150.500 splice plates have to be ordered separately.

Height 150 mm
Nominal 6 inches

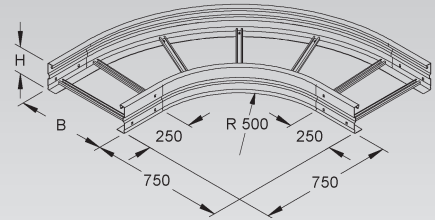

Extension Horizontal Tee

with integrated splices

	model no.	inside height H		inside dimension (B)		Weight per 100 pcs kg	Pack/Box Qty
		mm	Inch	mm	Inch		
S	WSTAR 150.200	151,5	6	205	8,1	1.024,57	1
S	WSTAR 150.300	151,5	6	305	12	1.061,22	1
S	WSTAR 150.400	151,5	6	405	15,9	1.098,84	1
S	WSTAR 150.450	151,5	6	455	17,9	1.117,74	1
S	WSTAR 150.500	151,5	6	505	19,9	1.138,20	1
S	WSTAR 150.600	151,5	6	605	23,8	1.170,55	1
S	WSTAR 150.900	151,5	6	905	35,6	1.420,21	1
F	WSTAR 150.200 F	151,5	6	205	8,1	1.124,63	1
F	WSTAR 150.300 F	151,5	6	305	12	1.164,94	1
F	WSTAR 150.400 F	151,5	6	405	15,9	1.206,33	1
F	WSTAR 150.450 F	151,5	6	455	17,9	1.227,12	1
F	WSTAR 150.500 F	151,5	6	505	19,9	1.249,62	1
F	WSTAR 150.600 F	151,5	6	605	23,8	1.285,20	1
F	WSTAR 150.900 F	151,5	6	905	35,6	1.559,83	1

for field manufacturing of horizontal tees and crosses

Height 150 mm
Nominal 6 inches

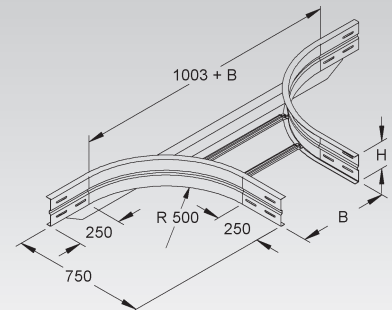

Horizontal Tee

with solid siderails but prepunched holes for splice plates

	model no.	height H		width B		Weight per 100 pcs kg	Pack/Box Qty
		mm	Inch	mm	Inch		
S	WSTR 150.200	150	5,9	200	7,9	1.548,78	1
S	WSTR 150.300	150	5,9	300	11,8	1.654,92	1
S	WSTR 150.400	150	5,9	400	15,7	1.818,67	1
S	WSTR 150.450	150	5,9	450	17,7	1.878,76	1
S	WSTR 150.500	150	5,9	500	19,7	2.014,90	1
S	WSTR 150.600	150	5,9	600	23,6	2.143,30	1
S	WSTR 150.900	150	5,9	900	35,4	3.472,80	1
F	WSTR 150.200 F	150	5,9	200	7,9	1.703,66	1
F	WSTR 150.300 F	150	5,9	300	11,8	1.820,41	1
F	WSTR 150.400 F	150	5,9	400	15,7	2.000,54	1
F	WSTR 150.450 F	150	5,9	450	17,7	2.066,63	1
F	WSTR 150.500 F	150	5,9	500	19,7	2.216,39	1
F	WSTR 150.600 F	150	5,9	600	23,6	2.357,63	1
F	WSTR 150.900 F	150	5,9	900	35,4	3.820,08	1
E3	WSTR 150.200 E3	150	5,9	200	7,9	1.534,80	1
E3	WSTR 150.300 E3	150	5,9	300	11,8	1.644,00	1
E3	WSTR 150.400 E3	150	5,9	400	15,7	1.807,60	1
E3	WSTR 150.500 E3	150	5,9	500	19,7	2.003,50	1
E3	WSTR 150.600 E3	150	5,9	600	23,6	2.131,80	1

WSV 150.500 splice plates have to be ordered separately.

Height
150 mm
Nominal
6 inches

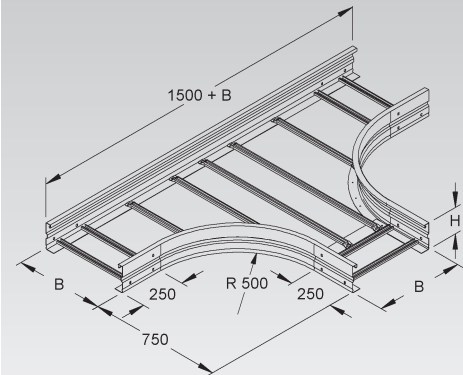

Reducer

	model no.	height H		width B		Weight per 100 pcs kg	Pack/Box Qty
		mm	Inch	mm	Inch		
★ S	WSRS 150.100 S	150	5,9	100	3,9	53,61	1
★ S	WSRS 150.150 S	150	5,9	150	5,9	62,20	1
★ S	WSRS 150.200 S	150	5,9	200	7,9	70,80	1
★ S	WSRS 150.300 S	150	5,9	300	11,8	87,99	1

can be used as a reducer for longspan cable trays and ladders

Height
150 mm
Nominal
6 inches

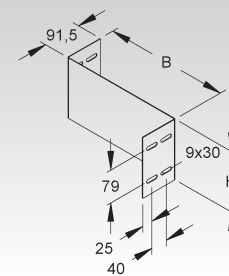

Endplate

	model no.	height H		width B		Weight per 100 pcs kg	Pack/Box Qty
		mm	Inch	mm	Inch		
★ S	WSAS 150.200 S	150	5,9	200	7,9	70	1
★ S	WSAS 150.300 S	150	5,9	300	11,8	90	1
★ S	WSAS 150.400 S	150	5,9	400	15,7	100	1
★ S	WSAS 150.450 S	150	5,9	450	17,7	108	1
★ S	WSAS 150.500 S	150	5,9	500	19,7	117	1
★ S	WSAS 150.600 S	150	5,9	600	23,6	123	1
★ S	WSAS 150.900 S	150	5,9	900	35,4	192	1

can be used as blind end or as reducer for longspan cable trays and ladders

Height
150 mm
Nominal
6 inches

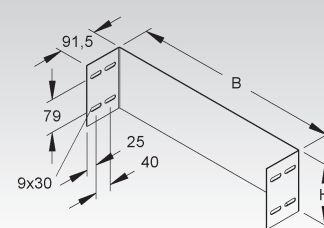

LONG SPAN CABLE LADDER

Ladder Drop Out

	model no.	width B		Weight per 100 pcs kg	Pack/Box Qty
		mm	Inch		
S	WLAB 200	190	7,5	36,81	1
S	WLAB 300	290	11,4	59,54	1
S	WLAB 400	390	15,4	82,27	1
S	WLAB 500	490	19,3	137,75	1
S	WLAB 600	590	23,2	167,73	1
F	WLAB 200 F	190	7,5	40,37	1
F	WLAB 300 F	290	11,4	65,37	1
F	WLAB 400 F	390	15,4	90,37	1
F	WLAB 500 F	490	19,3	151,40	1
F	WLAB 600 F	590	23,2	184,38	1
E3	WLAB 200 E3	190	7,5	60,00	1
E3	WLAB 300 E3	290	11,4	90,00	1
E3	WLAB 400 E3	390	15,4	120,00	1
E3	WLAB 500 E3	490	19,3	150,00	1
E3	WLAB 600 E3	590	23,2	180,00	1

with rounded edges to protect cables at the drop out

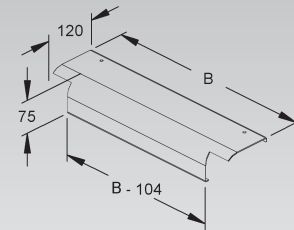

Mounting Clamp for Long Span Ladders

	model no.	Weight per 100 pcs kg	Pack/Box Qty
F	WSTB 2	12,19	50
E3	WSTB 2 E3	11,96	50

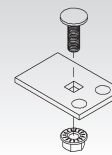

Two Hole Corner Angle

	model no.	thickness t mm	Weight per 100 pcs kg	Pack/Box Qty
F	WWU 150/8	5	19,11	50
E3	WWU 150/8 E3	4	14,87	50

for floor-, ceiling- or wall-mount

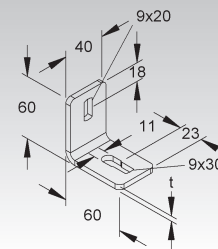

Three Hole Corner Angle

	model no.	thickness t mm	Weight per 100 pcs kg	Pack/Box Qty
F	WWA 100	5	24,98	50
E3	WWA 100 E3	4	19,75	50

for floor-, ceiling- or wall-mount

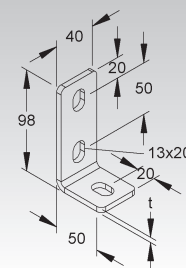

Cover for Long Span Cable Trays/Ladders

with turnbolt locks

	model no.	width B		Weight per 100 m kg	Pack/ Box Qty
		mm	Inch		
S	WDV 200	204	8	151,26	2 x 3 m
S	WDV 300	304	12	251,52	2 x 3 m
S	WDV 400	404	15,9	357,60	2 x 3 m
S	WDV 450	454	17,9	396,78	2 x 3 m
S	WDV 500	504	19,8	436,10	2 x 3 m
S	WDV 600	604	23,8	514,60	2 x 3 m
S	WDV 900	904	35,6	1.123,33	2 x 3 m
F	WDV 200 F	204	8	166,39	2 x 3 m
F	WDV 300 F	304	12	276,67	2 x 3 m
F	WDV 400 F	404	15,9	393,36	2 x 3 m
F	WDV 450 F	454	17,9	436,45	2 x 3 m
F	WDV 500 F	504	19,8	479,71	2 x 3 m
F	WDV 600 F	604	23,8	566,06	2 x 3 m
F	WDV 900 F	904	35,6	1.235,66	2 x 3 m
E3	WDV 200 E3	204	8	162,89	2 x 3 m
E3	WDV 300 E3	304	12	253,86	2 x 3 m
E3	WDV 400 E3	404	15,9	360,62	2 x 3 m
E3	WDV 500 E3	504	19,8	439,62	2 x 3 m
E3	WDV 600 E3	604	23,8	518,62	2 x 3 m

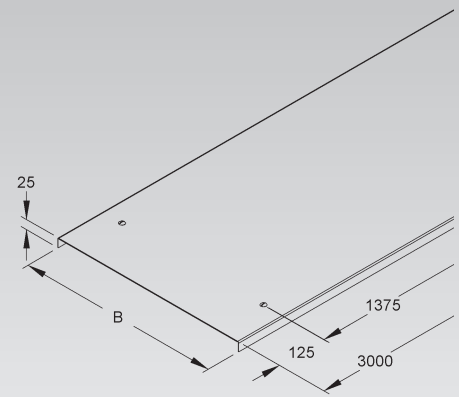

Suitable for: WRL..., WRLM... and WRU... longspan cable trays as well as WSL... and WSLM... longspan cable ladders

For outdoor service covers need to be secured against windloads using heavy duty cover clamps or steel cable ties.

Cover for 90° Horizontal Elbow

with turnbolt locks

	model no.	inside dimension (B)		Weight per 100 pcs/ kg	Pack/ Box Qty
		mm	Inch		
S	WBRDV 200	204	8	245,01	1
S	WBRDV 300	304	12	376,38	1
S	WBRDV 400	404	15,9	520,08	1
S	WBRDV 450	454	17,9	596,55	1
S	WBRDV 500	504	19,8	676,11	1
S	WBRDV 600	604	23,8	844,47	1
S	WBRDV 900	904	35,6	1.423,52	1
F	WBRDV 200 F	204	8	269,43	1
F	WBRDV 300 F	304	12	413,94	1
F	WBRDV 400 F	404	15,9	572,00	1
F	WBRDV 450 F	454	17,9	656,21	1
F	WBRDV 500 F	504	19,8	743,64	1
F	WBRDV 600 F	604	23,8	928,83	1
F	WBRDV 900 F	904	35,6	1.565,87	1
E3	WBRDV 200 E3	204	8	248,81	1
E3	WBRDV 300 E3	304	12	381,01	1
E3	WBRDV 400 E3	404	15,9	525,63	1
E3	WBRDV 500 E3	504	19,8	682,65	1
E3	WBRDV 600 E3	604	23,8	852,08	1
E3	WBRDV 900 E3	904	35,6	1.434,74	1

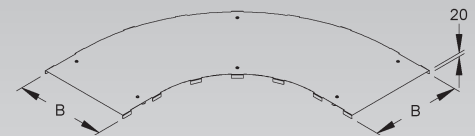

Suitable for: WRBR... and WSBR... horizontal 90° longspan elbows

For outdoor service covers need to be secured against windloads using heavy duty cover clamps or steel cable ties.

LONG SPAN CABLE LADDER ACCESSORIES

Cover for Horizontal Extension Tee

with turnbolt locks

model no.	inside dimension (B) mm Inch	Weight per 100 pcs/ kg	Pack/Box Qty
S WTARDV 200	212,5 8,4	258,73	1
S WTARDV 300	312,5 12,3	319,88	1
S WTARDV 400	412,5 16,2	381,03	1
S WTARDV 450	462,5 18,2	411,61	1
S WTARDV 500	512,5 20,2	442,18	1
S WTARDV 600	612,5 24,1	503,34	1
S WTARDV 900	912,5 35,9	686,79	1
F WTARDV 200 F	212,5 8,4	296,17	1
F WTARDV 300 F	312,5 12,3	363,44	1
F WTARDV 400 F	412,5 16,2	430,71	1
F WTARDV 450 F	462,5 18,2	454,42	1
F WTARDV 500 F	512,5 20,2	497,97	1
F WTARDV 600 F	612,5 24,1	565,24	1
F WTARDV 900 F	912,5 35,9	757,12	1
E3 WTARDV 200 E3	212,5 8,4	261,85	1
E3 WTARDV 300 E3	312,5 12,3	323,39	1
E3 WTARDV 400 E3	412,5 16,2	384,93	1
E3 WTARDV 500 E3	512,5 20,2	446,47	1
E3 WTARDV 600 E3	612,5 24,1	508,01	1
E3 WTARDV 900 E3	912,5 35,9	692,58	1

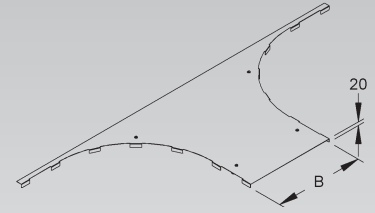

Suitable for: WRTAR... and WSTAR... longspan extension tee fittings

For outdoor service covers need to be secured against windloads using heavy duty cover clamps or steel cable ties.

Cover for Horizontal Tee

with turnbolt locks

model no.	inside dimension (B) mm Inch	Weight per 100 pcs kg	Pack/Box Qty
S WTRDV 200	204 8	514,69	1
S WTRDV 300	304 12	732,24	1
S WTRDV 400	404 15,9	965,50	1
S WTRDV 450	454 17,9	1.088,01	1
S WTRDV 500	504 19,8	1.214,45	1
S WTRDV 600	604 23,8	1.479,10	1
F WTRDV 200 F	204 8	566,08	1
F WTRDV 300 F	304 12	805,38	1
F WTRDV 400 F	404 15,9	1.061,93	1
F WTRDV 450 F	454 17,9	1.196,81	1
F WTRDV 500 F	504 19,8	1.335,81	1
F WTRDV 600 F	604 23,8	1.626,92	1
E3 WTRDV 200 E3	204 8	520,20	1
E3 WTRDV 300 E3	304 12	739,14	1
E3 WTRDV 400 E3	404 15,9	973,88	1
E3 WTRDV 500 E3	504 19,8	1.224,42	1
E3 WTRDV 600 E3	604 23,8	1.490,75	1

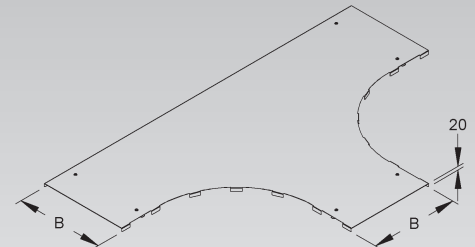

Suitable for: WRTR... and WSTR... longspan tee fittings

For outdoor service covers need to be secured against windloads using heavy duty cover clamps or steel cable ties.

Turnbolt Lock

model no.	Weight per 100 pcs kg	Pack/Box Qty
S WDRS 20	2,25	50
F WDRS 20 F	2,64	50
E3 WDRS 20 E3	2,53	50

for field installation

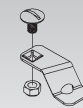

NOTES

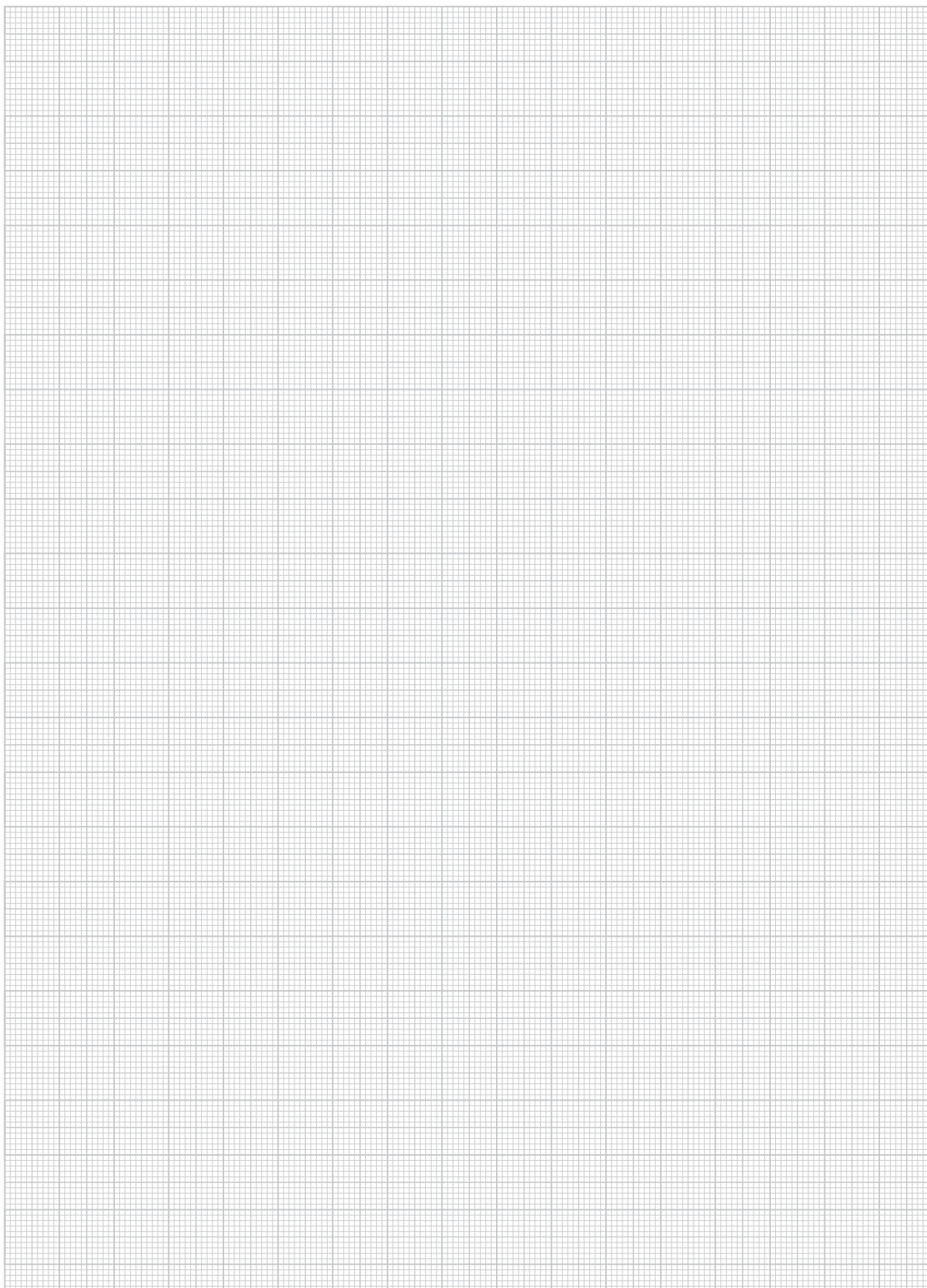
A large rectangular area filled with a fine grid of light gray lines, intended for writing notes. The grid consists of small squares, approximately 10x10 units per centimeter.

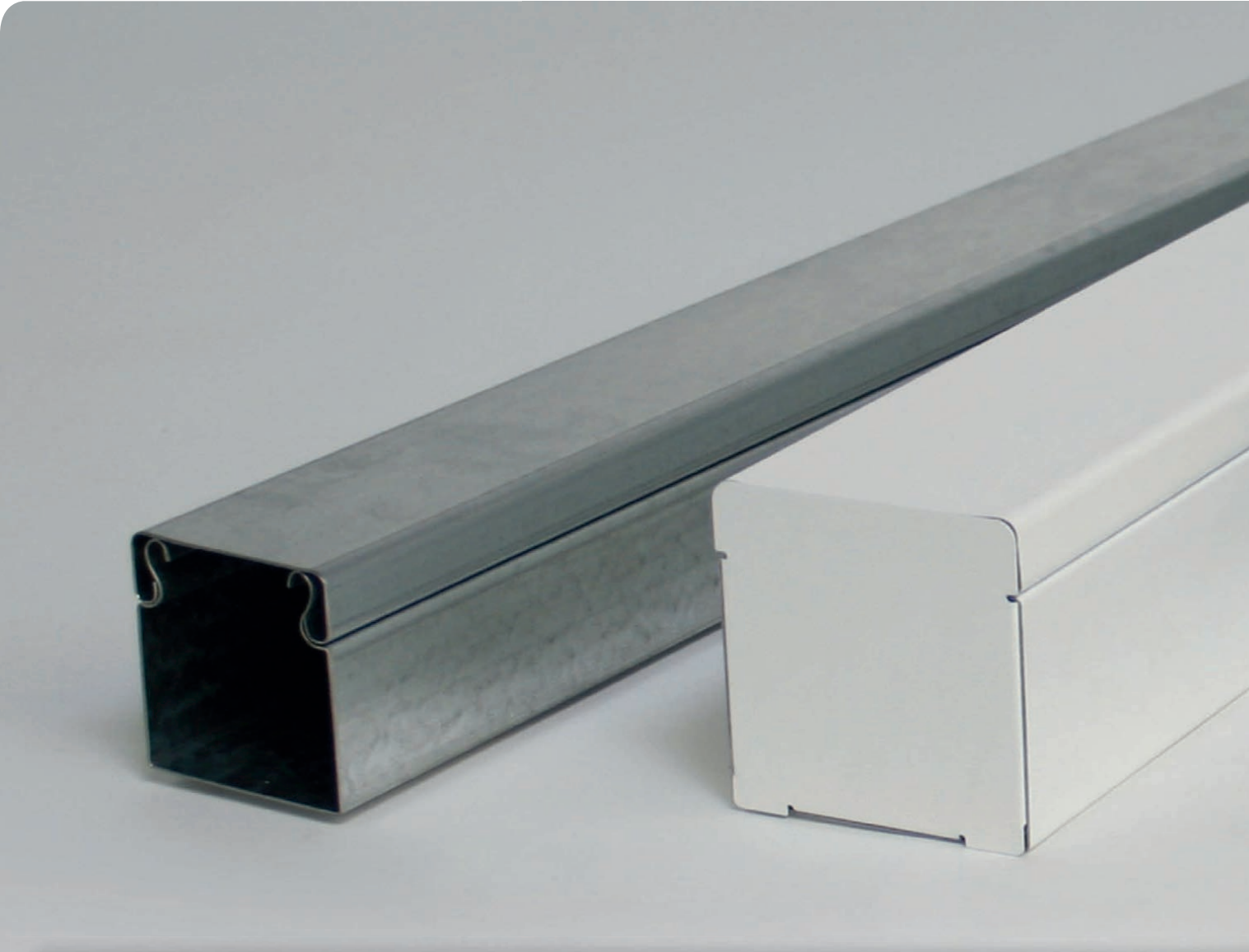

CHANNEL CABLE TRAY

- Channel Cable tray
- Fittings
- Accessoires



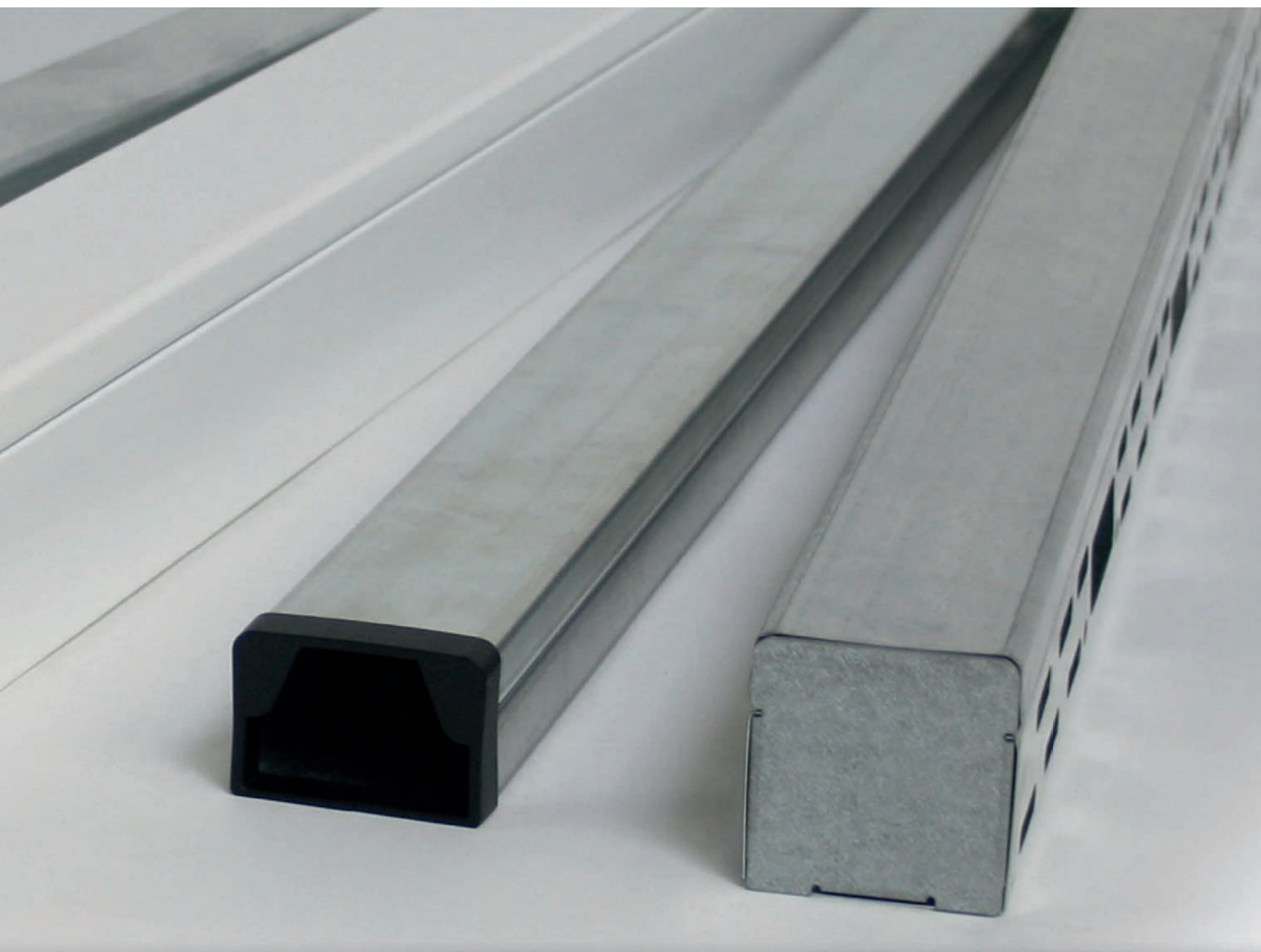

Niedax channel cable trays are designed for routing low voltage power circuits, data network and control cables in commercial, institutional and industrial applications. The system consists of a base section with a snap-on cover, dividers and a wide range of fittings. It's easy to install, expand and reconfigure. Direct wall mount is permitted. Various finishes are available.

CHANNEL CABLE TRAY

Available Side Rail Heights

↑ Height 16 mm	↓ Nominal 5/8 inches	↑ Height 26 mm	↓ Nominal 1 inches	↑ Height 40 mm	↓ Nominal 1 5/8 inches	↑ Height 60 mm	↓ Nominal 2 3/8 inches	↑ Height 80 mm	↓ Nominal 3 inches	↑ Height 100 mm	↓ Nominal 4 inches
----------------------	----------------------------	----------------------	--------------------------	----------------------	------------------------------	----------------------	------------------------------	----------------------	--------------------------	-----------------------	--------------------------

SYSTEM			
	Channel Cable Tray	LLK...	Page 309
	Channel Cable Tray	LLK...	Page 310
	Channel Cable Tray	LUK...	Page 311
ZUBEHÖR	Splice Plate	LST...	Page 309/311
	End-Cap	LED...	Page 309/316
	End-Protection Ring	LER...	Page 309/316
	Mounting Plate for Barrier Strip	LZTP...	Page 311
	Barrier Strip	TPS...	Page 311
	Outside Elbow 45°	LUAB...	Page 312
	Inside Elbow 45°	LUIB...	Page 312
	Elbow 45°	LUWB...	Page 312
	Outside Elbow 90°	LUAC...	Page 313
	Outside Wide Radius Elbow (2x45°)	LUAD...	Page 313
	Inside Elbow 90°	LUIC...	Page 313
	Wide Radius Elbow (2x45°)	LUID...	Page 314
	Elbow 90°	LUWC...	Page 314
	Wide Radius Elbow (2x45°)	LUWD...	Page 314
	Wide Radius Tee	LUTC...	Page 315
	Horizontal Tee	LUT..	Page 315
	Cable Retainer Clamp	LHS...	Page 316
	End-Protection Ring	LES...	Page 316



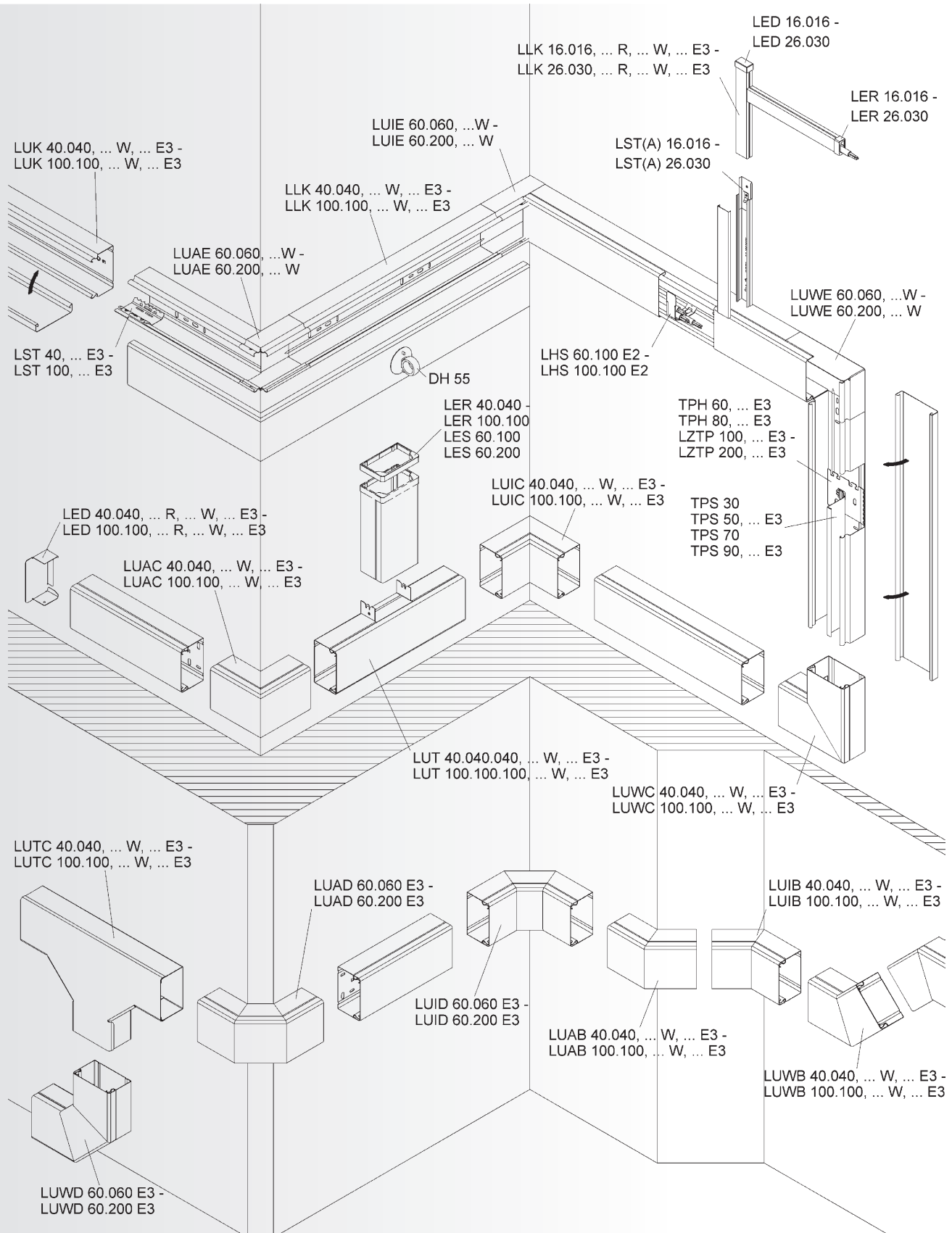

Channel Cable Tray Specifications:

➔ A. CABLE TRAY DESIGN

1. Channel Cable Tray shall be made of straight sections, fittings and accessories as defined in the latest NEMA standards per NEMA VE-1. Standard cable trays shall be UL classified as equipment grounding conductors.

➔ B. MATERIAL

1. **Pre-galvanized steel.** The structural quality of the steel shall meet the minimum yield and tensile strength of the ASTM standards (ASTM A 653) with G 90 coating thickness. All cable trays to be labeled for material identification purposes.

2. **Powder coated pre-galvanized steel.** All trays to be made from pre-galvanized steel and powder coated after fabrication. All trays to be labeled for material identification.

3. **Stainless steel.** All trays are to be constructed of AISI type 304 or type 316 stainless steel. All trays to be labeled for material identification.

➔ C. TRAY TYPES

1. **Solid channel cable tray.** Trays are to be fabricated from continuous roll-formed structural quality steel. Sides are to be solid as well as bottom for maximum cable enclosure and support.

2. **Solid channel cable tray with mounting holes.** Trays are to be fabricated from continuous roll-formed structural quality steel. Sides are to be solid, bottom has predrilled mounting holes for easy installation.

➔ D. TRAY SIZE

1. **Height:** Trays shall have an overall height of 1", 1.5", 2.3", 3.1", and 4" (26, 40, 60, 80 and 100 mm). Loading depth is the same as the overall height, as there are no rungs to reduce the fill of the tray.

2. **Width:** Widths shall be 1", 1.5", 2.3", 3.1", 4", 6", and 8" (30, 40, 60, 80, 100, 150 and 200 mm).

3. **Length:** Length shall be a nominal 6.6' or 2 meters.

➔ E. ACCESSORIES

1. **Covers.** Covers to protect tray cable shall be supplied automatically with every piece of channel tray and every fitting.

2. **Splice plates.** Splice plates have to be ordered separately for all straight sections and fittings.

3. **Other accessories** shall be furnished as required to protect, support, and install a cable tray system. Fittings shall be made of the same material as the cable tray whenever possible. Fittings can be of factory construction or may also be of a type that allows field constructed fittings.

➔ F. LOADING CAPABILITIES

1. Channel cable tray shall meet the load/span class designation in accordance with NEMA VE 1 and CSA C22.2 No 126.1. Cable tray shall also meet load/span designation in accordance with IEC 61537.

➔ G. DESIGN AND MANUFACTURE

1. Cable tray design shall be manufactured by The Niedax Group, series LLK and LUK.



Channel Cable Tray

cover included

model no.		height H		width B		RAL colour	Weight per 100 m kg	Pack/Box Qty
		mm	Inch	mm	Inch			
S	LLK 16.016	16	0,6	16	0,6	—	30,00	48 x 2 m
S	LLK 16.030	16	0,6	30	1,2	—	42,50	30 x 2 m
S	LLK 26.030	26	1	30	1,2	—	52,50	18 x 2 m
E3	LLK 16.016 E3	16	0,6	16	0,6	—	15,00	48 x 2 m
E3	LLK 16.030 E3	16	0,6	30	1,2	—	18,00	30 x 2 m
E3	LLK 26.030 E3	26	1	30	1,2	—	50,48	18 x 2 m

Please use LST... snapin splice plates for proper mechanical and electrical connections.
Splice plates have to be ordered separately.

Height 16 mm	Nominal 5/8 inches	Height 26 mm	Nominal 1 inches	
--------------------	--------------------------	--------------------	------------------------	--

71

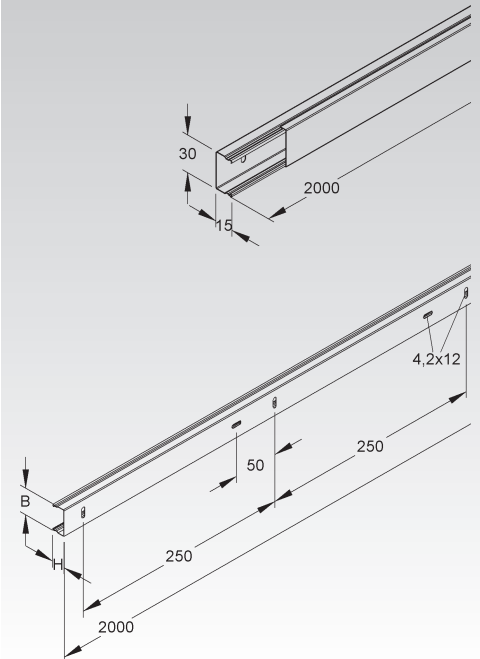

Splice Plate

model no.		length A	Weight per 100 pcs kg	Pack/Box Qty	
		mm	Inch		
MS	LST 16.016	74	2,9	5,0	20
MS	LST 16.030	74	2,9	1,0	20
MS	LST 26.030	74	2,9	1,2	20

mechanical splice and electrical connector for raceways

1 piece required per joint

Height 16 mm	Nominal 5/8 inches	Height 26 mm	Nominal 1 inches
--------------------	--------------------------	--------------------	------------------------

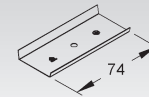

End-Cap

model no.		height H	width B	color	Weight per 100 pcs kg	Pack/Box Qty
		mm	Inch			
K04	LED 16.016	16	0,6	black	0,10	20
K04	LED 16.030	16	0,6	black	0,18	20
K04	LED 26.030	26	1	black	0,23	20

Height 16 mm	Nominal 5/8 inches	Height 26 mm	Nominal 1 inches	
--------------------	--------------------------	--------------------	------------------------	--

71

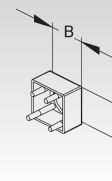

End-Protection Ring

model no.		height H	width B	RAL colour	Weight per 100 pcs kg	Pack/Box Qty
		mm	Inch			
K04	LER 16.016	16	0,6	7021	0,15	20
K04	LER 16.030	16	0,6	7021	0,21	20
K04	LER 26.030	26	1	7021	0,27	20

contains no silicone

End caps LER... can be attached to the channel cable tray after installation.

Height 16 mm	Nominal 5/8 inches	Height 26 mm	Nominal 1 inches	
--------------------	--------------------------	--------------------	------------------------	--

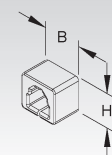

CHANNEL CABLE TRAY

Channel Cable Tray

with perforated bottom, cover included

	model no.	height H		width B		RAL colour	Weight per 100 m kg	Pack/Box Qty
		mm	Inch	mm	Inch			
S	LLK 40.040	40	1,6	40	1,6	—	94,16	12 x 2 m
S	LLK 40.060	40	1,6	60	2,4	—	147,00	6 x 2 m
S	LLK 60.060	60	2,4	60	2,4	—	174,74	6 x 2 m
E3	LLK 40.040 E3	40	1,6	40	1,6	—	94,76	12 x 2 m
E3	LLK 40.060 E3	40	1,6	60	2,4	—	147,00	6 x 2 m
E3	LLK 60.060 E3	60	2,4	60	2,4	—	184,26	6 x 2 m

Hole pattern may vary based on width of tray.

Please use LST... snapin splice plates for proper mechanical and electrical connections.

Height 40 mm	Nominal 1 5/8 inches	Height 60 mm	Nominal 2 3/8 inches	
--------------------	----------------------------	--------------------	----------------------------	--

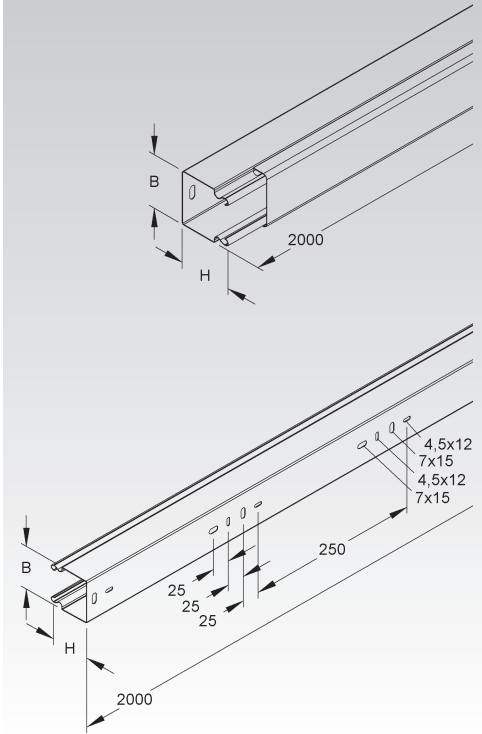

Channel Cable Tray

with perforated bottom, cover included

	model no.	height H		width B		distance between drilling holes A	RAL colour	Weight per 100 m kg	Pack/Box Qty
		mm	Inch	mm	Inch				
S	LLK 60.100	60	2,4	100	3,9	50	—	235,73	4 x 2 m
S	LLK 60.150	60	2,4	150	5,9	100	—	332,00	2 x 2 m
S	LLK 60.200	60	2,4	200	7,9	150	—	421,68	2 x 2 m
S	LLK 80.080	80	3,1	80	3,1	30	—	233,68	4 x 2 m
S	LLK 100.100	100	3,9	100	3,9	50	—	318,00	4 x 2 m
E3	LLK 60.100 E3	60	2,4	100	3,9	50	—	249,27	4 x 2 m
E3	LLK 60.200 E3	60	2,4	200	7,9	150	—	403,00	2 x 2 m
E3	LLK 80.080 E3	79	3,1	80	3,1	30	—	249,90	4 x 2 m
E3	LLK 100.100 E3	100	3,9	100	3,9	50	—	318,00	4 x 2 m

Hole pattern may vary based on width of tray.

Please use LST... snapin splice plates for proper mechanical and electrical connections.

Height 60 mm	Nominal 2 3/8 inches	Height 80 mm	Nominal 3 inches	Height 100 mm	Nominal 4 inches	
--------------------	----------------------------	--------------------	------------------------	---------------------	------------------------	--

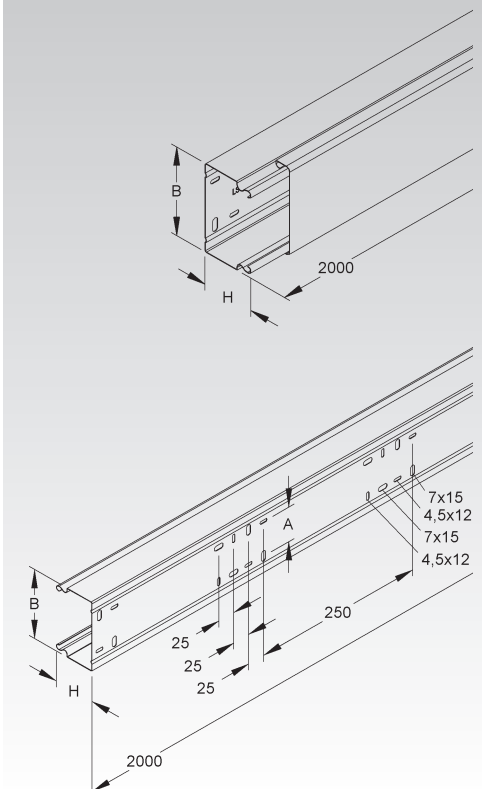

Channel Cable Tray

solid bottom, including cover

	model no.	height H		width B		RAL colour	Weight per 100 m kg	Pack/Box Qty
		mm	Inch	mm	Inch			
S	LUK 40.040	40	1,6	40	1,6	—	80	12 x 2 m
S	LUK 40.060	40	1,6	60	2,4	—	147	6 x 2 m
S	LUK 60.060	60	2,4	60	2,4	—	171	6 x 2 m
S	LUK 60.100	60	2,4	100	3,9	—	218	4 x 2 m
S	LUK 60.150	60	2,4	150	5,9	—	332	2 x 2 m
S	LUK 60.200	60	2,4	200	7,9	—	403	2 x 2 m
S	LUK 80.080	79	3,1	80	3,1	—	262	4 x 2 m
S	LUK 100.100	100	3,9	100	3,9	—	321	4 x 2 m
E3	LUK 40.040 E3	40	1,6	40	1,6	—	80	12 x 2 m
E3	LUK 40.060 E3	40	1,6	60	2,4	—	147	6 x 2 m
E3	LUK 60.060 E3	60	2,4	60	2,4	—	171	6 x 2 m
E3	LUK 60.100 E3	60	2,4	100	3,9	—	218	4 x 2 m
E3	LUK 60.200 E3	60	2,4	200	7,9	—	403	2 x 2 m
E3	LUK 80.080 E3	79	3,1	80	3,1	—	262	4 x 2 m

Please use LST... snapin splice plates for proper mechanical and electrical connections.

Height 40 mm	Nominal 1 5/8 inches	Height 60 mm	Nominal 2 3/8 inches	Height 80 mm	Nominal 3 inches	Height 100 mm	Nominal 4 inches	
-----------------	-------------------------	-----------------	-------------------------	-----------------	---------------------	------------------	---------------------	--

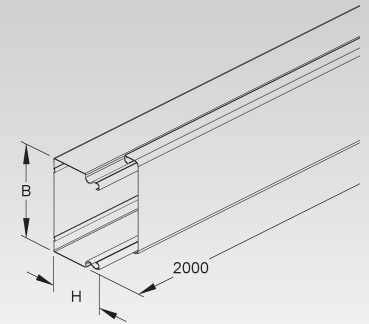

Splice Plate

with flat contact pin (6,3 mm) for protective grounding

	model no.	height H		Weight per 100 pcs kg	Pack/Box Qty
		mm	Inch		
S	LST 40	40	1,6	1,77	20
S	LST 60	60	2,4	2,71	20
S	LST 80	80	3,1	3,70	20
S	LST 100	100	3,9	4,63	20
E3	LST 40 E3	40	1,6	1,88	20
E3	LST 60 E3	60	2,4	2,88	20
E3	LST 80 E3	80	3,1	3,85	20
E3	LST 100 E3	100	3,9	4,90	20

mechanical splice and electrical connector for Channel Cable Tray

2 pieces required per joint

Height 40 mm	Nominal 1 5/8 inches	Height 60 mm	Nominal 2 3/8 inches	Height 80 mm	Nominal 3 inches	Height 100 mm	Nominal 4 inches	
-----------------	-------------------------	-----------------	-------------------------	-----------------	---------------------	------------------	---------------------	--

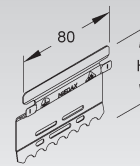

Mounting Plate for Barrier Strip

with strain relief

	model no.	depth T	Weight per 100 pcs kg	Pack/Box Qty
		mm		
S	LZTP 100	99	5,48	20
S	LZTP 150	149	8,29	20
S	LZTP 200	199	11,10	20
E3	LZTP 100 E3	99	6,13	20
E3	LZTP 200 E3	199	12,41	20

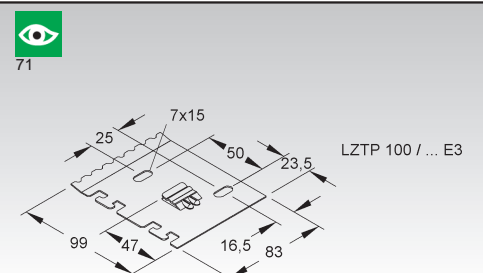

Barrier Strip

	model no.	height H		depth T	Weight per 100 m kg	Pack/Box Qty
		mm	Inch			
S	TPS 30	11	0,4	30	36,47	10 x 2 m
S	TPS 50	11	0,4	50	48,31	10 x 2 m
S	TPS 70	11	0,4	70	59,97	10 x 2 m
S	TPS 90	11	0,4	90	71,72	10 x 2 m
E3	TPS 50 E3	11	0,4	50	51,73	10 x 2 m
E3	TPS 90 E3	11	0,4	90	76,86	10 x 2 m

to separate wires and cables of different voltage levels or with different functions

Suitable for: Channel Cable Tray

Height 30 mm	Nominal 1 1/8 inches	Height 50 mm	Nominal 2 inches	Height 70 mm	Nominal 2 3/4 inches	Height 90 mm	Nominal 3 1/2 inches	
-----------------	-------------------------	-----------------	---------------------	-----------------	-------------------------	-----------------	-------------------------	--

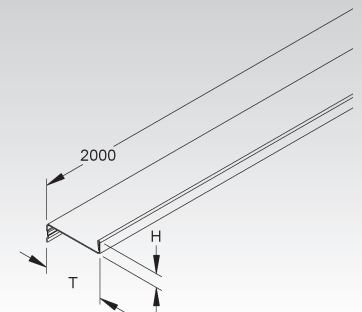

CHANNEL CABLE TRAY

Outside Elbow 45°

cover included

	model no.	height H		width B		RAL colour	Weight per 100 pcs kg	Pack/Box Qty
		mm	Inch	mm	Inch			
S	LUAB 40.040	40	1,6	40	1,6	—	17,92	8
S	LUAB 40.060	40	1,6	60	2,4	—	25,26	8
S	LUAB 60.060	60	2,4	60	2,4	—	35,12	8
S	LUAB 60.100	60	2,4	100	3,9	—	47,03	8
S	LUAB 60.150	60	2,4	150	5,9	—	69,80	4
S	LUAB 60.200	60	2,4	200	7,9	—	84,55	4
S	LUAB 80.080	80	3,1	80	3,1	—	48,59	4
S	LUAB 100.100	100	3,9	100	3,9	—	66,21	4
E3	LUAB 40.040 E3	40	1,6	40	1,6	—	19,00	1
E3	LUAB 40.060 E3	40	1,6	60	2,4	—	39,00	1
E3	LUAB 60.060 E3	60	2,4	60	2,4	—	42,00	1
E3	LUAB 60.100 E3	60	2,4	100	3,9	—	50,15	1
E3	LUAB 60.200 E3	60	2,4	200	7,9	—	72,00	1
E3	LUAB 80.080 E3	80	3,1	80	3,1	—	46,00	1
E3	LUAB 100.100 E3	100	3,9	100	3,9	—	57,00	1

Please use LST... snapin splice plates for proper mechanical and electrical connections.
Splice plates have to be ordered separately.

Height 40 mm	Nominal 1 5/8 inches	Height 60 mm	Nominal 2 3/8 inches	Height 80 mm	Nominal 3 inches	Height 100 mm	Nominal 4 inches
--------------------	----------------------------	--------------------	----------------------------	--------------------	------------------------	---------------------	------------------------

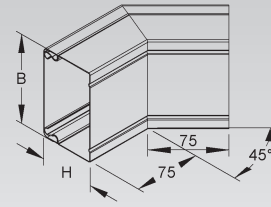

Inside Elbow 45°

cover included

	model no.	height H		width B		RAL colour	Weight per 100 pcs kg	Pack/Box Qty
		mm	Inch	mm	Inch			
S	LUIB 40.040	40	1,6	40	1,6	—	16,60	8
S	LUIB 40.060	40	1,6	60	2,4	—	23,37	8
S	LUIB 60.060	60	2,4	60	2,4	—	36,00	8
S	LUIB 60.100	60	2,4	100	3,9	—	43,29	8
S	LUIB 60.150	60	2,4	150	5,9	—	65,67	4
S	LUIB 60.200	60	2,4	200	7,9	—	79,24	4
S	LUIB 80.080	80	3,1	80	3,1	—	46,00	8
S	LUIB 100.100	100	3,9	100	3,9	—	65,78	4
E3	LUIB 40.040 E3	40	1,6	40	1,6	—	14,00	1
E3	LUIB 40.060 E3	40	1,6	60	2,4	—	34,00	1
E3	LUIB 60.060 E3	60	2,4	60	2,4	—	36,00	1
E3	LUIB 60.100 E3	60	2,4	100	3,9	—	46,10	1
E3	LUIB 60.200 E3	60	2,4	200	7,9	—	71,00	1
E3	LUIB 80.080 E3	80	3,1	80	3,1	—	45,00	1
E3	LUIB 100.100 E3	100	3,9	100	3,9	—	56,00	1

Please use LST... snapin splice plates for proper mechanical and electrical connections.
Splice plates have to be ordered separately.

Height 40 mm	Nominal 1 5/8 inches	Height 60 mm	Nominal 2 3/8 inches	Height 80 mm	Nominal 3 inches	Height 100 mm	Nominal 4 inches
--------------------	----------------------------	--------------------	----------------------------	--------------------	------------------------	---------------------	------------------------

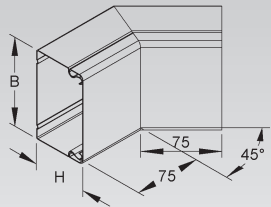

Elbow 45°

cover included

	model no.	height H		width B		RAL colour	Weight per 100 pcs kg	Pack/Box Qty
		mm	Inch	mm	Inch			
S	LUWB 40.040	40	1,6	40	1,6	—	16,82	8
S	LUWB 40.060	40	1,6	60	2,4	—	25,27	8
S	LUWB 60.060	60	2,4	60	2,4	—	34,09	8
S	LUWB 60.100	60	2,4	100	3,9	—	49,96	8
S	LUWB 60.150	60	2,4	150	5,9	—	81,92	4
S	LUWB 60.200	60	2,4	200	7,9	—	107,45	4
S	LUWB 80.080	80	3,1	80	3,1	—	47,97	8
S	LUWB 100.100	100	3,9	100	3,9	—	67,91	4
E3	LUWB 40.040 E3	40	1,6	40	1,6	—	14,00	1
E3	LUWB 40.060 E3	40	1,6	60	2,4	—	36,00	1
E3	LUWB 60.060 E3	60	2,4	60	2,4	—	38,00	1
E3	LUWB 60.100 E3	60	2,4	100	3,9	—	52,22	1
E3	LUWB 60.200 E3	60	2,4	200	7,9	—	85,00	1
E3	LUWB 80.080 E3	80	3,1	80	3,1	—	45,00	1
E3	LUWB 100.100 E3	100	3,9	100	3,9	—	56,00	1

Please use LST... snapin splice plates for proper mechanical and electrical connections.
Splice plates have to be ordered separately.

Height 40 mm	Nominal 1 5/8 inches	Height 60 mm	Nominal 2 3/8 inches	Height 80 mm	Nominal 3 inches	Height 100 mm	Nominal 4 inches
--------------------	----------------------------	--------------------	----------------------------	--------------------	------------------------	---------------------	------------------------

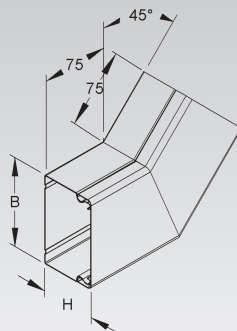

Outside Elbow 90°

cover included

	model no.	height H		width B		RAL colour	Weight per 100 pcs kg	Pack/ Box Qty
		mm	Inch	mm	Inch			
S	LUAC 40.040	40	1,6	40	1,6	—	22,34	8
S	LUAC 40.060	40	1,6	60	2,4	—	31,16	8
S	LUAC 60.060	60	2,4	60	2,4	—	43,50	8
S	LUAC 60.100	60	2,4	100	3,9	—	59,95	8
S	LUAC 60.150	60	2,4	150	5,9	—	87,95	4
S	LUAC 60.200	60	2,4	200	7,9	—	107,10	4
S	LUAC 80.080	80	3,1	80	3,1	—	62,11	8
S	LUAC 100.100	100	3,9	100	3,9	—	97,38	4
E3	LUAC 40.040 E3	40	1,6	40	1,6	—	16,00	1
E3	LUAC 40.060 E3	40	1,6	60	2,4	—	50,00	1
E3	LUAC 60.060 E3	60	2,4	60	2,4	—	53,00	1
E3	LUAC 60.100 E3	60	2,4	100	3,9	—	60,00	1
E3	LUAC 60.200 E3	60	2,4	200	7,9	—	90,00	1
E3	LUAC 80.080 E3	80	3,1	80	3,1	—	65,00	1
E3	LUAC 100.100 E3	100	3,9	100	3,9	—	98,00	1

Please use LST... snapin splice plates for proper mechanical and electrical connections.
Splice plates have to be ordered separately.

Height 40 mm	Nominal 1 5/8 inches	Height 60 mm	Nominal 2 3/8 inches	Height 80 mm	Nominal 3 inches	Height 100 mm	Nominal 4 inches
--------------------	----------------------------	--------------------	----------------------------	--------------------	------------------------	---------------------	------------------------

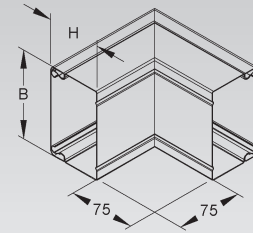

Outside Wide Radius Elbow (2x45°)

cover included

	model no.	height H		width B		Weight per 100 pcs kg	Pack/ Box Qty
		mm	Inch	mm	Inch		
S	LUAD 60.060	60	2,4	60	2,4	63	1
S	LUAD 60.100	60	2,4	100	3,9	72	1
S	LUAD 60.200	60	2,4	200	7,9	108	1
E3	LUAD 60.060 E3	60	2,4	60	2,4	63	1
E3	LUAD 60.100 E3	60	2,4	100	3,9	72	1
E3	LUAD 60.200 E3	60	2,4	200	7,9	108	1
E3	LUAD 100.100 E3	100	3,9	100	3,9	145	1

Please use LST... snapin splice plates for proper mechanical and electrical connections.
Splice plates have to be ordered separately.

Height 60 mm	Nominal 2 3/8 inches	Height 100 mm	Nominal 4 inches
--------------------	----------------------------	---------------------	------------------------

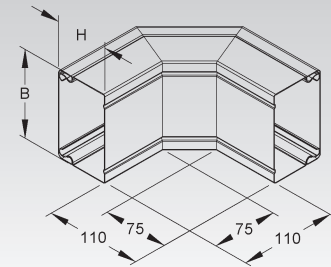

Inside Elbow 90°

cover included

	model no.	height H		width B		RAL colour	Weight per 100 pcs kg	Pack/ Box Qty
		mm	Inch	mm	Inch			
S	LUIC 40.040	40	1,6	40	1,6	—	19,32	8
S	LUIC 40.060	40	1,6	60	2,4	—	26,45	8
S	LUIC 60.060	60	2,4	60	2,4	—	37,74	8
S	LUIC 60.100	60	2,4	100	3,9	—	53,96	8
S	LUIC 60.150	60	2,4	150	5,9	—	80,33	4
S	LUIC 60.200	60	2,4	200	7,9	—	97,36	4
S	LUIC 80.080	80	3,1	80	3,1	—	56,15	8
S	LUIC 100.100	100	3,9	100	3,9	—	89,42	4
E3	LUIC 40.040 E3	40	1,6	40	1,6	—	19,00	1
E3	LUIC 40.060 E3	40	1,6	60	2,4	—	43,00	1
E3	LUIC 60.060 E3	60	2,4	60	2,4	—	45,00	1
E3	LUIC 60.100 E3	60	2,4	100	3,9	—	58,00	1
E3	LUIC 60.200 E3	60	2,4	200	7,9	—	89,00	1
E3	LUIC 80.080 E3	80	3,1	80	3,1	—	58,00	1
E3	LUIC 100.100 E3	100	3,9	100	3,9	—	74,00	1

Please use LST... snapin splice plates for proper mechanical and electrical connections.
Splice plates have to be ordered separately.

Height 40 mm	Nominal 1 5/8 inches	Height 60 mm	Nominal 2 3/8 inches	Height 80 mm	Nominal 3 inches	Height 100 mm	Nominal 4 inches
--------------------	----------------------------	--------------------	----------------------------	--------------------	------------------------	---------------------	------------------------

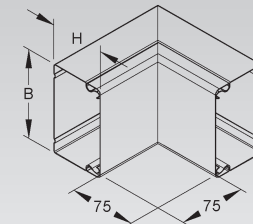

CHANNEL CABLE TRAY

Wide Radius Elbow (2x45°)

cover included

	model no.	height H		width B		Weight per 100 pcs/kg	Pack/Box Qty
		mm	Inch	mm	Inch		
S	LUID 60.060	60	2,4	60	2,4	46,33	1
S	LUID 60.100	60	2,4	100	3,9	64,28	1
S	LUID 60.200	60	2,4	200	7,9	107,00	1
E3	LUID 60.060 E3	60	2,4	60	2,4	54,00	1
E3	LUID 60.100 E3	60	2,4	100	3,9	68,55	1
E3	LUID 60.200 E3	60	2,4	200	7,9	107,00	1
E3	LUID 100.100 E3	100	3,9	100	3,9	105,00	1

Please use LST... snapin Splice plates have to be ordered separately

▲ Height	60	Nominal	2 3/8	▲ Height	100	Nominal	4
▼	mm		inches	▼	mm		inches

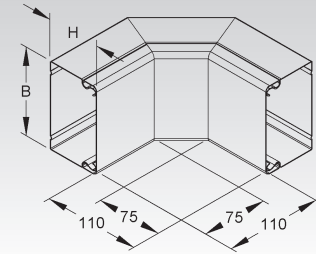

Elbow 90°

cover included

	model no.	height H		width B		RAL colour	Weight per 100 pcs/kg	Pack/Box Qty
		mm	Inch	mm	Inch			
S	LUWC 40.040	40	1,6	40	1,6	—	19,24	8
S	LUWC 40.060	40	1,6	60	2,4	—	30,15	8
S	LUWC 60.060	60	2,4	60	2,4	—	39,91	8
S	LUWC 60.100	60	2,4	100	3,9	—	64,25	8
S	LUWC 60.150	60	2,4	150	5,9	—	112,68	4
S	LUWC 60.200	60	2,4	200	7,9	—	156,83	4
S	LUWC 80.080	80	3,1	80	3,1	—	60,48	8
S	LUWC 100.100	100	3,9	100	3,9	—	88,03	4
E3	LUWC 40.040 E3	40	1,6	40	1,6	—	16,00	1
E3	LUWC 40.060 E3	40	1,6	60	2,4	—	45,00	1
E3	LUWC 60.060 E3	60	2,4	60	2,4	—	47,00	1
E3	LUWC 60.100 E3	60	2,4	100	3,9	—	61,00	1
E3	LUWC 60.200 E3	60	2,4	200	7,9	—	107,00	1
E3	LUWC 80.080 E3	80	3,1	80	3,1	—	62,50	1
E3	LUWC 100.100 E3	100	3,9	100	3,9	—	83,00	1

Please use LST... snapin splice plates for proper mechanical and electrical connections.

Splice plates have to be ordered separately.

▲ Height	40	Nominal	1 5/8	▲ Height	60	Nominal	2 3/8	▲ Height	80	Nominal	3	▲ Height	100	Nominal	4
▼	mm		inches	▼	mm		inches	▼	mm		inches	▼	mm		inches

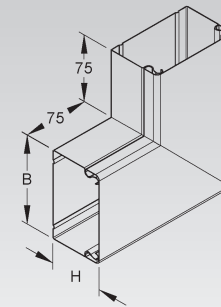

Wide Radius Elbow (2x45°)

	model no.	height H		width B		Weight per 100 pcs/kg	Pack/Box Qty
		mm	Inch	mm	Inch		
S	LUWD 60.060	60	2,4	60	2,4	51,52	1
S	LUWD 60.100	60	2,4	100	3,9	76,29	1
S	LUWD 60.200	60	2,4	200	7,9	128,00	1
E3	LUWD 60.060 E3	60	2,4	60	2,4	57,00	1
E3	LUWD 60.100 E3	60	2,4	100	3,9	74,00	1
E3	LUWD 60.200 E3	60	2,4	200	7,9	128,00	1
E3	LUWD 100.100 E3	100	3,9	100	3,9	98,00	1

Please use LST... snapin splice plates for proper mechanical and electrical connections.

Splice plates have to be ordered separately.

▲ Height	60	Nominal	2 3/8	▲ Height	100	Nominal	4
▼	mm		inches	▼	mm		inches

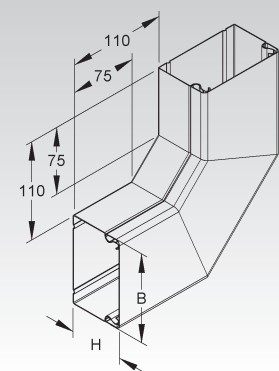

Wide Radius Tee

cover included

	model no.	height H		width B		RAL colour	Weight per 100 pcs kg	Pack/Box Qty
		mm	Inch	mm	Inch			
S	LUTC 40.060	40	1,6	60	2,4	—	92,36	2
S	LUTC 60.060	60	2,4	60	2,4	—	106,50	2
S	LUTC 60.100	60	2,4	100	3,9	—	145,29	2
S	LUTC 60.150	60	2,4	150	5,9	—	200,84	1
S	LUTC 60.200	60	2,4	200	7,9	—	264,25	1
S	LUTC 80.080	80	3,1	80	3,1	—	206,97	1
S	LUTC 100.100	100	3,9	100	3,9	—	252,37	1
E3	LUTC 40.060 E3	40	1,6	60	2,4	—	92,92	1
E3	LUTC 60.060 E3	60	2,4	60	2,4	—	107,15	1
E3	LUTC 60.100 E3	60	2,4	100	3,9	—	146,19	1
E3	LUTC 80.080 E3	80	3,1	80	3,1	—	208,26	1
E3	LUTC 100.100 E3	100	3,9	100	3,9	—	253,95	1

Size of run and tap tray must be identical.

The dimensions put in parentheses are for models LUTC 80.080 & 100.100 only.

Please use LST... snapin splice plates for proper mechanical and electrical connections.

Splice plates have to be ordered separately.

Height	Nominal	Height	Nominal	Height	Nominal	Height	Nominal
40	1 5/8	60	2 3/8	80	3	100	4
mm	inches	mm	inches	mm	inches	mm	inches

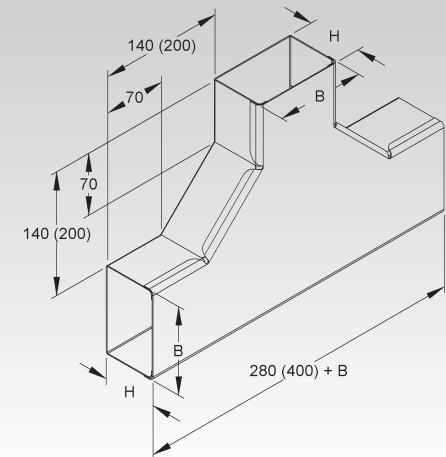

Horizontal Tee

cover included

	model no.	height H		width B		width of exit A	RAL colour	Weight per 100 pcs kg	Pack/Box Qty
		mm	Inch	mm	Inch				
S	LUT 40.040.040	40	1,6	40	1,6	40	—	33,52	2
S	LUT 40.060.040	40	1,6	60	2,4	40	—	46,65	2
S	LUT 60.060.060	60	2,4	60	2,4	60	—	61,49	2
S	LUT 60.100.060	60	2,4	100	3,9	60	—	82,85	2
S	LUT 60.100.100	60	2,4	100	3,9	100	—	81,12	2
S	LUT 60.150.060	60	2,4	150	5,9	60	—	123,13	2
S	LUT 60.150.100	60	2,4	150	5,9	100	—	121,07	2
S	LUT 60.150.150	60	2,4	150	5,9	150	—	118,49	2
S	LUT 60.200.060	60	2,4	200	7,9	60	—	148,71	2
S	LUT 60.200.100	60	2,4	200	7,9	100	—	146,64	2
S	LUT 60.200.150	60	2,4	200	7,9	150	—	144,07	2
S	LUT 60.200.200	60	2,4	200	7,9	200	—	141,49	2
S	LUT 80.080.080	80	3,1	80	3,1	80	—	82,14	2
S	LUT 100.100.100	100	3,9	100	3,9	100	—	110,11	2
E3	LUT 40.040.040 E3	40	1,6	40	1,6	40	—	33,82	2
E3	LUT 40.060.040 E3	40	1,6	60	2,4	40	—	47,03	2
E3	LUT 60.060.060 E3	60	2,4	60	2,4	60	—	64,66	2
E3	LUT 60.100.060 E3	60	2,4	100	3,9	60	—	88,90	2
E3	LUT 60.100.100 E3	60	2,4	100	3,9	100	—	87,04	2
E3	LUT 60.200.060 E3	60	2,4	200	7,9	60	—	133,90	2
E3	LUT 60.200.100 E3	60	2,4	200	7,9	100	—	132,04	2
E3	LUT 60.200.200 E3	60	2,4	200	7,9	200	—	127,40	2
E3	LUT 80.080.080 E3	80	3,1	80	3,1	80	—	88,13	2
E3	LUT 100.100.100 E3	100	3,9	100	3,9	100	—	104,95	2

H x B = height and width of the tee fitting

A = width of the 90° tee exit

Please use LST... snapin splice plates for proper mechanical and electrical connections.

Splice plates have to be ordered separately.

Height	Nominal	Height	Nominal	Height	Nominal	Height	Nominal
40	1 5/8	60	2 3/8	80	3	100	4
mm	inches	mm	inches	mm	inches	mm	inches

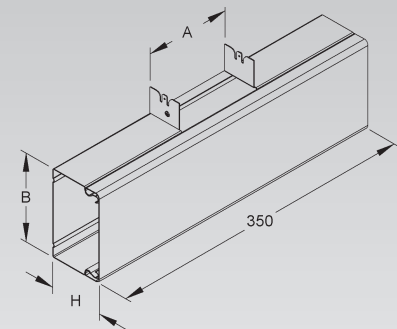

CHANNEL CABLE TRAY

End-Cap

model no.	height H		width B		RAL colour	Weight per 100 pcs kg	Pack/Box Qty
	mm	Inch	mm	Inch			
S LED 40.040	40	1,6	40	1,6	—	1,70	6
S LED 40.060	40	1,6	60	2,4	—	2,50	6
S LED 60.060	60	2,4	60	2,4	—	3,88	6
S LED 60.100	60	2,4	100	3,9	—	5,62	6
S LED 60.150	60	2,4	150	5,9	—	7,81	6
S LED 60.200	60	2,4	200	7,9	—	9,99	6
S LED 80.080	80	3,1	80	3,1	—	6,32	6
S LED 100.100	100	3,9	100	3,9	—	9,40	6
E3 LED 40.040 E3	40	1,6	40	1,6	—	1,94	6
E3 LED 40.060 E3	40	1,6	60	2,4	—	2,50	6
E3 LED 60.060 E3	60	2,4	60	2,4	—	4,15	6
E3 LED 60.100 E3	60	2,4	100	3,9	—	6,03	6
E3 LED 60.200 E3	60	2,4	200	7,9	—	10,71	6
E3 LED 80.080 E3	80	3,1	80	3,1	—	6,79	6
E3 LED 100.100 E3	100	3,9	100	3,9	—	10,08	6

▲ Height 40 mm	▼ Nominal 1 5/8 inches	▲ Height 60 mm	▼ Nominal 2 3/8 inches	▲ Height 80 mm	▼ Nominal 3 inches	▲ Height 100 mm	▼ Nominal 4 inches	
----------------------	------------------------------	----------------------	------------------------------	----------------------	--------------------------	-----------------------	--------------------------	--

71

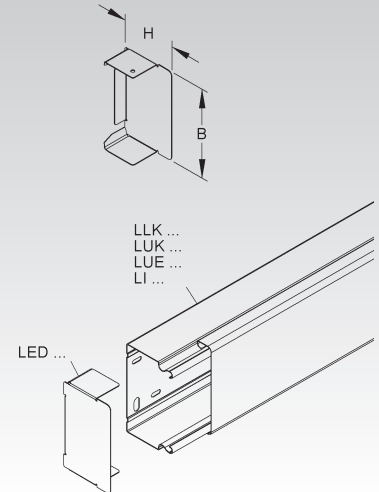

Cable Retainer Clamp

model no.	height H		width B		Weight per 100 pcs kg	Pack/Box Qty
	mm	Inch	mm	Inch		
E2 LHS 60.100 E2	60	2,4	55	2,2	2,03	20
E2 LHS 60.150 E2	60	2,4	105	4,1	2,99	20
E2 LHS 60.200 E2	60	2,4	155	6,1	3,95	20
E2 LHS 80.080 E2	80	3,1	35	1,4	2,40	20
E2 LHS 100.100 E2	100	3,9	55	2,2	2,47	20

▲ Height 60 mm	▼ Nominal 2 3/8 inches	▲ Height 80 mm	▼ Nominal 3 inches	▲ Height 100 mm	▼ Nominal 4 inches	
----------------------	------------------------------	----------------------	--------------------------	-----------------------	--------------------------	--

71

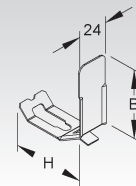

End-Protection Ring

model no.	height H		width B		RAL colour	Weight per 100 pcs kg	Pack/Box Qty
	mm	Inch	mm	Inch			
K04 LER 40.040	40	1,6	40	1,6	7021	0,33	10
K04 LER 40.060	40	1,6	60	2,4	7021	0,40	10
K04 LER 60.060	60	2,4	60	2,4	7021	0,49	10
K04 LER 60.100	60	2,4	100	3,9	7021	0,65	10
K04 LER 80.080	80	3,1	80	3,1	7021	1,23	10
K04 LER 100.100	100	3,9	100	3,9	7021	1,54	10

contains no silicone

End caps LER... can be attached to the channel cable tray after installation.

	▲ Height 40 mm	▼ Nominal 1 5/8 inches	▲ Height 60 mm	▼ Nominal 2 3/8 inches	▲ Height 80 mm	▼ Nominal 3 inches	▲ Height 100 mm	▼ Nominal 4 inches
--	----------------------	------------------------------	----------------------	------------------------------	----------------------	--------------------------	-----------------------	--------------------------

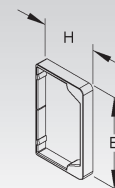

End-Protection Ring

model no.	height H		width B		color	Weight per 100 pcs kg	Pack/Box Qty
	mm	Inch	mm	Inch			
K10 LES 60.150	60	2,4	150	5,9	black	4,71	10
K10 LES 60.200	60	2,4	200	7,9	black	5,85	10

▲ Height 60 mm	▼ Nominal 2 3/8 inches
----------------------	------------------------------

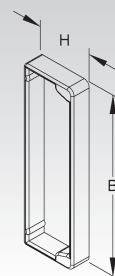

Conversion table of dimensions



1 inch = 25.4 millimeters (mm)

1 millimeter (mm) = 0.039 inch

Material Thickness

mm	0.6	0.75	0.8	0.9	1.0	1.5	2.0	2.5	3.0	3.5	4.0	4.5	5.0	6.0	7.0	8.0
inch	0.02	0.03	0.03	0.04	0.04	0.06	0.08	0.10	0.12	0.14	0.16	0.18	0.20	0.24	0.28	0.31

Product Length

mm	30	40	50	70	80	85	90	100	120	130	150	200	250	300	350	400
inch	1.18	1.57	1.97	2.76	3.15	3.35	3.54	3.94	4.72	5.12	5.91	7.87	9.84	11.81	13.78	15.75
mm	450	500	550	600	700	800	900	1000	1100	1200	1300	1400	1500	1600	1700	1800
inch	17.72	19.69	21.65	23.62	27.56	31.50	35.43	39.37	43.31	47.24	51.18	55.12	59.06	62.99	66.93	70.87
mm	1900	2000	3000	4500	6000											
inch	74.80	78.74	118.11	177.17	236.22											

Product Width

mm	40	50	60	70	75	90	100	120	150	200	250	300	400	500	550	600
inch	1.57	1.97	2.36	2.76	2.95	3.54	3.94	4.72	5.91	7.87	9.84	11.81	15.75	19.69	21.65	23.62
mm	700	800	900	1000	1100	1200										
inch	27.56	31.50	35.43	39.37	43.31	47.24										

Product Height

mm	10	15	20	25	30	35	40	50	60	85	100	105	110	150	200
inch	0.39	0.59	0.79	0.98	1.18	1.38	1.57	1.97	2.36	3.35	3.94	4.13	4.33	5.91	7.87

1 pound (lbs) = 0.453 kilogram (kg)

1 kilogram (kg) = 2.204 pounds (lbs)

Product Weight

kg	10	20	30	40	45	50	55	60	65	70	75	80	85	90	95	100
lbs	22.05	44.09	66.14	88.18	99.21	110.23	121.25	132.28	143.30	154.32	165.35	176.37	187.39	198.42	209.44	220.46
kg	105	110	115	120	125	130	135	140	150	160	170	180	190	200	210	220
lbs	231.49	242.50	253.53	264.55	275.58	286.60	297.62	308.65	330.69	352.74	374.79	396.83	418.88	440.92	462.97	485.02



USA

Niedax Inc.
2970 Charter Street
Columbus, OH 43228

Tel: +1 614 921 8469

sales@niedaxusa.com
www.niedaxusa.com

Canada

Niedax Canada
Bureau 216 du 3221
Autoroute 440 Ouest
Laval, Québec, H7P 5P2

Tel: +1 514 709 1603

fmichel@niedax.ca

Headquarters

Niedax GmbH & Co. KG
Asbacher Straße 141
D-53545 Linz/Germany

Tel: +49 2644 56060

export@niedax.de
www.niedax.de

Mexico

Niedax de Mexico S.A. de C.V.
Calle San Bernardo 9A,
Colonia Sanctorum Cuautlancingo
Puebla, Mexico C.P. 72730

Tel: +52 222 485 0586

salesmex@niedax.com
www.niedaxmex.com

